

FEATURES

- Universal Input Voltage Range of 120VAC \pm 16% or 230VAC \pm 16%
- Constant LED Current Controller
- Adjusted Constant Current Operation
- Low Quiescent Current
- Simplifies Circuit and System Designs
- PWM Dimming Control
- External N-channel MOSFET for High Current Application
- Temperature Compensated Constant Current
- Programmable Over Temperature Protection
- Programmable Over Current Protection
- Programmable LED Short Protection
- SOP10 Package

APPLICATIONS

- High Power LED Driver
- Lighting Applications
- T5 or T8 tube
- Low Cost solution
- Constant Current Sink

GENERAL DESCRIPTION

The EC4213 is a constant N-channel MOSFET current linear LED controller for replace discrete solutions in AC/DC power application (up to 270VAC). The controller can drive an output power of \pm 10% variation from a universal input voltage range of 120VAC \pm 16%, or 230VAC \pm 16% for different LED strings. The solution eliminates the need of individual components by combining them into a single package, which results in a significant reduction of both system cost and board space. The controller is capable of a dimming input for adjustable LED brightness control by Pulse Width Modulation (PWM). The EC4213 can protect the external N-channel MOSFET against over temperature and over current. Internal thermal foldback function regulates LED driving current automatically for temperature management of the LEDs or the N-channel MOSFET during high power operation or high ambient temperature conditions by an external NTC resistor. These features provide maximum system protection for the demanding lighting applications. The EC4213 is available in a space saving SOP10 package, and the operating temperature is from -40°C to $+125^{\circ}\text{C}$.

TYPICAL APPLICATION CIRCUIT

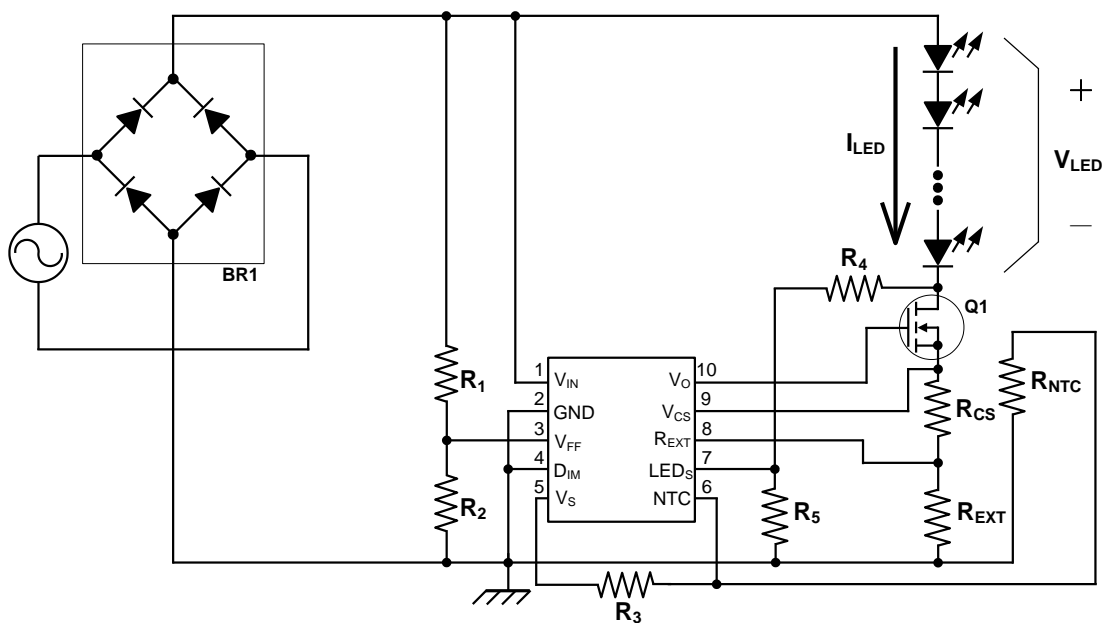

Fig. 1 Simplified Application Circuit



Constant Current N-Channel MOSFET Linear LED Controller

EC4213

ABSOLUTE MAXIMUM RATINGS

V _{IN} Supply Voltage.....	550V
V _{FF} , D _{IM} , V _S , NTC, LED _S , R _{EXT} , V _{CS} , V _O Operation Voltage.....	6V
Operating Temperature.....	-40°C to +125°C
Storage Temperature.....	-55°C to +150°C
Maximum Die Temperature.....	+150°C
Lead Temperature.....	+260°C
ESD HBM Voltage HV Pin.....	1.2kV
ESD HBM Voltage LV Pin.....	3.5kV
ESD MM Voltage.....	350V

PIN CONFIGURATION

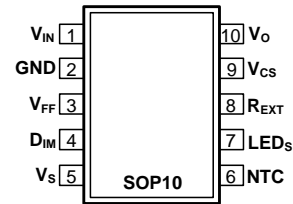

Note:

Absolute Maximum Ratings are those values beyond which damage to the device may occur. Functional operation under these conditions is not implied. Continuous operation of the device at the absolute rating level may affect device reliability.

ELECTRICAL CHARACTERISTICS

T_A = 25°C unless otherwise specified

PARAMETER		CONDITIONS	MIN	TYP	MAX	UNIT
Electrical Characteristic						
V _{IN}	Operation Voltage		25		500	V
I _{LED}	Current Regulation (Note 1)	V _{IN} =25Vdc, R _{EXT} =6Ω	95	100	105	mA
		V _{IN} =25Vdc, R _{EXT} =2Ω	285	300	315	mA
I _Q	Quiescent Current (Note 2)	V _{IN} =20Vdc, R _{EXT} =Open		300		μA
V _{REF}	Reference Voltage			0.6		V
V _S	External Reference Voltage			1.21		V
V _{DIM-H}	D _{IM} PIN High Threshold	V _{DIM} Rising	1.4			V
V _{DIM-L}	D _{IM} PIN Low Threshold	V _{DIM} Falling			0.4	V
Thermal Characteristic						
ΔV _{REF(T)}	V _{REF} Temperature Coefficient	T _A =-40°C ~125°C		0.01		%/°C
T _A	Operating Temperature		-40		125	°C
P _D	Total Power Dissipation (Operation)				1	W
R _{ΘJA}	Thermal Resistance	SOP10 Package		140		°C/W
Protection						
LED _S	LED Short Protection			0.64		V
OTP _{NTC}				0.3		V
TFP _{NTC}	Thermal Foldback Protection			0.5		V
Note:						
1. I _{LED} =0.6/R _{EXT} , V _{FF} =0V, D _{IM} =0V, LED _S =0V, NTC pin is connected to V _S pin.						
2. V _{FF} =0V, D _{IM} =0V, LED _S =0V, NTC pin is connected to V _S pin.						

FUNCTION DIAGRAM

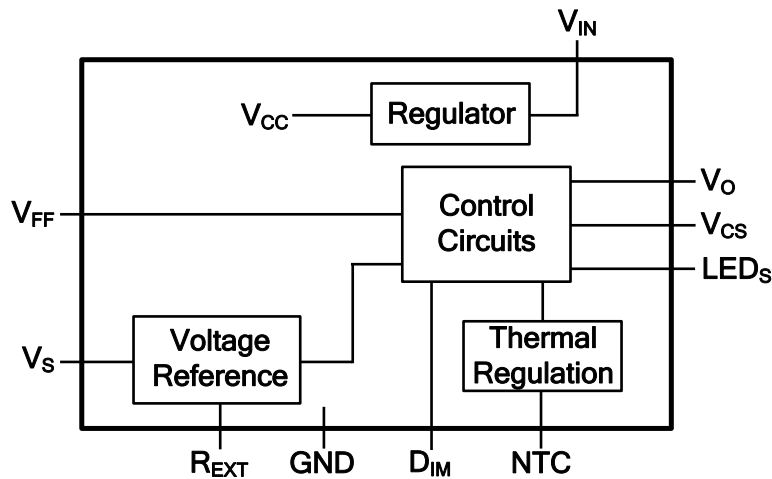

Fig. 2 Detailed Block Diagram

PIN DESCRIPTIONS

PIN	Symbol	Description
1	V_{IN}	Input supply voltage.
2	GND	All external components are connected to ground pin with shortest loops feasible.
3	V_{FF}	Input voltage sensing through a voltage divider for constant output power regulation.
4	D_{IM}	Connect a logic level PWM signal for adjustable brightness of LED strings.
5	V_S	External voltage reference for thermal foldback circuit.
6	NTC	Connect a divider of a resistor and thermistor from V_S to monitor the temperature of the LEDs or the N-channel MOSFET.
7	LED _S	LED Short Protection.
8	R_{EXT}	An external resistor between R_{EXT} and GND pin sets different current regulation for LED strings.
9	V_{CS}	A resistor is connected between V_{CS} and R_{EXT} pin for over current protection.
10	V_O	Connect to gate of N-channel MOSFET.

Ordering Information

EC4213NN XX R

└───┬───┬───
 └───┬───
 └───
 Tape Reel

Package:

M1=SOP-10L

Part No.	Package Type	Marking Information	Remark
EC4213NNM1R	SOP-10L	EC4213 LLLLL YYWWT	1. LLLLL : Lot No 2. YYWW : Date Code 3. T : Internal Tracking Code

LED Lighting EC4213 Application Circuit Schematic

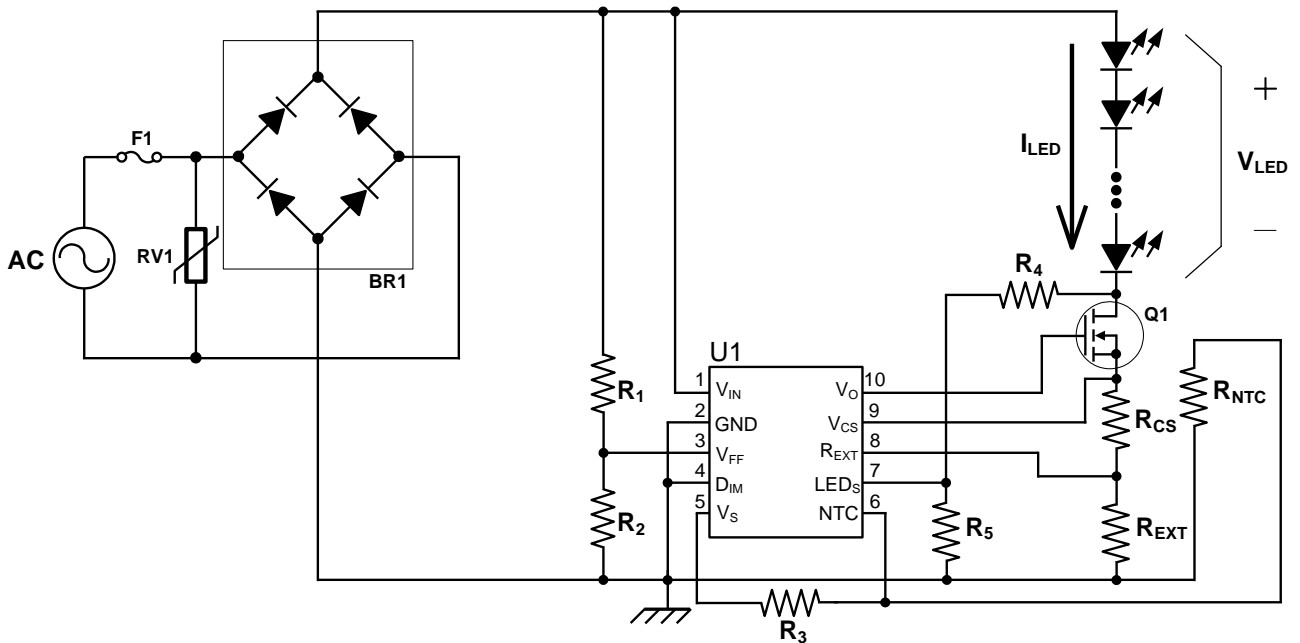
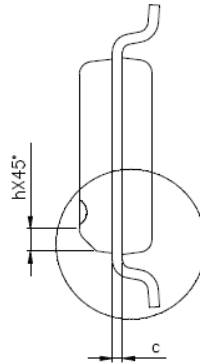
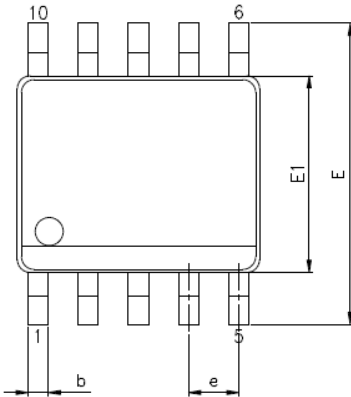

Fig. 3 Typical Application Circuit

220VAC 50W LED Lighting Demo Board Part List

COMPONENT	VALUE	PACKAGE
U1	EC4213	SOP10
F1	1A	DIP
BR1	B10S	SMD
Q1	4A	TO220
RV1	431KD14 (275VAC)	DIP
R ₁	5.11MEG	0603
R ₂	14.7k	0603
R ₃	7.5k	0603
R ₄	5.11MEG	0603
R ₅	18k	0603
R _{CS}	0.15	0805
R _{EXT}	1.3	DIP
R _{NTC}	100k	DIP
V _{LED}	240V	NA

OUTLINE DIMENSIONS (Dimensions shown in millimeters)



SYMBOLS	MIN.	MAX.
A	—	1.75
A1	0.10	0.25
A2	1.25	—
b	0.30	0.45
c	0.10	0.25
D	4.90 BSC	
E	6.00 BSC	
E1	3.90 BSC	
e	1.00 BSC	
L	0.40	1.27
h	0.25	0.50
θ°	0	8

UNIT : mm

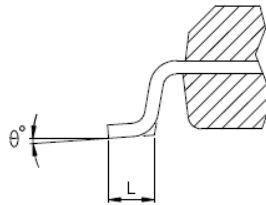
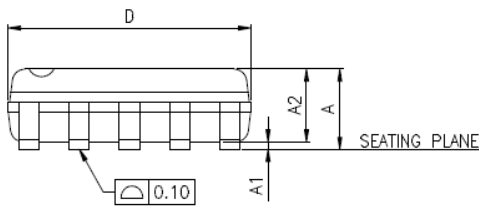

NOTES:

1. JEDEC OUTLINE : N/A.
2. DIMENSIONS "D" DOES NOT INCLUDE MOLD FLASH, INCH PROTRUSIONS OR GATE BURRS. MOLD FLASH, PROTRUSIONS AND GATE BURRS SHALL NOT EXCEED 0.15mm PER SIDE.
3. DIMENSIONS "E1" DOES NOT INCLUDE INTER-LEAD FLASH, OR PROTRUSIONS. INTER-LEAD FLASH AND PROTRUSIONS SHALL NOT EXCEED 0.25mm PER SIDE.