



General Description

The EC49020 is a 4.5-20V input, 2A single-cell synchronous Li-Ion battery switching charger, suitable for portable application. The EC49020 integrates a synchronous PWM controller, 20V rating power MOSFETs, current sense resistor, high-accuracy current and voltage regulation, and charge termination, into a compact 8-pin SOP(Expose PAD) package.

Features

- ◆ 1.5MHz Synchronous Switching Charger with Integrated Power FETs
- ◆ Up to 93% Efficiency
- ◆ 20V Input Rating with 6.7V OVP
- ◆ Programmable (2A Max) Charge Current
- ◆ Built-in Charge Current Soft Start
- ◆ Built-in Reverse Current Blocking Diode
- ◆ Built-in Charge Current Sense Resistor
- ◆ Output Short Circuit Protection
- ◆ Over Temperature Protection
- ◆ Available in a SOP8(Expose PAD) Package

Applications

- ◆ Tablet PC, Ebook and Netbook
- ◆ Handheld Portable Media Products
- ◆ Power Bank

Ordering Information

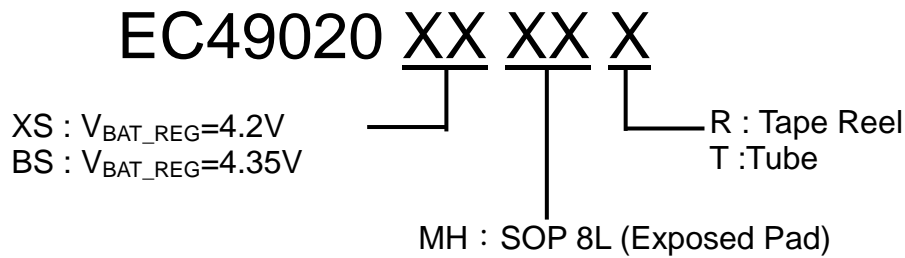

Part No.	Marking	Temp. Range	Package	Remark
EC49020XSMHR EC49020XSMHT	49020 LLLLL YYWWX	-40°C ~85°C	SOP 8L (Exposed PAD)	1. LLLLL : LOT NO. 2. YYWW : Date code 3. X : $V_{BAT_REG}=4.2V$
EC49020BSMHR EC49020BSMHT	49020 LLLLL YYWWB	-40°C ~85°C	SOP 8L (Exposed PAD)	1. LLLLL : LOT NO. 2. YYWW : Date code 3. B : $V_{BAT_REG}=4.35V$



High Efficiency 2A 1.5MHz Single Cell Li-ion Battery Switching Charger

Pin Configuration

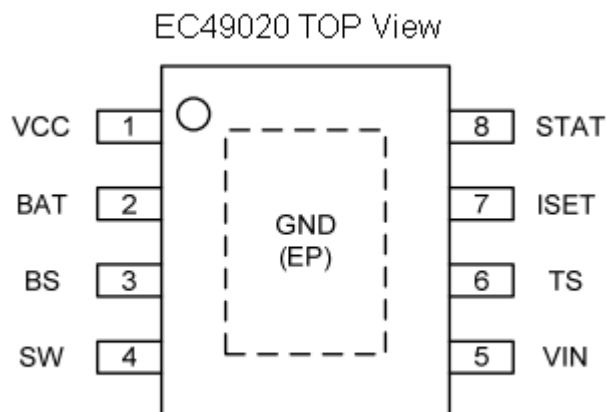

Pin Description

Pin NO.	Pin Name	Description		
1	V _{CC}	5V linear regulator output. Bypass a 2.2uF ceramic capacitor from V _{CC} to GND.		
2	BAT	Battery connection. Connect to the positive terminal of the battery. Bypass BAT to GND with a 20uF capacitor.		
3	BS	High Side MOSFET Gate Driver Supply. Connect a 0.1uF ceramic capacitor from BS to SW to supply the gate drive for the high side MOSFETs.		
4	SW	Switching node. Connect SW to the external inductor.		
5	V _{IN}	IC power supply of internal bias and power devices. Bypass 20uF MLCC ceramic capacitor from V _{IN} to GND.		
6	TS	Battery Pack NTC Monitor. Connect TS to the center tap of a resistor divider from V _{CC} to GND. Pull TS to GND and disable charge function.		
7	I _{SET}	Charge Current Programming Input. Connect a resistor R _{ISET} from I _{SET} to GND to program the charge current. The charge current is programmable from 0.5A to 2A.		
8	STAT	Charge Status Open Drain Output. STAT is pulled low when a charge cycle starts and remains low while charging. STAT is high impedance when the charging terminates and when no supply exists. STAT is blinking when IC detect fault conditions.		
		HIGH	LOW	Blinking
		Charge complete	Charge in progress	Fault
EP	GND	The exposed thermal pad and the IC ground pin.		

Typical Operating Circuit

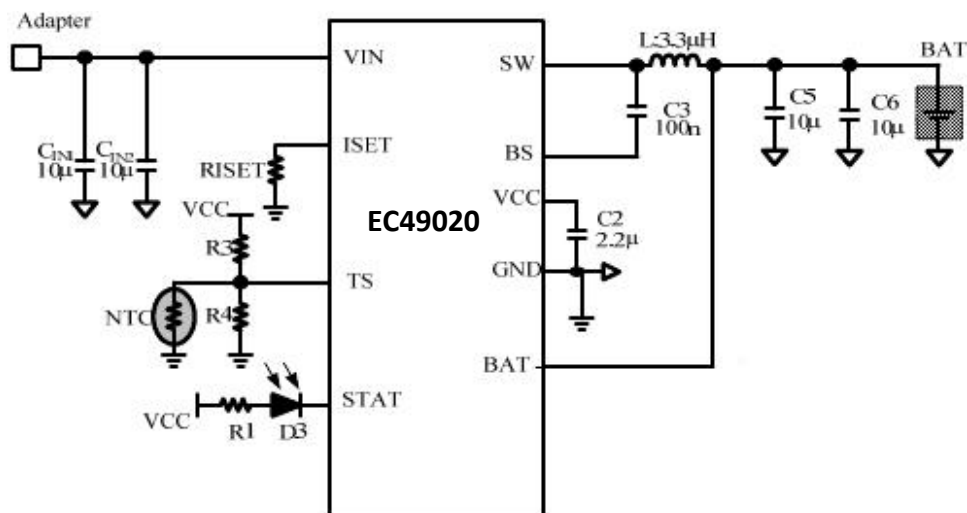

Electrical Characteristics

Absolute Maximum Ratings (1)

V_{IN} , STAT to GND	-0.3V~20V	Junction temperature range, T_J	-40°C ~155°C
BS to GND.....	-0.3V~26V	Storage temperature range, T_{stg}	-55°C ~155°C
SW to GND.....	-2~20V	Lead Temperature.....	260°C
V_{CC} , ISET, TS, BAT to GND	-0.3V~6V		

Thermal information

Maximum Power Dissipation($T_A=+25^\circ\text{C}$).....	2.4W	Thermal resistance(θ_{JA})	41.3°C/W
---	------	---	----------

Recommend Operating Conditions (2)

Input Voltage (V_{IN})	+4.5V to +6.5V	Ambient Temperature Range	-40°C to +85°C
----------------------------------	----------------	---------------------------------	----------------

Note (1): Stress beyond those listed under “Absolute Maximum Ratings” may damage the device.

Note (2): The device is not guaranteed to function outside the recommended operating conditions.



High Efficiency 2A 1.5MHz Single Cell Li-ion Battery Switching Charger

EC49020

Electrical Characteristics

$V_{IN}=5V$, typical values are at $T_A = +25^\circ C$, with respect to GND

PARAMETER	TEST CONDITIONS	MIN	TYP	MAX	UNITS
INPUT VOLTAGE					
V_{IN} Supply Operating Range		4.5		6.5	V
V_{UVLO} Under-voltage lockout threshold	Measure on V_{IN} 0V→4V		3.3		V
V_{UVLO_HYS} Hysteresis on UVLO	Measure on V_{IN} 4V→0V		300		mV
V_{OVP} Over-Voltage Rising	V_{IN} rising 5V→7V	6.55	6.75	6.95	V
V_{OVP_HYS} Hysteresis on OVP	V_{IN} falling 7V→5V		100		mV
AUTOMATIC SLEEP COMPARATOR (REVERSE DISCHARGING PROTECTION)					
V_{SLEEP} SLEEP mode threshold	$V_{IN} - V_{BAT}$ falling		100		mV
V_{SLEEP_HYS} Hysteresis	$V_{IN} - V_{BAT}$ rising		200		mV
QUIESCENT CURRENTS					
I_{BAT} Battery discharge current	Pull TS to GND			25	μA
I_{AC} Adapter supply current	$V_{IN} > V_{UVLO}$, $V_{IN} > V_{BAT}$, $V_{BAT} > V_{BAT_REG}$, Charge disabled		1.2	2.0	mA
CHARGE VOLTAGE REGULATION					
V_{BAT_REG} BAT regulation voltage	EC49020XS, measured on BAT $0^\circ C \leq T_A \leq +70^\circ C$	4.158	4.200	4.242	V
	EC49020BS, measured on BAT $0^\circ C \leq T_A \leq +70^\circ C$	4.306	4.350	4.393	
V_{RCHG} Recharge Threshold, belowregulation voltage limit	1 cell, measured on BAT $V_{BAT_REG} - V_{BAT}$		100		mV
V_{LOWV} Trickle Charge to fast charge transition threshold	measured on BAT		2.9		V
V_{OV_BAT} BAT Over-voltage Threshold	As percentage of V_{BAT_REG}		104%		
CHARGE CURRENT REGULATION					
I_{OUT} Charge Current Limit	$V_{BAT(REG)} > V_{BAT} > V_{LOWV}$; $I_{OUT} = K_{ISET} / R_{ISET}$; $R_{ISET} = 40k\Omega$ to $200k\Omega$	0.5		2	A
K_{ISET} Fast charge current factor	$R_{ISET} = K_{ISET} / I_{OUT}$; $0.5A < I_{OUT} < 2A$		100		A·kΩ
% I_{TRICHG} Trickle Charge Current	$V_{BAT} < V_{LOWV}$		10		% I_{OUT}
% I_{TERM} Termination Current	$V_{BAT} > V_{RCHG}$		10		% I_{OUT}
THERMISTOR COMPARATOR					
V_{LTF} Cold Temperature Threshold, TS pin Voltage Rising Threshold	Charger suspends charge. As percentage to V_{CC}	70.5%	73.5%	76.5%	
V_{LTF_HYS} Cold Temperature Hysteresis, TS pin voltage Falling	As percentage to V_{CC}		0.4%		
V_{HTF} Hot Temperature TS pin voltage rising Threshold	As percentage to V_{CC}		47%		
V_{TCO} Cut-off Temperature TS pin Voltage falling Threshold	As percentage to V_{CC}	41.7%	44.7%	47.7%	
V_{OFF} Charging Disable Threshold TS pin voltage falling edge	Hysteresis 0.15V			0.15	V
INTERNAL THERMAL REGULATION					
T_{J_REG} Temperature Regulation Limit	Charging		125		°C



High Efficiency 2A 1.5MHz Single Cell Li-ion Battery Switching Charger

EC49020

$T_{J(OFF)}$	Thermal Shutdown Temperature		160		°C		
$T_{J(OFF-HYS)}$	Thermal Shutdown Hysteresis		20		°C		
INTERNAL PWM Driver							
fsw	PWM Switching Frequency		1200	1500	1700	kHz	
I_{OCP_HSFET}	Peak Current limit	Measure on High Side FET		4		A	
R_{DS_HI}		High Side MOSFET On Resistance		150		mΩ	
R_{DS_LO}		Low Side MOSFET On Resistance		75		mΩ	
VCC REGULATOR							
V_{CC_REG}	V_{CC} regulator voltage	$V_{IN} > 6 V$,		4.0	5	5.5	V
I_{VCC_LIM}	V_{CC} current limit	$V_{CC} = 0 V$			50		mA

Functional Block Diagram

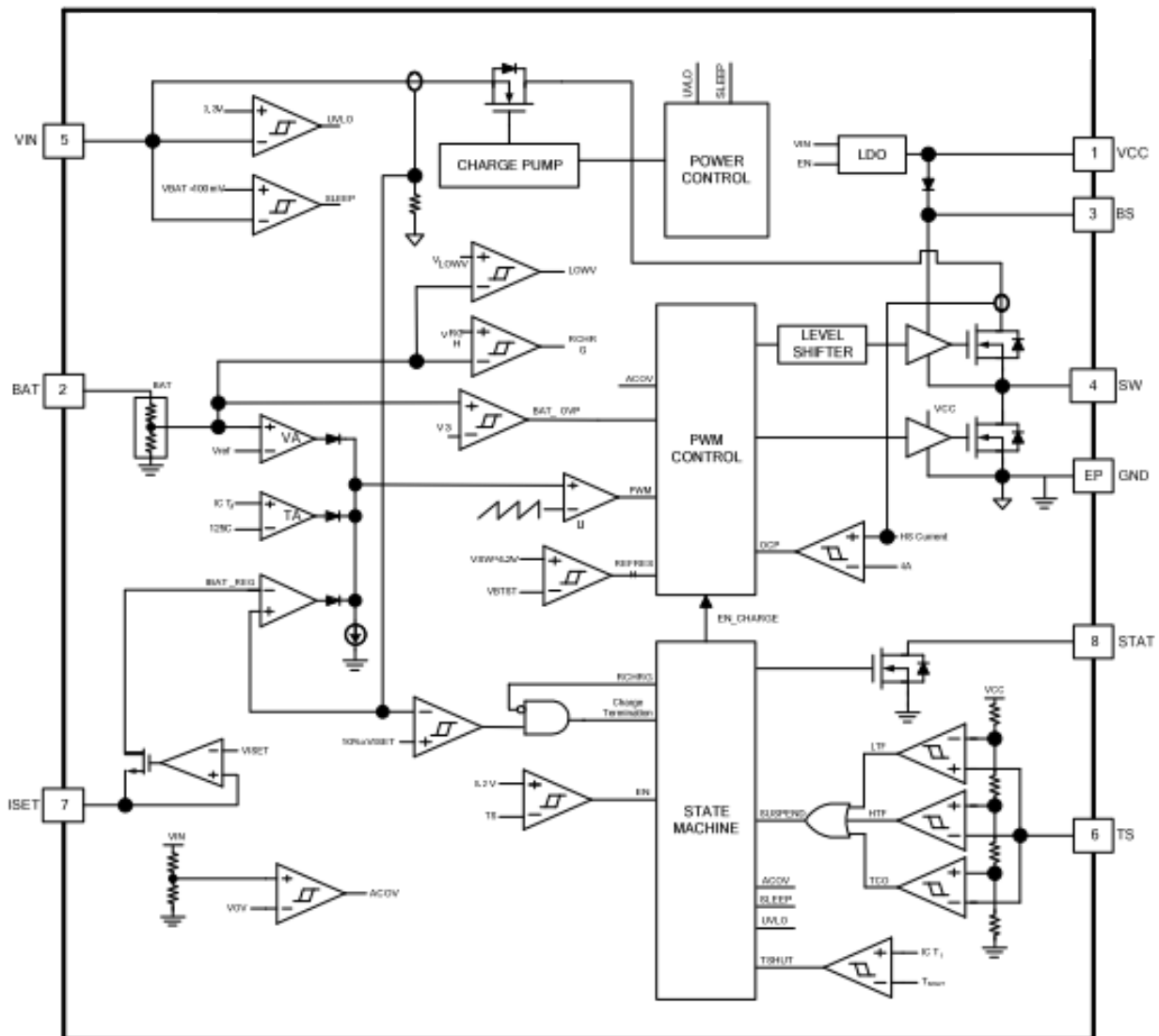

Typical Performance Characteristics

$V_{IN} = 5V$, $R_{ISET} = 50k\Omega$, Typical Application Circuit Figure 1, $T_A = +25^\circ C$, unless otherwise noted

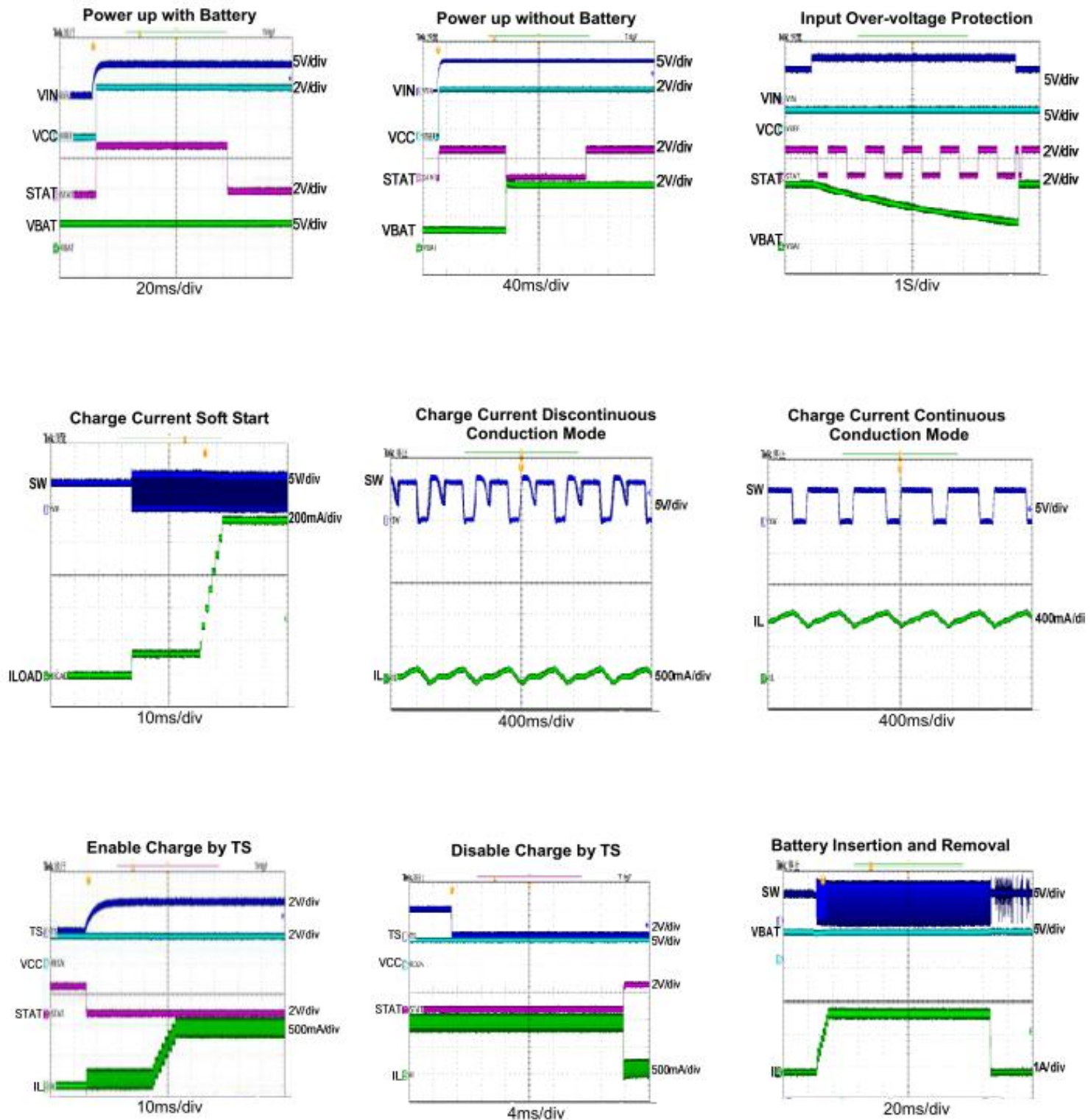

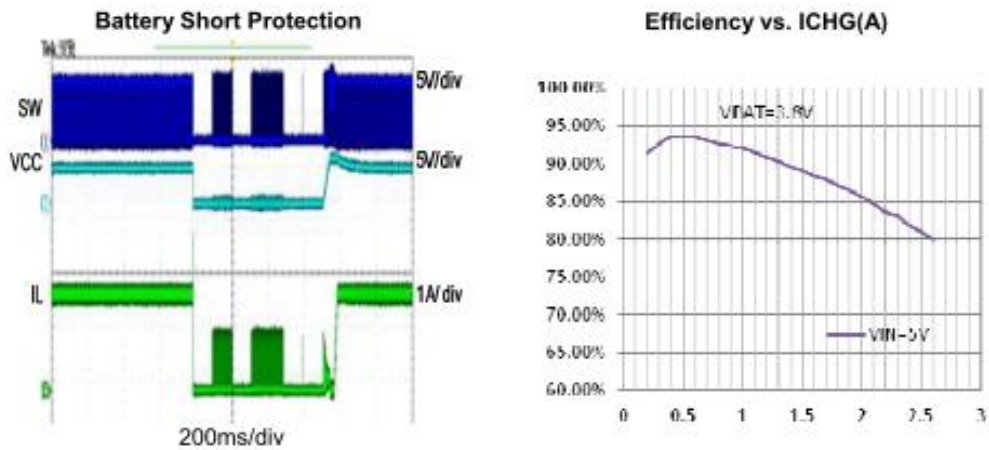

Typical Application Circuit

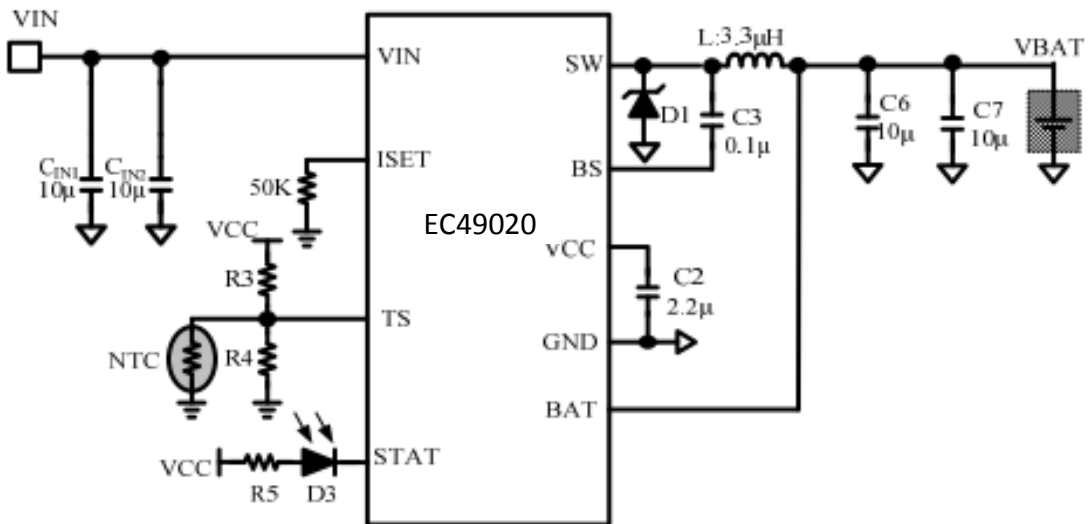

Figure 1. EC49020 $I_{CHG}=2A$ Typical Application Circuit

Detailed Description

The EC49020 family is an integrated charger optimized for charging 1-cell Li-ion or Li-polymer batteries. It charges a battery with constant current (CC) and constant voltage (CV) profile. The typical charge profile is illustrated in Figure 2.

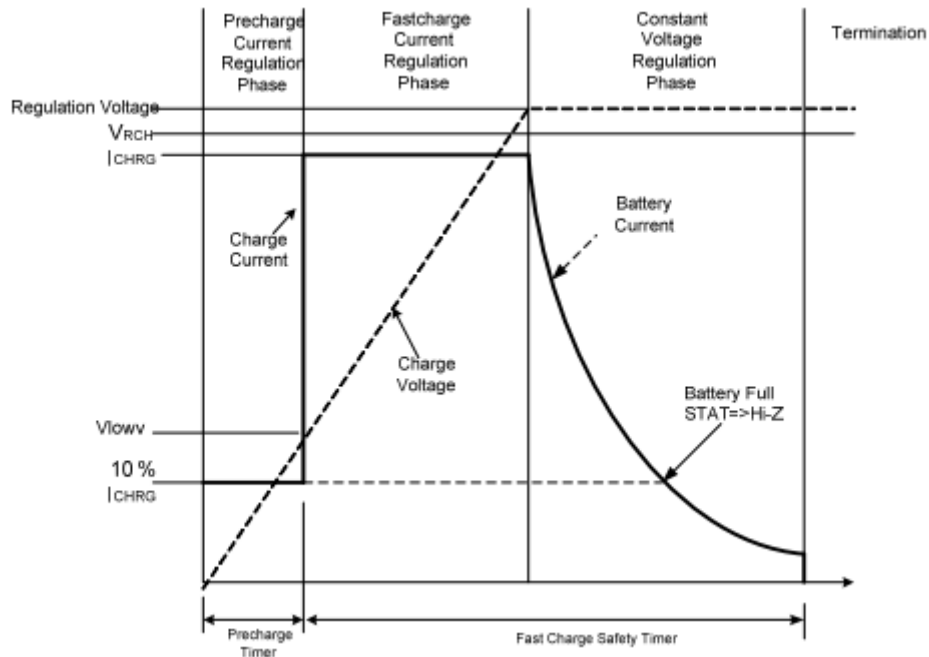

Figure 2. EC49020 Typical Charge Profile

Battery Charge Current Regulation

The charge current up to 2A is programmed by a resistor R_{ISET} from I_{SET} to ground. The charge current is calculated by the following equation:

$$I_{CHG} = \frac{K_{ISET}}{R_{ISET}} = \frac{100A \cdot k\Omega}{R_{ISET}}$$

The valid resistor range is 40kΩ to 200kΩ (See Table 1.) Under high ambient temperature, the charge current will be fold back to keep IC junction temperature not exceeding +125°C.

Table 1. Charge Current Settings

R _{ISET} (kΩ)	Charge Current (A)
50	2.0
66.7	1.5
100	1.0
200	0.5

Battery Trickle Charge Current Regulation

During power-up, if the battery voltage is below the V_{LOWV} threshold, the EC49020 only applies the trickle charge current into the battery. This trickle charge feature is intended to revive deeply discharged cells. If the V_{LOWV} threshold is not reached within 30 minutes of initiating trickle charge, the charger is turned off, and STAT pin blinks to indicate a FAULT condition. For EC49020 series, the trickle charge current is set as 10% of the full charge current.

Charge Termination

The EC49020 monitor the charge current during the battery voltage regulation phase. Charge termination is set when the battery voltage is higher than recharge threshold V_{RCH} and the charge current is less than 10% of the full charge current.

Recharge

A new charge cycle is initiated when one of the following conditions occurs:

The battery voltage falls below the recharge threshold Input supply V_{IN} power-on-reset (POR) event occurs TS pin is toggled below 0.15V (disable charging) and above 0.3V (enable charging).

Charge Current Soft Start

The EC49020 soft starts the charge current to ensure no overshoot or stress on the output capacitors or the power converter.

The Thermistor Input TS

The EC49020 continuously monitors battery temperature by measuring the voltage between the TS pin and GND. A negative temperature coefficient thermistor (NTC) and an external voltage divider typically develop this voltage. The EC49020 compares this voltage against its internal thresholds to determine if charging is allowed. To initiate a charge cycle, the battery temperature must be within the V_{LTF} to V_{HTF} thresholds. If battery temperature is outside of this range, the EC49020 suspends charge and waits until the battery temperature is within the V_{LTF} to V_{HTF} range. During the charge cycle the battery temperature must be within the V_{LTF} to V_{TCO} threshold.

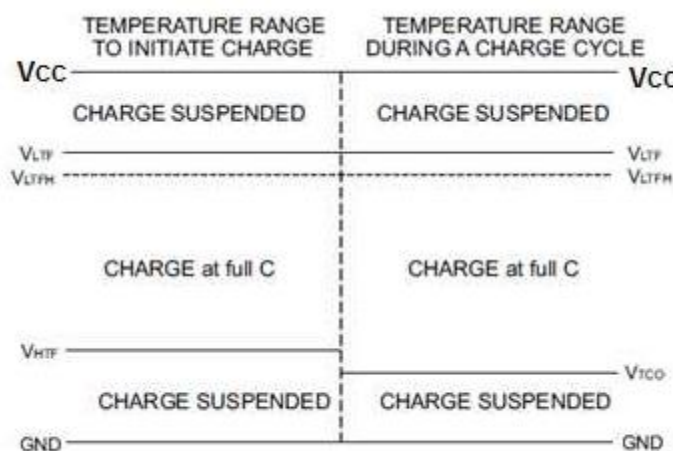

Figure 3. Thermistor Input TS Pin Threshold

Refer to EC49020 typical operating circuit. RTHHOT is the expected thermistor resistance at the programmed hot threshold, and RTHCOLD is the expected thermistor resistance at the programmed cold threshold. The values of R3 and R4 can be determined by using below equations.

$$R4 = \frac{V_{CC} \times RTH_{COLD} \times RTH_{HOT} \times \left[\frac{1}{V_{LTF}} - \frac{1}{V_{TCO}} \right]}{RTH_{HOT} \times \left[\frac{V_{CC}}{V_{TCO}} - 1 \right] - RTH_{COLD} \times \left[\frac{V_{CC}}{V_{LTF}} - 1 \right]}$$

$$R3 = \frac{\frac{V_{CC} - 1}{V_{LTF}}}{\frac{1}{R4} + \frac{1}{RTH_{COLD}}}$$

Where:

$$V_{LTF} = 0.735 \times V_{CC}$$

$$V_{TCO} = 0.447 \times V_{CC}$$

PCB Layout Consideration

For the best efficiency and minimum noise problem, Place C_{IN}, C6, C7, C2, L, R_{ISSET}, R3 and R4 close to the IC. Maximize the PCB copper area connecting to GND pin to achieve the best thermal and noise performance. If the board space allowed, a ground plane is highly desirable. C_{IN} must be close to Pins IN and GND. The loop area formed by C_{IN} and GND must be minimized. The PCB copper area associated with SW pin must be minimized to avoid the potential noise problem.

Packaging Information

EC49020 SOP 8L 150mils(EP) PACKAGE OUTLINE DIMENSIONS

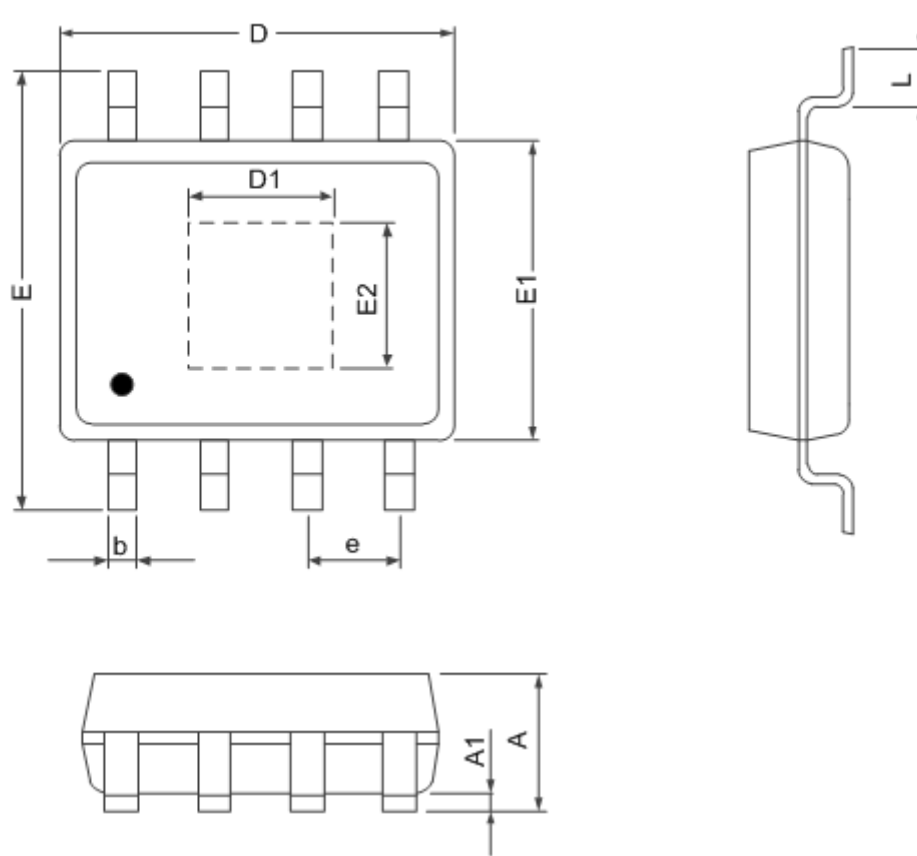

SYMBOLS	MILLIMETERS		INCHES	
	MIN.	MAX.	MIN.	MIN.
A	1.35	1.75	0.053	0.069
A1	0.00	0.25	0.000	0.010
D	4.90		0.193	
E1	3.90		0.153	
D1	3.30		0.130	
E2	2.40		0.095	
E	5.80	6.20	0.228	0.244
L	0.40	1.27	0.016	0.050
b	0.31	0.51	0.012	0.020
e	1.27		0.050	