

General Description

The EC5015A is a current mode monolithic buck switching regulator. Operating with an input range of 3.6V~40V, The EC5015A delivers 2A of continuous output current with two integrated N-Channel MOSFETs. The internal synchronous power switches provide high efficiency without the use of an external Schottky diode. At light loads, regulators operate in low frequency to maintain high efficiency and low output ripple. Current mode control provides tight load transient response and cycle-by-cycle current limit. The EC5015A guarantees robustness with short-circuit protection, thermal protection, start-up current run-away protection, and input under voltage lockout. The EC5015A is available in 8-pin ESOP package, which provides a compact solution with minimal external components. The package has an exposed pad for low thermal resistance.

Features

- ◆ 3.6 V to 40 V operating input range
- ◆ 2A output current
- ◆ Up to 94% efficiency
- ◆ High efficiency (>78%) at light load
- ◆ Internal Soft-Start
- ◆ Fixed 440kHz Switching frequency
- ◆ Input under voltage lockout
- ◆ Available in thermally enhanced ESOP8 package
- ◆ Start-up current run-away protection
- ◆ Short circuit protection
- ◆ Thermal protection

Applications

- ◆ Distributed Power Systems
- ◆ Networking Systems
- ◆ FPGA, DSP, ASIC Power Supplies
- ◆ Green Electronics/ Appliances
- ◆ Notebook Computers

Typical application

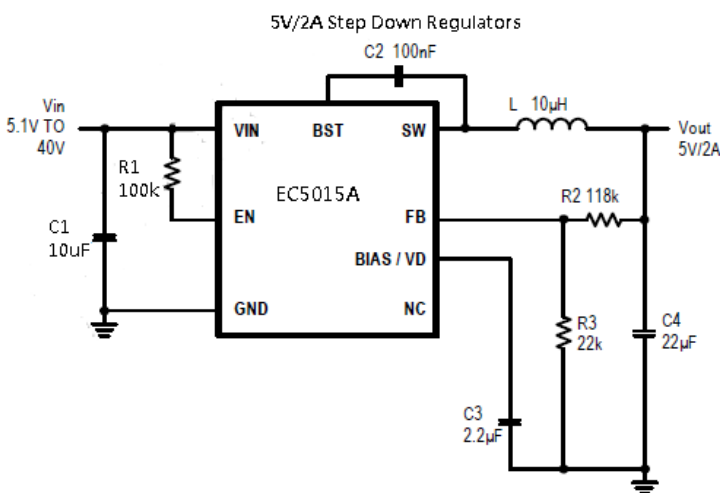

Efficiency vs Load Current
(Vout = 5V)

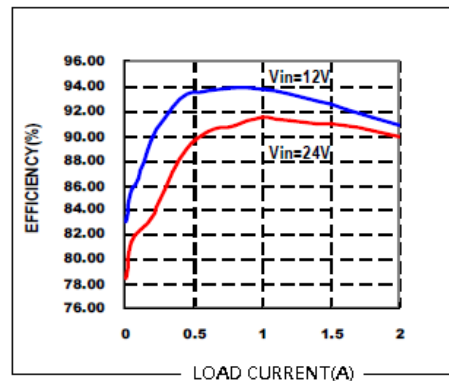

Ordering/Marking Information

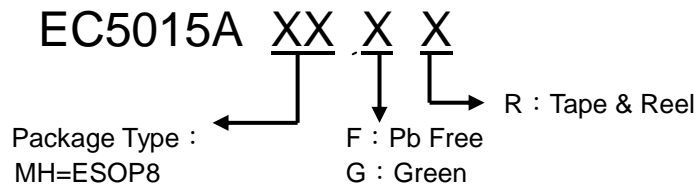

Device	Marking	Package	Information
EC5015AMHXR	EC5015 LLLLL YYWW	ESOP8	YY: Year code WW: Week code LLLLL: Lot no.

Pin Configurations

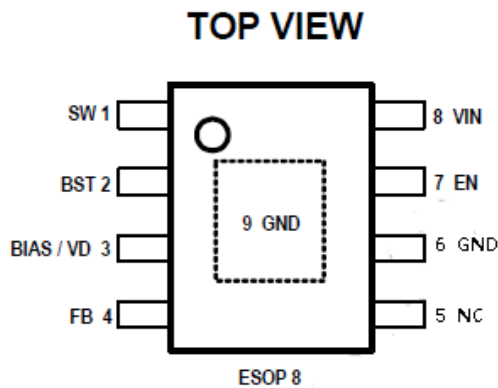

The pad and Pin-6 must be connected to GND.

Absolute Maximum Ratings

VIN, EN, SW Pin.....	-0.3V to 44V
BST Pin.....	SW-0.3Vto SW+5V
All other Pins.....	-0.3Vto 6V
Junction Temperature ^{2) 3)}	150°C
Lead Temperature.....	260°C
Storage Temperature.....	-65°C to +150°C

Recommended Operating Conditions

Input Voltage VIN.....	3.6Vto 40V
Output Voltage Vout.....	0.8Vto 37V
Operating Junction Temperature.....	-40°C to 125°C

Thermal Performance

ESOP8	θ_{JA}	θ_{JC}
Note :	50....10°C/W	

1) Exceeding these ratings may damage the device.

2) The EC5015A guarantees robust performance from -40°C to 150°C junction temperature. The junction temperature range specification is assured by design, characterization and correlation with statistical process controls.

3) The EC5015A includes thermal protection that is intended to protect the device in overload conditions.

Thermal protection is active when junction temperature exceeds the maximum operating junction temperature. Continuous operation over the specified absolute maximum operating junction temperature may damage the device.

4) Measured on JESD51-7, 4-layer PCB.



2A, 40V Synchronous Step-Down Converter

EC5015A

Electrical Characteristics

$V_{IN} = 12V$, $T_A = 25^{\circ}C$, unless otherwise stated.

Item	Symbol	Condition	Min.	Typ.	Max.	Units
VIN Undervoltage Lockout Threshold	V_{IN_MIN}	V_{IN} falling	2.8	3.4	3.6	V
VIN Undervoltage Lockout Hysteresis	$V_{IN_MIN_HYST}$	V_{IN} rising	140	270	360	mV
Shutdown Supply Current	I_{SD}	$V_{IN}=40V$, $V_{EN}=0V$		0	1	μA
Supply Current	I_Q	$V_{EN}=5V$, $V_{FB}=1V$		65	95	μA
Feedback Voltage	V_{FB}	$3.6V < V_{VIN} < 40V$	0.788	0.8	0.812	V
Top Switch Resistance ⁵⁾	$R_{DS(ON)T}$			126	206	m
Bottom Switch Resistance ⁵⁾	$R_{DS(ON)B}$			63	103	m
Top Switch Leakage Current	I_{LEAK_TOP}	$V_{IN}=40V$, $V_{EN}=0V$, $V_{SW}=0V$		0	1	μA
Bottom Switch Leakage Current	I_{LEAK_BOT}	$V_{IN}=V_{SW}=40V$, $V_{EN}=0V$		0	1	μA
Top Switch Current Limit ⁵⁾	I_{LIM_TOP}	Minimum Duty Cycle	3	3.7		A
Switch Frequency	f_{SW}		220	440	660	kHz
Minimum On Time ⁵⁾	T_{ON_MIN}			117		ns
Minimum Off Time ⁵⁾	T_{OFF_MIN}	$V_{FB}=0V$		112		ns
EN shut down threshold voltage	V_{EN_TH}	V_{EN} falling, $FB=0V$	1	1.2	1.43	V
EN shut down hysteresis	V_{EN_HYST}	V_{EN} rising, $FB=0V$		140	200	mV
Thermal Shutdown ⁵⁾	T_{TSD}			135		$^{\circ}C$
Thermal Shutdown hysteresis ⁵⁾	T_{TSD_HYST}			15		$^{\circ}C$

Note :

5) Guaranteed by design.

Pin Description

ESOP8 Pin	Name	Description
1	SW	SW is the switching node that supplies power to the output. Connect the output LC filter from SW to the output load.
2	BST	Bootstrap pin for top switch. A 0.1uF or larger capacitor should be connected between this pin and the SW pin to supply current to the top switch and top switch driver.
3	BIAS/VD	Output of the internal LDO. A capacitor of 2.2uF or larger should be connected at VD To ground.
4	FB	Output feedback pin. FB senses the output voltage and is regulated by the control loop To 0.8V. Connect a resistive divider at FB.
5	NC	
6/9	GND	Ground.
7	EN	Drive EN pin high to turn on the regulator and low to turn off the regulator.
8	VIN	Input voltage pin. VIN supplies power to the IC. Connect a 3.6V to 40V supply to VIN And bypass VIN to GND with a suitably large capacitor to eliminate noise on the input to the IC.

Block Diagram

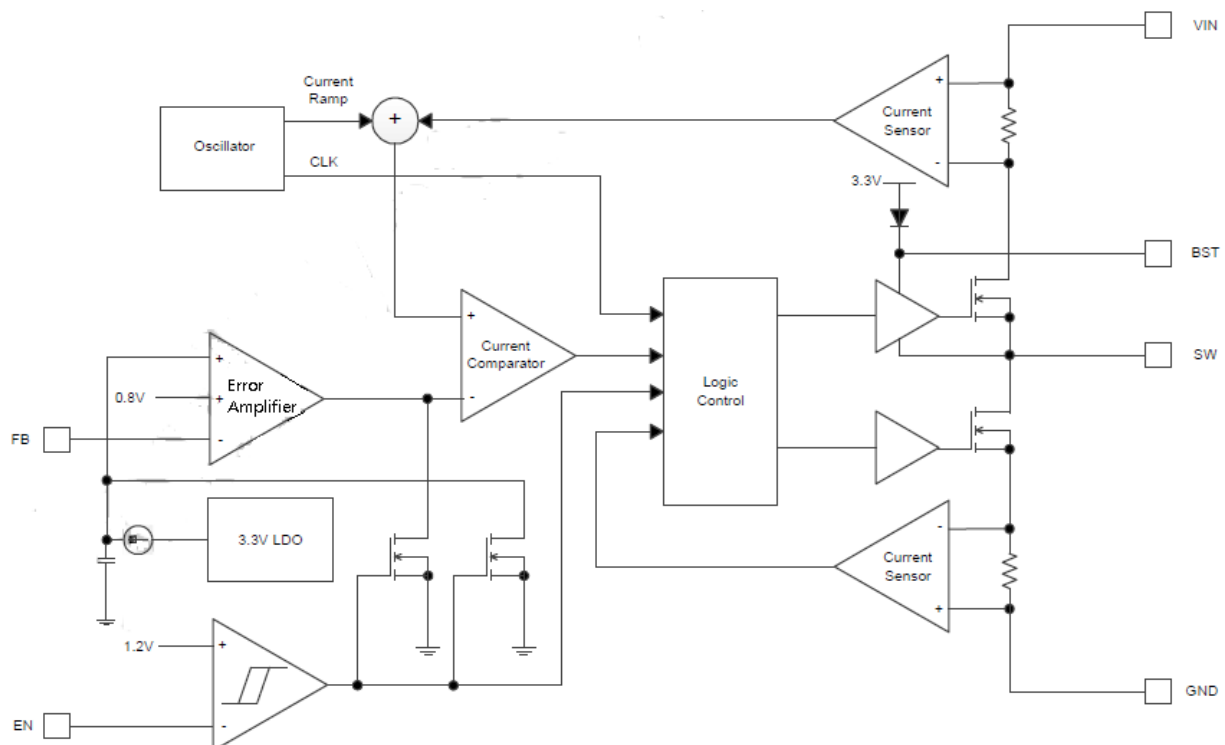

Typical Performance Characteristics

$V_{in} = 12V$, $V_o = 5V$, $L = 10\mu H$, $C_{out} = 10\mu F$, $T_A = +25^\circ C$, unless otherwise noted

Steady State Test

$V_{in}=12V$, $V_{out}=5V$
 $I_{out}=2A, I_{in}=0.65A$

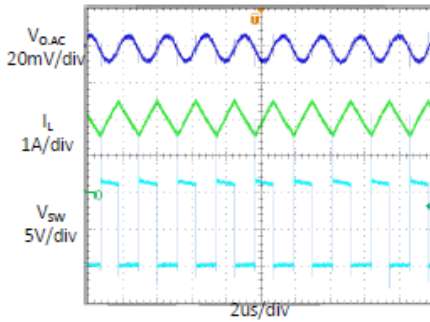

Startup through Enable

$V_{in}=12V$, $V_{out}=5V$
 $I_{out}=1A$ (Resistive load)

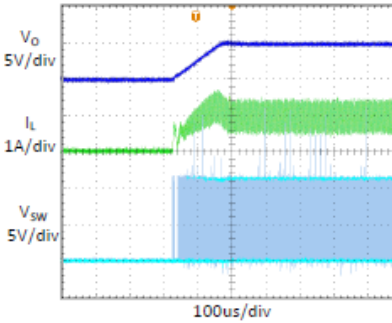

Shutdown through Enable

$V_{in}=12V$, $V_{out}=5V$
 $I_{out}=1A$ (Resistive load)

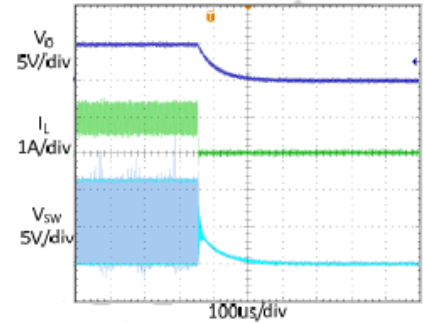

Heavy Load Operation

2A LOAD

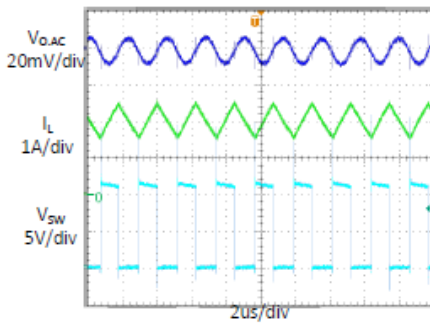

Medium Load Operation

1A LOAD

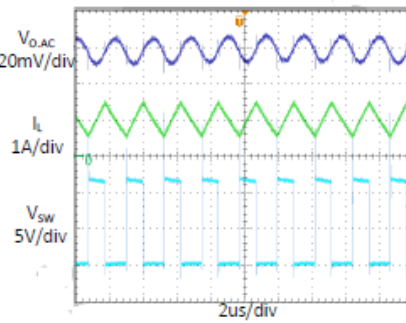

Light Load Operation

0.3A LOAD

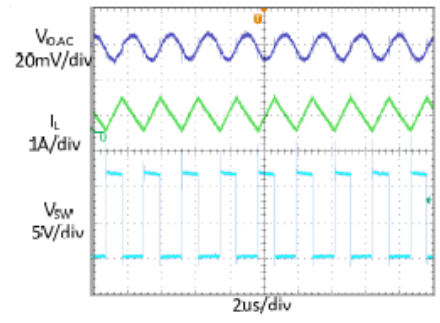

Short Circuit Protection

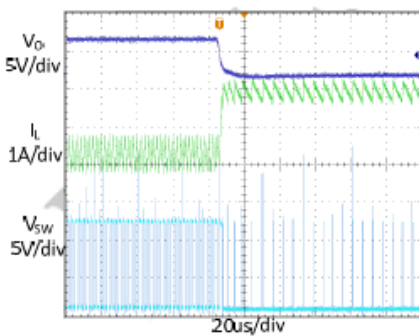

Short Circuit Recovery

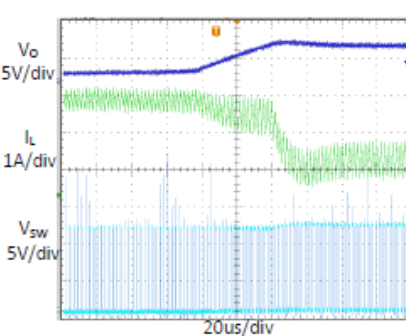

Load Transient

1A LOAD \rightarrow 2A LOAD \rightarrow 1A LOAD

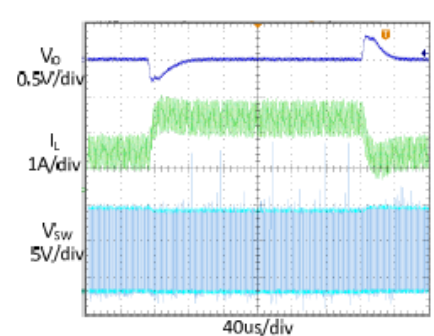



Functional Description

The EC5015A is a synchronous, current-mode, step-down regulator. It regulates input voltage from 3.6V to 40V down to an output voltage as low as 0.8V, and is capable of supplying up to 2A of load current.

Current-Mode Control

The EC5015A utilizes current-mode control to regulate the output voltage. The output voltage is measured at the FB pin through a resistive voltage divider and the error is amplified by the internal transconductance error amplifier. Output of the internal error amplifier is compared with the switch current measured internally to control the output current limit.

PFM Mode

The EC5015A operates in PFM mode at light load. In PFM mode, switch frequency is continuously controlled in proportion to the load current, i.e. switch frequency is decreased when load current drops to boost power efficiency at light load by reducing switch-loss, while switch frequency is increased when load current rises, minimizing both load current and output voltage ripples.

Shut-Down Mode

The EC5015A operates in shut-down mode when voltage at EN pin is driven below 0.3V. In shut-down mode, the entire regulator is off and the supply current consumed by the EC5015A drops below 0.1 μ A.

Power Switch

N-Channel MOSFET switches are integrated on the EC5015A to down convert the input voltage to the regulated output voltage. Since the top MOSFET needs a gate voltage greater than the input voltage, a boost capacitor connected between BST and SW pins is required to drive the gate of the top switch. The boost capacitor is charged by the internal 3.3V rail when SW is low.

Vin Under-Voltage Protection

A resistive divider can be connected between Vin and ground, with the central tap connected to EN, so that when Vin drops to the pre-set value, EN drops below 1.2V to trigger input under voltage lockout protection.

Output Current Run-Away Protection

At start-up, due to the high voltage at input and low voltage at output, current inertia of the output inductance can be easily built up, resulting in a large start-up output current. A valley current limit is designed in the EC5015A so that only when output current drops below the valley current limit can the bottom power switch be turned off. By such control mechanism, the output current at start-up is well controlled.

Output Short Protection

When output is shorted to ground, output current rapidly reaches its peak current limit and the top power switch is turned off. Right after the top power switch is turned off, the bottom power switch is turned on and stay on until the output current falls below the valley current limit. When output current is below the valley current limit, the top power switch will be turned on again and if the output short is still present, the top power switch is turned off when the peak current limit is reached and the bottom power switch is turned on. This cycle goes on until the output short is removed and the regulator comes into normal operation again.

Thermal Protection

When the temperature of the EC5015A rises above 135°C, it is forced into thermal shut-down. Only when core temperature drops below 120°C can the regulator becomes active again.

Application Information

Output Voltage Set

The output voltage is determined by the resistor divider connected at the FB pin, and the voltage ratio is:

$$V_{FB} = V_{OUT} \cdot \frac{R_3}{R_2 + R_3}$$

where V_{FB} is the feedback voltage and V_{OUT} is the output voltage. Choose R_3 around 10k, and then R_2 can be calculated by:

$$R_2 = R_3 \cdot \left(\frac{V_{OUT}}{0.8V} - 1 \right)$$

The following table lists the recommended values.

VOUT(V)	R3(k)	R2(k)
2.5	11.3	23.7
3.3	15.8	49.9
5	13	68.1

Input Capacitor

The input capacitor is used to supply the AC input current to the step-down converter and maintaining the DC input voltage. The ripple current through the input capacitor can be calculated by:

$$I_{C1} = I_{LOAD} \cdot \sqrt{\frac{V_{OUT}}{V_{IN}} \cdot \left(1 - \frac{V_{OUT}}{V_{IN}} \right)}$$

where I_{LOAD} is the load current, V_{OUT} is the output voltage, V_{IN} is the input voltage.

Thus the input capacitor can be calculated by the following equation when the input ripple voltage is determined.

$$C_1 = \frac{I_{LOAD}}{f_s \cdot \Delta V_{IN}} \cdot \frac{V_{OUT}}{V_{IN}} \cdot \left(1 - \frac{V_{OUT}}{V_{IN}} \right)$$

where C_1 is the input capacitance value, f_s is the switching frequency, V_{IN} is the input ripple voltage.

The input capacitor can be electrolytic, tantalum or ceramic. To minimizing the potential noise, a small X5R or X7R ceramic capacitor, i.e. 0.1uF, should be placed as close to the IC as possible when using electrolytic capacitors. A 10uF ceramic capacitor is recommended in typical application.

Output Capacitor

The output capacitor is required to maintain the DC output voltage, and the capacitance value determines the output ripple voltage. The output voltage ripple can be calculated by:

$$\Delta V_{OUT} = \frac{V_{OUT}}{f_s \cdot L} \cdot \left(1 - \frac{V_{OUT}}{V_{IN}} \right) \cdot \left(R_{ESR} + \frac{1}{8 \cdot f_s \cdot C_2} \right)$$

where C_2 is the output capacitance value and R_{ESR} is the equivalent series resistance value of the output capacitor. The output capacitor can be low ESR electrolytic, tantalum or ceramic. Lower ESR capacitors get lower output ripple voltage. The output capacitors also affect the system stability and transient response, and a 22uF ceramic capacitor is recommended in typical application.

Inductor

The inductor is used to supply constant current to the output load. The inductance determines the ripple current which affects the efficiency and the output voltage ripple. The ripple current is typically allowed to be 30% of the maximum switch current limit, thus the inductance value can be calculated by:

$$L = \frac{V_{OUT}}{f_s \cdot \Delta I_L} \cdot \left(1 - \frac{V_{OUT}}{V_{IN}} \right)$$

where VIN is the input voltage, VOUT is the output voltage, fs is the switching frequency, and IL is the peak-to-peak inductor ripple current.

External Bootstrap Capacitor

A bootstrap capacitor is required to supply voltage to the top switch driver. A 0.1uF low ESR ceramic capacitor is recommended To connected to the BST pin and SW pin.

External Bias Capacitor

A bias capacitor is required to provide compensation for the internal LDO. A 2.2uF low ESR ceramic capacitor is recommended To connect to the BIAS pin and GND.

PCB Layout Note

For minimum noise problem and best EMI performance, the PCB is preferred to following the guidelines and figure 1 as reference.

1. Place the input decoupling capacitor as close to EC5015A (VIN pin and PGND) as possible to eliminate noise at the input pin. The loop area formed by input capacitor and GND must be minimized.
2. Put the feedback trace as far away from the inductor and noisy power traces as possible.
3. Pin 9 GND must be connected to Pin 6 GND as close as possible.
4. To improve thermal conduction, put an array of vias right under the exposed pad. Use small vias (15mil barrel diameter) so that the holes can be filled during the plating process. Very large holes can cause 'solder-wicking' problems during the reflow soldering process. Use a via pitch (distance between the centers of two adjacent vias) of 40mil.

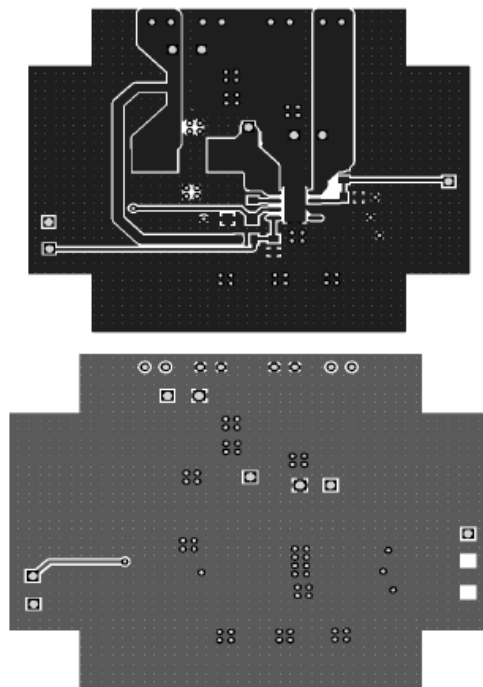

Reference Design

Reference 1 :

VIN : 3.6V ~ 40 V

VOUT: 3.3V

IOUT : 0~2A

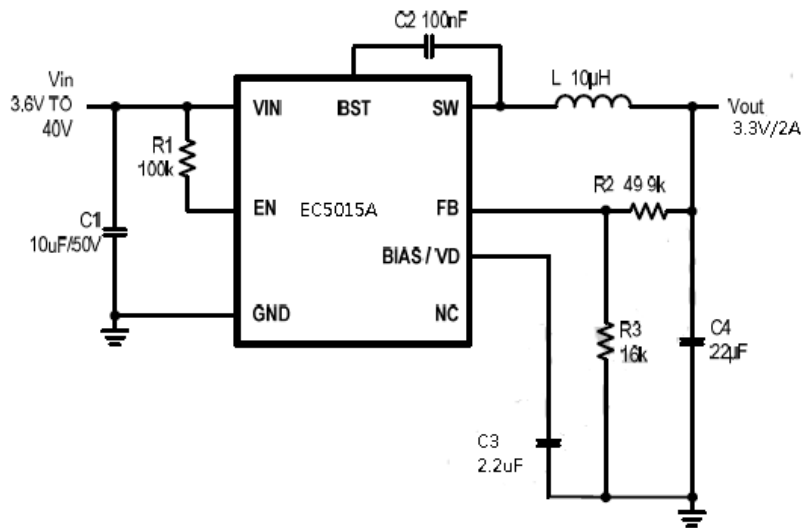

Reference 2 :

VIN : 5.1V ~ 40 V

VOUT: 5V

IOUT : 0~2A

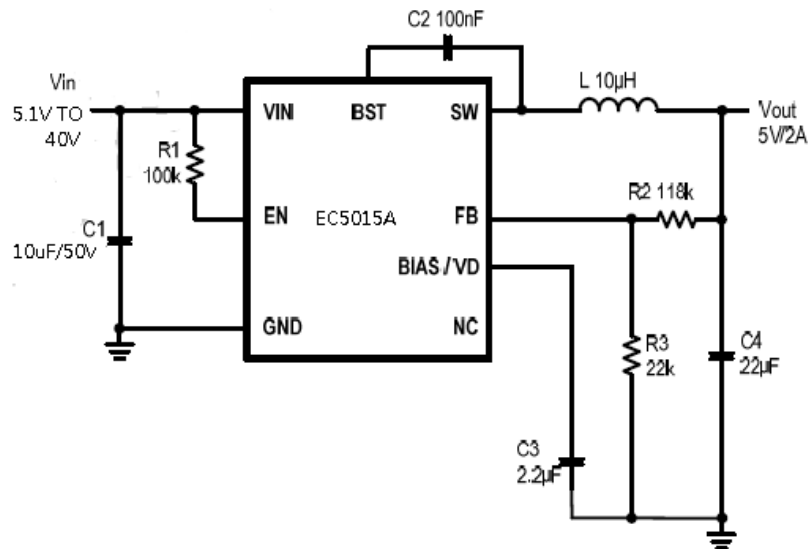

Package Outline

