

General Description

The EJW5017F is a current mode monolithic buck switching regulator. Operating with an input range of 4.5V~26V, The EJW5017F delivers 1.2A of continuous output current with two integrated N-Channel MOSFETs. The EJW5017F operates in fixed 1.2MHz for all load range to prevent low frequency interference. The EJW5017F guarantees robustness with over current protection, thermal protection, start-up current run-away protection, and input under voltage lockout. The EJW5017F is available in 6-pin SOT23-6 package, which provides a compact solution with minimal external components.

Features

- ◆ 4.5 V to 26 V operating input range
- ◆ 1.2A output current
- ◆ Up to 94% efficiency
- ◆ Internal Soft-Start
- ◆ Fixed 1.2MHz Switching frequency
- ◆ Available in SOT23-6 package
- ◆ Input under voltage lockout
- ◆ Start-up current run-away protection
- ◆ Over current protection and Hiccup
- ◆ Thermal protection

Applications

- ◆ Distributed Power Systems
- ◆ Automotive Systems
- ◆ High Voltage Power Conversion
- ◆ Industrial Power Systems
- ◆ Battery Powered Systems

Typical application

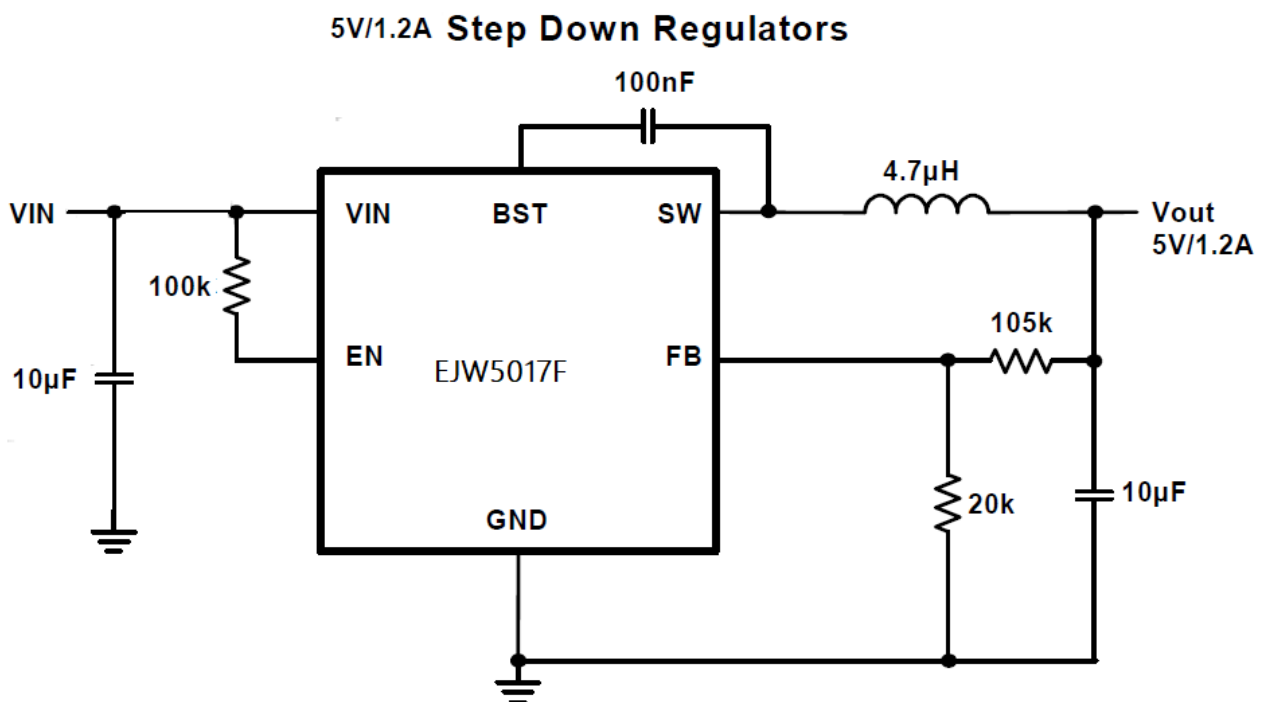

Ordering/Marking Information

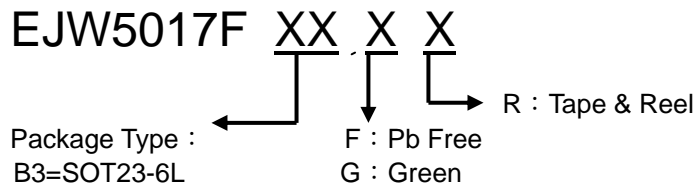

Device	Marking	Package	Mark information
EJW5017FB3XR	JWE6 XXXX	SOT23-6L	XXXX : Date Code

Pin Configurations

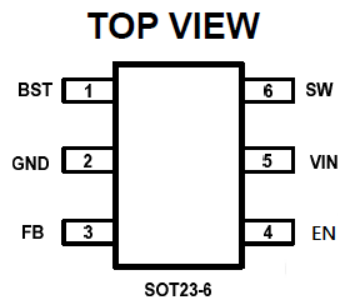

Absolute Maximum Ratings¹

VIN, EN Pin.....	-0.3V to 27V
SW.....	-0.3V(-4V for 5ns) to 27V(28V for 10ns)
BST Pin.....	SW-0.3V to SW+5V
All other Pins.....	-0.3V to 6V
Junction Temperature ^{2) 3)}	150°C
Lead Temperature.....	260°C
Storage Temperature.....	-65°C to +150°C
ESD Susceptibility (Human Body Model)	2kV

Recommended Operating Conditions

Input Voltage VIN.....	4.5Vto 26V
Output Voltage Vout.....	0.8Vto 21V
Operating Junction Temperature.....	-40°Cto 125°C

Thermal Performance⁴

SOT23-6	220...130°C/W
---------------	---------------

Note

- 1) Exceeding these ratings may damage the device.
- 2) The EJW5017F guarantees robust performance from -40°C to 150°C junction temperature. The junction temperature range specification is assured by design, characterization and correlation with statistical process controls.
- 3) The EJW5017F includes thermal protection that is intended to protect the device in overload conditions. Thermal protection is active when junction temperature exceeds the maximum operating junction temperature. Continuous operation over the specified absolute maximum operating junction temperature may damage the device.
- 4) Measured on JESD51-7, 4-layer PCB.



1.2A, 26V Synchronous Step-Down Converter

EJW5017F

Electrical Characteristics

V_{IN} = 12V, T_A = 25°C, unless otherwise stated.

Item	Symbol	Condition	Min.	Typ.	Max.	Units
V _{IN} Under voltage Lockout Threshold	V _{IN_MIN}	V _{IN} falling	4	4.2	4.4	V
V _{IN} Under voltage Lockout Hysteresis ⁵⁾	V _{IN_MIN_HYST}	V _{IN} rising		300		mV
Shutdown Supply Current	I _{SD}	V _{EN} =0V		0.1	1	μA
Supply Current	I _Q	V _{EN} =5V, V _{FB} =1.2V		1.7	2	mA
Feedback Voltage	V _{FB}	4.5V < V _{IN} < 26V	776	800	824	mV
Top Switch Resistance ⁵⁾	R _{DS(ON)T}			300		m
Bottom Switch Resistance ⁵⁾	R _{DS(ON)B}			150		m
Top Switch Leakage Current	I _{LEAK_TOP}	V _{IN} =26V, V _{EN} =0V, V _{SW} =0V			1	uA
Bottom Switch Leakage Current	I _{LEAK_BOT}	V _{IN} = V _{SW} = 26V, V _{EN} =0V			1	uA
Top Switch Current Limit ⁵⁾	I _{LIM_TOP}	Minimum Duty Cycle		2		A
Switch Frequency	f _{SW}		1.0	1.2	1.4	MHz
Minimum On Time ⁵⁾	T _{ON_MIN}			80		ns
Minimum Off Time ⁵⁾	T _{OFF_MIN}	V _{FB} =0.6V		120		ns
EN Shutdown Threshold	V _{EN_TH}	V _{EN} falling, FB=0V	1.2	1.3	1.4	V
EN Shutdown Hysteresis ⁵⁾	V _{EN_HYST}	V _{EN} rising, FB=0V		100		mV
Thermal Shutdown ⁵⁾	T _{TSD}			150		°C
Thermal Shutdown hysteresis ⁵⁾	T _{TSD_HYST}			15		°C

Note :

5) Guaranteed by design.

Pin Description

Pin	Name	Description
1	BST	Bootstrap pin for top switch. A 0.1uF or larger capacitor should be connected between this pin and the SW pin to supply current to the top switch and top switch driver.
2	GND	Ground.
3	FB	Output feedback pin. FB senses the output voltage and is regulated by the control loop to 800mV. Connect a resistive divider at FB.
4	EN	Drive EN pin high to turn on the regulator and low to turn off the regulator.
7	VIN	Input voltage pin. VIN supplies power to the IC. Connect a 4.5V to 26V supply to VIN and bypass VIN to GND with a suitably large capacitor to eliminate noise on the input to the IC.
8	SW	SW is the switching node that supplies power to the output. Connect the output LC filter from SW to the output load.

Block Diagram

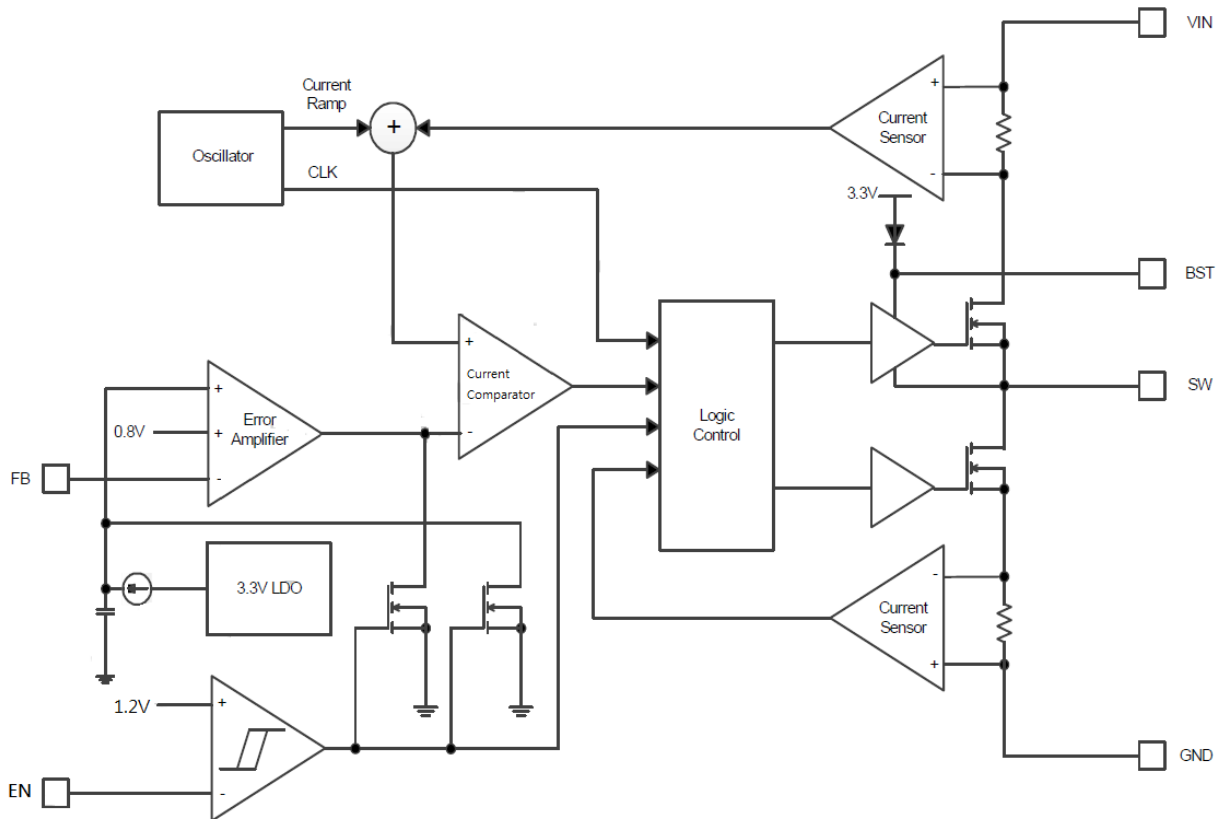

Typical Performance Characteristics

$V_{in} = 12V$, $V_{out} = 3.3V$, $L = 4.7\mu H$, $C_{out} = 10\mu F$, $T_A = +25^\circ C$, unless otherwise noted

Steady State Test

$V_{IN}=12V$, $V_{out}=3.3V$
 $I_{out}=1.2A$

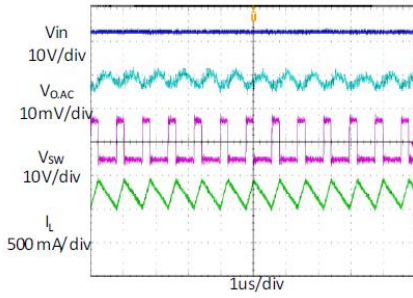

Startup through Enable

$V_{IN}=12V$, $V_{out}=3.3V$
 $I_{out}=1.2A$ (Resistive load)

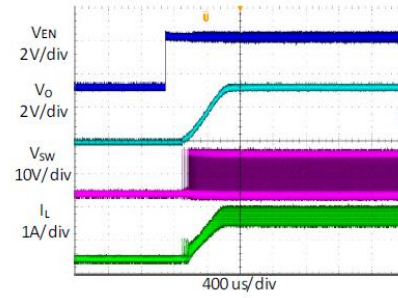

Shutdown through Enable

$V_{IN}=12V$, $V_{out}=3.3V$
 $I_{out}=1.2A$ (Resistive load)

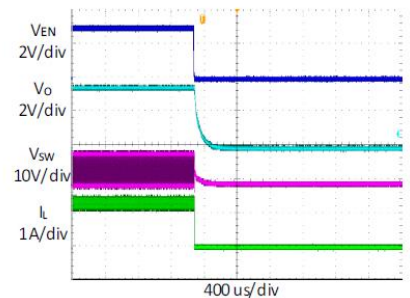

Heavy Load Operation

1.2A LOAD

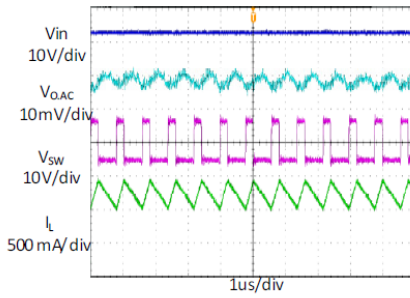

Medium Load Operation

0.6A LOAD

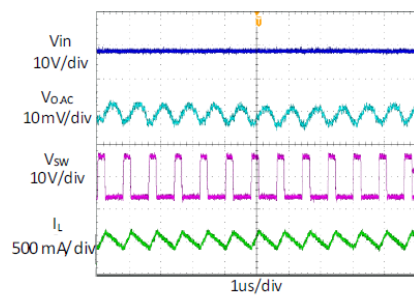

Light Load Operation

0 A LOAD

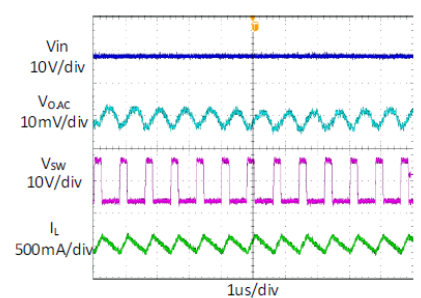

Short Circuit Protection

$V_{IN}=12V$, $V_{out}=3.3V$
 $I_{out}=1.2A$ - Short

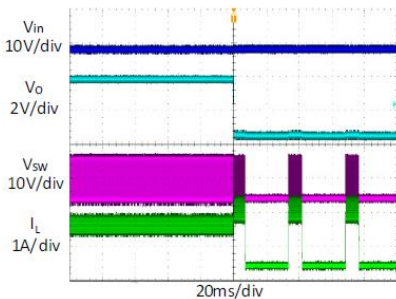

Short Circuit Protection

$V_{IN}=12V$, $V_{out}=3.3V$
 $I_{out}=$ Short -1.2A

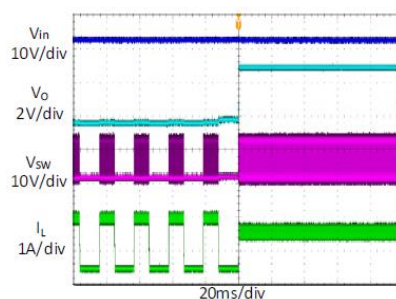

Load Transient

0.6A LOAD \rightarrow 1.2A LOAD \rightarrow 0.6A LOAD

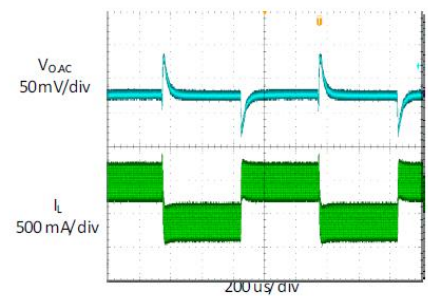

Typical Performance Characteristics (continued)

Vin = 12V, Vout = 3.3V, L = 4.7μH, Cout = 10μF, TA = +25°C, unless otherwise noted

Load regulation @ Vout=3.3V

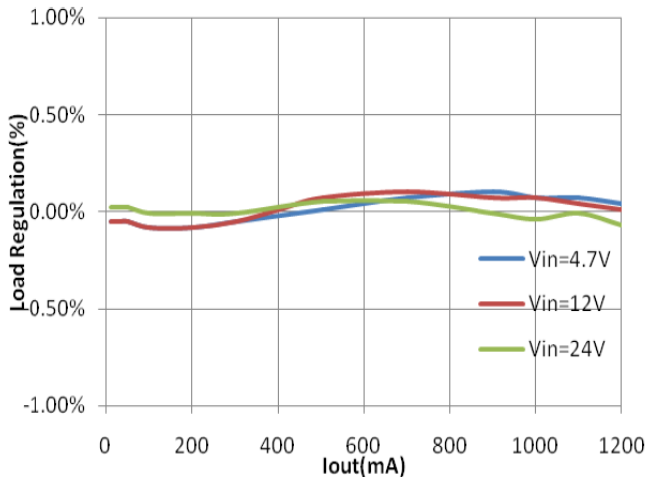

Shutdown Current Vs. Input Voltage

VIN=4.5V ~ 26V, VEN=0V

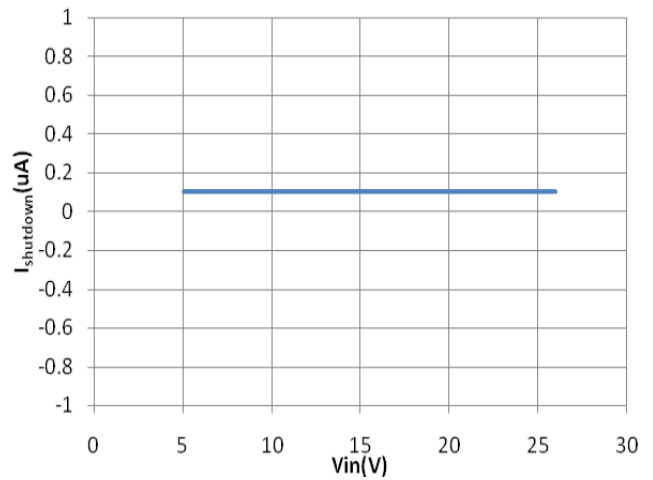

Efficiency @ Vout=3.3V

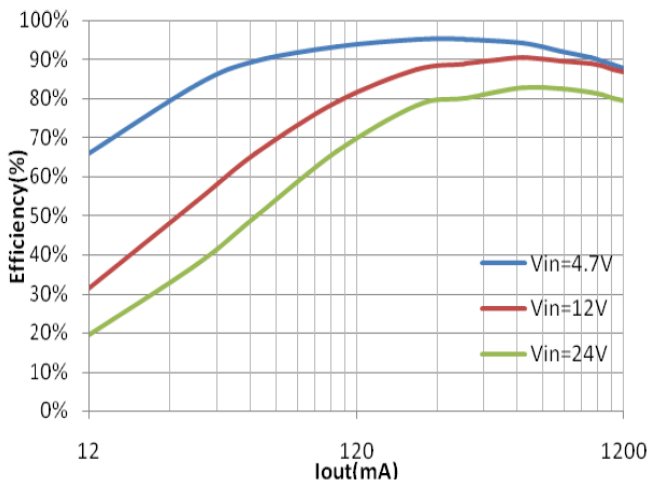

Efficiency @ Vout=5V

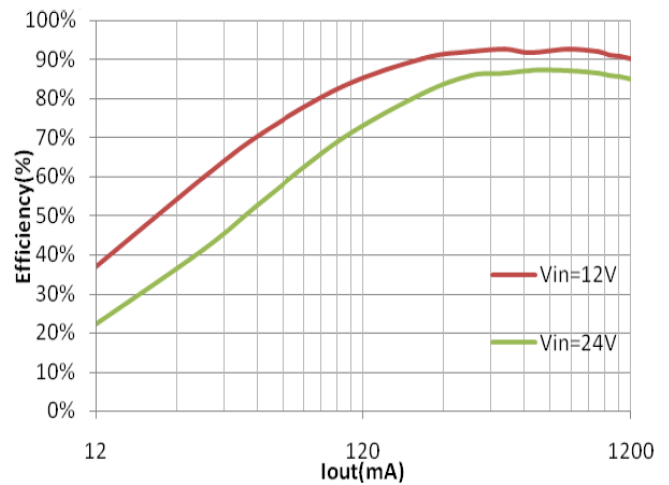

Current Limit

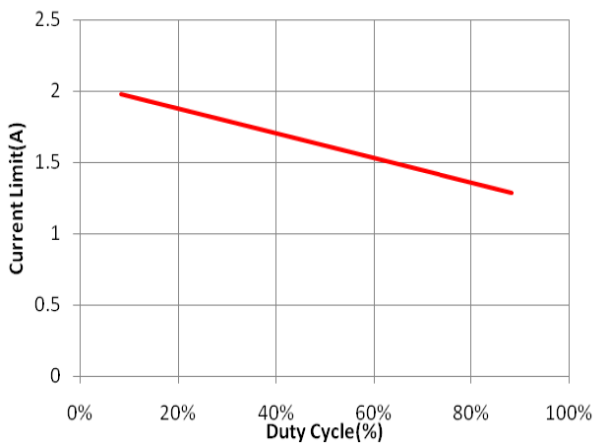

Functional Description

The EJW5017F is a synchronous, current-mode, step-down regulator. It regulates input voltage from 4.5V to 26V down to an output voltage as low as 0.8V, and is capable of supplying up to 1.2A of load current.

Current-Mode Control

The EJW5017F utilizes current-mode control to regulate the output voltage. The output voltage is measured at the FB pin through a resistive voltage divider and the error is amplified by the internal trans conductance error amplifier. Output of

The internal error amplifier is compared with the switch current measured internally to control the output current limit.

Shut-Down Mode

The EJW5017F operates in shut-down mode when voltage at EN pin is driven below 0.3V. In shut-down mode, the entire regulator is off and the supply current consumed by the EJW5017F drops below 0.1uA.

Power Switch

N-Channel MOSFET switches are integrated on the EJW5017F to down convert the input voltage to the regulated output voltage. Since the top MOSFET needs a gate voltage greater than the input voltage, a boost capacitor connected between BST and SW pins is required to drive the gate of the top switch. The boost capacitor is charged by the internal 3.3V rail when SW is low.

Vin Under-Voltage Protection

A resistive divider can be connected between Vin and ground, with the central tap connected to EN, so that when Vin drops to the pre-set value, EN drops below 1.2V to trigger input under voltage lockout protection.

Output Current Run-Away Protection

At start-up, due to the high voltage at input and low voltage at output, current inertia of the output inductance can be easily built up, resulting in a large start-up output current. A valley current limit is designed in the EJW5017F

so that only when output current drops below the valley current limit can the bottom power switch be turned off. By such control mechanism, the output current at start-up is well controlled.

Over Current Protection and Hiccup

EJW5017F has a cycle-by-cycle current limit. When the inductor current triggers current limit, EJW5017F enters hiccup mode and periodically restart the chip. EJW5017F will exit hiccup mode while not triggering current limit.

Thermal Protection

When the temperature of the EJW5017F rises above 140°C, it is forced into thermal shut-down. Only when core temperature drops below 125°C can the regulator becomes active again.

Application Information

Output Voltage Set

The output voltage is determined by the resistor divider connected at the FB pin, and the voltage ratio is:

$$V_{FB} = V_{OUT} \frac{R_2}{R_2 + R_3}$$

where VFB is the feedback voltage and VOUT is the output voltage. Choose R2 around 20k , and then R3 can be calculated by:

$$R_3 = R_2 \cdot \left(\frac{V_{OUT}}{0.8V} - 1 \right)$$

The following table lists the recommended values.

VOUT(V)	R2(K ω)	R3(K ω)
2.5	22.1	47
3.3	16	49.9
5	20	105

Input Capacitor

The input capacitor is used to supply the AC input current to the step-down converter and maintaining the DC input voltage. The ripple current through the input capacitor can be calculated by:

$$I_{C1} = I_{LOAD} \cdot \sqrt{\frac{V_{OUT}}{V_{IN}} \cdot \left(1 - \frac{V_{OUT}}{V_{IN}}\right)}$$

where I_{LOAD} is the load current, V_{OUT} is the output voltage, V_{IN} is the input voltage.

Thus the input capacitor can be calculated by the following equation when the input ripple voltage is determined.

$$C_1 = \frac{I_{LOAD}}{f_s \cdot \Delta V_{IN}} \cdot \frac{V_{OUT}}{V_{IN}} \cdot \left(1 - \frac{V_{OUT}}{V_{IN}}\right)$$

where C₁ is the input capacitance value, f_s is the switching frequency, V_{IN} is the input ripple voltage.

The input capacitor can be electrolytic, tantalum or ceramic. To minimizing the potential noise, a small X5R or X7R ceramic capacitor, i.e. 0.1Uf, should be placed as close to the IC as possible when using electrolytic capacitors.

A 10Uf ceramic capacitor is recommended in typical application.

Output Capacitor

The output capacitor is required to maintain the DC output voltage, and the capacitance value determines the output ripple voltage. The output voltage ripple can be calculated by:

$$\Delta V_{OUT} = \frac{V_{OUT}}{f_s \cdot L} \cdot \left(1 - \frac{V_{OUT}}{V_{IN}}\right) \cdot \left(R_{ESR} + \frac{1}{8 \cdot f_s \cdot C_2}\right)$$

where C₂ is the output capacitance value and RESR is the equivalent series resistance value of the output capacitor.

The output capacitor can be low ESR electrolytic, tantalum or ceramic, which lower ESR capacitors get lower output ripple voltage.

The output capacitors also affect the system stability and transient response, and a 10Uf ceramic capacitor is recommended in typical application.

Inductor

The inductor is used to supply constant current to the output load, and the value determines the ripple current which affect the efficiency and the output voltage ripple. The ripple current is typically allowed to be 40% of the maximum switch current limit, thus the inductance value can be calculated by:

$$L = \frac{V_{OUT}}{f_s \cdot \Delta I_L} \cdot \left(1 - \frac{V_{OUT}}{V_{IN}}\right)$$

where V_{IN} is the input voltage, V_{OUT} is the output voltage, f_s is the switching frequency, and ΔI_L is the peak-to-peak inductor ripple current.

External Bootstrap Capacitor

A bootstrap capacitor is required to supply voltage to the top switch driver. A 0.1uF low ESR ceramic capacitor is recommended to be connected to the BST pin and SW pin.

PCB Layout Note

For minimum noise problem and best operating performance, the PCB is preferred to following the guidelines as reference.

1. Place the input decoupling capacitor as close to EJW5017F(VIN pin and PGND) as possible to eliminate noise at the input pin. The loop area formed by input capacitor and GND must be minimized.
2. Put the feedback trace as far away from the inductor and noisy power traces as possible.
3. The ground plane on the PCB should be as large as possible for better heat dissipation

Reference Design

Reference 1 :

V_{IN} : 4.7V ~ 26V
 V_{OUT} : 3.3V
 I_{OUT} : 0~1.2A

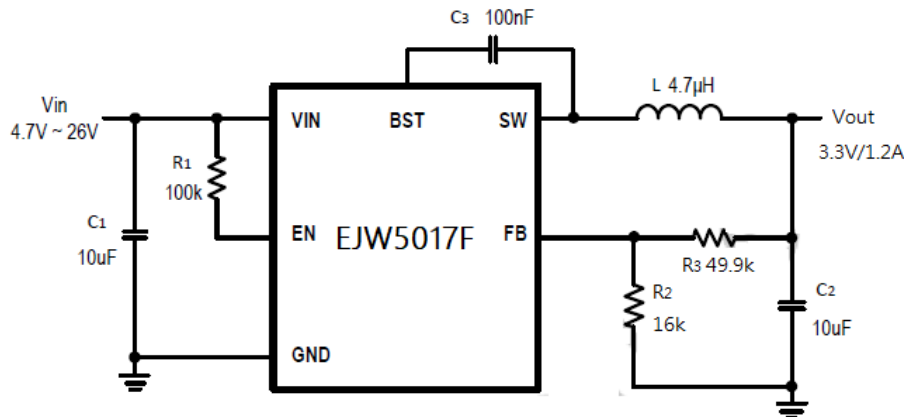

Reference 2 :

V_{IN} : 7V ~ 26V
 V_{OUT} : 5V
 I_{OUT} : 0~1.2A

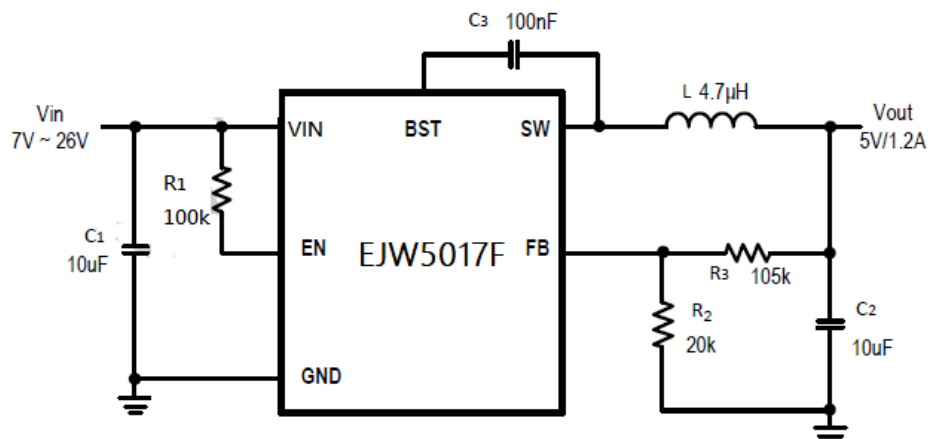

Package Outline

