

### General Description

EC1469 is a 800mA synchronous buck converter with integrated power MOSFETs. The EC1469 design with a current-mode control scheme, can convert wide input voltage of 7V to 40V to the output voltage adjustable from 0.8V to 90%VIN to provide excellent output voltage regulation.

The EC1469 equipped with Power-on-reset, soft start and whole protections (under-voltage, over temperature and current-limit) into a single package.

This device, available SOT-23-6 provides a very compact system solution of external components and PCB area.

Output current(mA)

### Features

- ◆ Wide Input Voltage from 7V to 40V
- ◆ 800mA Output Current
- ◆ High Efficiency over 85% from Load Current 50mA to 100mA @  $V_{OUT} \geq 5V$
- ◆ Low EMI Converter
- ◆ Adjustable Output Voltage from 0.8V to 90%VIN
- ◆ Integrated High/Low Side MOSFET
- ◆ 1M Switching Frequency
- ◆ Stable with Low ESR Capacitors
- ◆ Power-On-Reset Detection
- ◆ Over-Temperature Protection
- ◆ Current-Limit Protection
- ◆ Enable/Shutdown Function
- ◆ Available in SOT-23-6 packages
- ◆ Lead Free and Green Devices Available (RoHS compliant).

### Applications

- ◆ Smart Electronic equipments

### Package Type

SOT23-6

### Pin Configurations

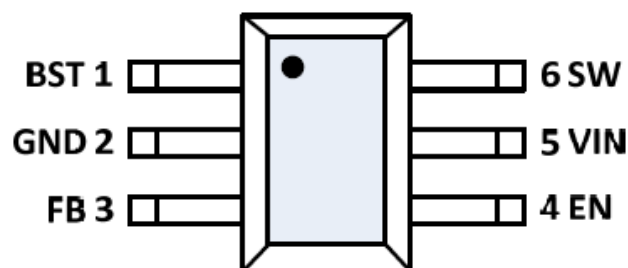

(Top view)



### Pin Description

Pin Number	Pin Name	Description
1	BS	High-Side Gate Drive Boost Input. BS supplies the voltage to drive the high-side N-channel MOSFET. At least 10nF capacitor should be connected from SW to BS to supply the high side switch.
2	GDN	Signal and power ground.
3	FB	Output feedback Input. The EC1469 senses the feedback voltage via FB and regulates the voltage at 0.8V. Connecting FB with a resistor-divider from the converter's output sets the output voltage from 0.8V to 90%VIN.
4	EN	Enable Input. EN is a digital input that turns the regulator on or off. EN threshold is 1.1V with 0.2V hysteresis. Pull up with 1MΩ resistor for automatic startup.
5	VIN	Power Input. VIN supplies the power (7V to 40V) to the control circuitry, gate drivers and step-down converter switches. Connecting a ceramic bypass capacitor and a suitably large capacitor between VIN and GND eliminates switching noise and voltage ripple on the input to the IC.
6	SW	Power Switching Output. It is the Drain of the N-Channel power MOSFET to supply power to the output LC filter.

### Ordering Information

EC1469 XX X X

R : Tape & Reel

Package Type :  
B3 : SOT23-6

G : Green

### Function Block

Figure1 Function Block Diagram of EC1469



### Absolute Maximum Ratings (Note1)

Symbol	Parameter	Rating	Unit
V <sub>IN</sub>	VIN Supply Voltage (VIN to Gnd)	-0.3 ~ 43	V
V <sub>SW</sub>	SW to GND Voltage	-0.3 to V <sub>IN</sub> +0.3	V
V <sub>BS</sub>	BS to GND Voltage	V <sub>SW</sub> - 0.3 ~ V <sub>SW</sub> +6	V
	All Other Pins	-0.3 ~ 6	V
P <sub>D</sub>	Power Dissipation	Internally Limited	W
T <sub>J</sub>	Junction Temperature	150	°C
T <sub>STG</sub>	Storage Temperature	-65 ~ 150	°C
T <sub>SDR</sub>	Maximum Lead Soldering Temperature (10 Seconds)	260	°C

Note1: Stresses beyond those listed under "absolute maximum ratings" may cause permanent damage to the device. These are stress ratings only and functional operation of the device at these or any other conditions beyond those indicated under "recommended operating conditions" is not implied. Exposure to absolute maximum rating conditions for extended periods may affect device reliability.

### Thermal Characteristics

Symbol	Parameter	Typical Value	Unit
θ <sub>JA</sub>	Junction-to-Ambient Resistance in free air <sup>(Note 2)</sup> SOT-23-6	250	°C/W

Note 2:

θ<sub>JA</sub> is measured with the component mounted on a high effective thermal conductivity test board in free air.

### Recommended Operation Conditions

Symbol	Parameter	Range	Unit
V <sub>IN</sub>	VIN Supply Voltage	7~40	V
V <sub>OUT</sub>	Converter Output Voltage	V <sub>FB</sub> ~ V <sub>IN</sub> *90%	V
	Operating Junction Temp	-40 ~ 125	°C

Note 3:

Refer to the typical application circuit



# 40V, 800mA, 1MHz synchronous Buck Converter

EC1469

## Electrical Characteristics

Unless otherwise specified, these specifications apply over  $V_{IN}=12V$ ,  $V_{EN}=3V$  and  $T_A = 25^{\circ}C$ .

Symbol	Parameter	Test Conditions	Min	Typ	Max	Unit
$V_{FB}$	Feedback Voltage	$10V \leq V_{IN} \leq 60V$	0.792	0.812	0.832	V
$I_{FB}$	Feedback Current	$V_{FB} = 0.85V$	-	-	0.1	$\mu A$
$R_{DS(ON)}$	High Side MOSFET Resistance		-	0.9	-	$\Omega$
	Low Side MOSFET Resistance		-	0.4	-	$\Omega$
$I_{SW\_LKG}$	Switch Leakage	$V_{EN}=0V, V_{SW}=0V$	-	-	1	$\mu A$
$I_{LIM}$	Current Limit		-	1	-	A
$f_{SW}$	Oscillator Frequency	$V_{FB}=0.6V$	0.8	1	1.2	MHz
$f_{SW\_F}$	Foldback Frequency	$V_{FB}=0V$	-	125	-	KHz
$D_{MAX}$	Maximum Duty Cycle	$V_{FB}=0.6V$	-	90	-	%
$T_{ON}$	Minimum ON-Time		-	100	-	ns
$V_{UVLO\_R}$	Under-Voltage Lockout Threshold, Rising		-	6	-	V
$V_{UVLO\_F}$	Under-Voltage Lockout Threshold, Falling		-	5.5	-	V
$V_{UVLO\_HYS}$	Under-Voltage Lockout Threshold, Hysteresis		-	0.5	-	V
$t_{SS}$	Soft Start Time		-	1	-	ms
$V_{EN\_R}$	EN Threshold, Rising		-	1.1	-	V
$V_{EN\_F}$	EN Threshold, Falling		-	0.9	-	V
$V_{EN\_HYS}$	EN Threshold, Hysteresis		-	200	-	mv
$I_{EN}$	EN Input Current	$V_{EN}=2V$	-	3.1	-	$\mu A$
		$V_{EN}=0V$	-	0.1	-	$\mu A$
$I_S$	Supply Current (Shutdown)	$V_{EN}=0V$	-	0.1	1	$\mu A$
$I_Q$	Supply Current (Quiescent)	$V_{EN}=2V, V_{FB}=1V$	-	0.73	0.85	mA
$T_{SD}$	Thermal Shutdown		-	165	-	$^{\circ}C$
$T_{SD\_HYS}$	Thermal Shutdown Hysteresis		-	20	-	$^{\circ}C$

### Typical Operating Characteristics

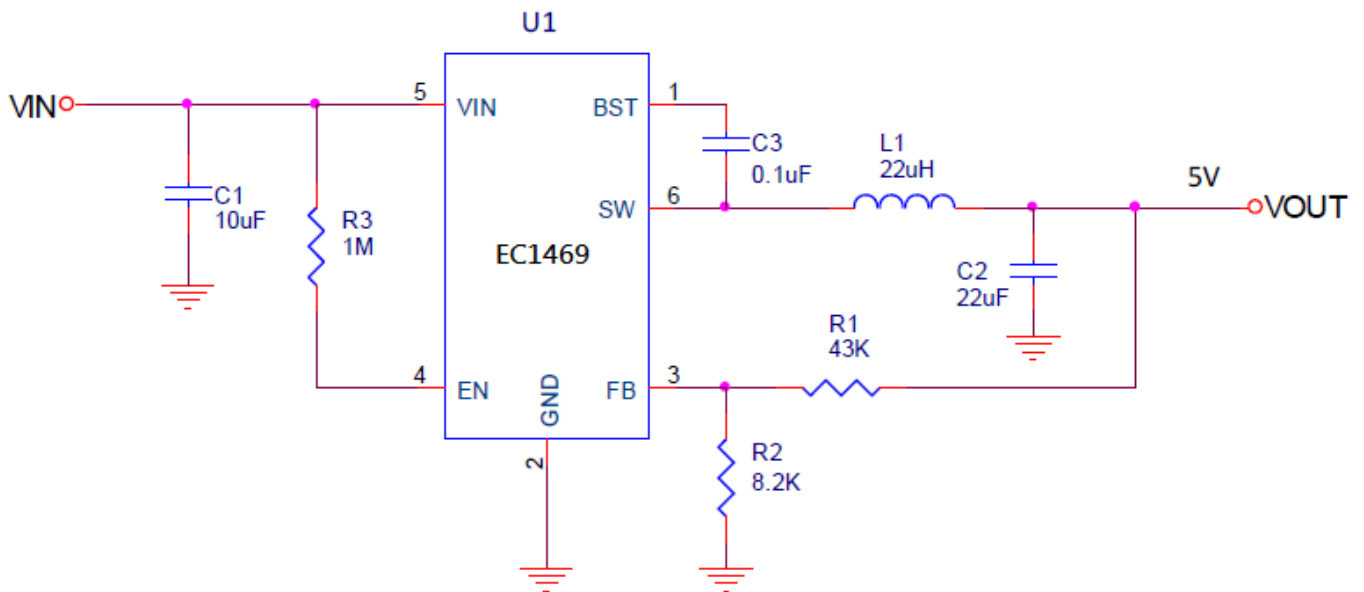

$$V_{OUT} = V_{REF} \left( 1 + \frac{R1}{R2} \right)$$



### Application Information

#### Main Control Loop

The EC1469 is a constant frequency, synchronous rectifier and current-mode switching regulator. In normal operation, the internal upper power MOSFET is turned on each cycle. The peak inductor current at which ICMP turn off the upper MOSFET is controlled by the voltage on the COMP node, which is the output of the error amplifier(EAMP). An external resistive divider connected between Vout and ground allows the EAMP to receive an output feedback voltage VFB at FB pin. When the load current increases, it causes a slightly decrease in VFB relative to the 0.8V reference, which in turn causes the COMP voltage to increase until the average inductor current matches the new load current.

#### VIN Power-On-Reset (POR)

The EC1469 keep monitoring the voltage on VIN pin to prevent wrong logic operations which may occur when VIN voltage is not high enough for the internal control circuitry to operate. The VIN POR has a rising threshold of 6V (typical) with 0.5V of hysteresis. After the VIN voltages exceed its respective POR thresholds, the IC starts a start-up process and then ramps up the output voltage to the setting of output voltage. Connect a RC network from EN to GND to set a turn-on delay that can be used to sequence the output voltages of multiple devices.

#### Enable/Shutdown

Driving EN to ground places the EC1469 in shutdown. When in shutdown, the internal power MOSFETes turn off, all internal circuitry shuts down and the quiescent supply current of VIN reduces to <10μA, the EN undervoltage- lockout (UVLO) has a rising threshold of 1.4V(typical) with 0.2V of hysteresis.

#### Soft-Start

The EC1469 provides built-in soft-start function to limit the inrush current. The soft-start time is 1ms °

#### Setting Output Voltage

The regulated output voltage is determined by:  $V_{OUT} = 0.8 \times \left(1 + \frac{R_1}{R_2}\right)$

To prevent stray pickup, please locate resistors R1 and R2 close to EC1469.

#### Bootstrap Capacitor

The EC1469 is a N-channel MOSFET step down converter. The MOSFET requires a gate voltage that is higher than input voltage, thus a boost capacitor should be connected between SW and BST pins to drive the gate of the N-channel MOSFET. Typical bootstrap capacitor value is from 10nF to 100nF.

#### Over-Current-Protection and Hiccup

The EC1469 has a cycle-by-cycle over-current limit when the inductor current peak value exceeds the set current limit threshold. Meanwhile, the output voltage drops until FB is below the Under-Voltage (UV) threshold below the reference. Once UV is triggered, the EC1469 enters hiccup mode to periodically restart the part. This protection mode is especially useful when the output is dead-shortened to ground. The average short circuit current is greatly reduced to alleviate thermal issues and to protect the regulator. The EC1469 exits the hiccup mode once the over-current condition is removed.

#### Over-Temperature Protection (OTP)

The over-temperature circuit limits the junction temperature of the EC1469. When the junction temperature exceeds 150°C, a thermal sensor turns off the N-channel power MOSFET, allowing the device to cool down. The thermal sensor allows the converter to start a start-up process and regulate the output voltage again after the junction temperature cools by 30°C. The OTP designed with a 30°C hysteresis lowers the average TJ during continuous thermal overload conditions, increasing life time of the EC1469.

### Package Information

SOT23-6 Package Outline Dimensions