

General Description

EC1742-2COT is a DC/DC Buck Controller with 2 current sense pins suitable for many multi-output applications. It is designed to allow for operating a wide supply voltage range from 7.5V to 40V. It has both high-side and low-side drivers allowing synchronous configuration using two external power-NMOS. This IC can operate in both Constant Current (CC) and Constant Voltage (CV) modes. EC1742-2COT operates as a DC/DC Buck Controller providing a wide range of outputs at Constant Voltage (CV) from 1.23V to 28V and the output current as high as 10A or above. It has a Constant Current(CC) mode so that output current can be set externally and at a accuracy of +/- 7%. The current mode control makes feedback control have good line and load regulation with flexible external design. There are 2 independent current limit control pins in addition to the CC setting for added flexibility of driving 2 separate loads. Each of the current limits can be set by a sense resistor at 100mV across it. Of course, output peak current limit is working during normal operation..

Features

- ◆Vin: 7.5V to 40V
- ◆Vout: 3V to 28V; typical at 5V
- ◆CC/CV Mode Control
- ◆Burst/PFM Mode for Increased Light Load Efficiency
- ◆Hiccup mode 1-2S when SCP/OVP occur
- ◆Protection
 - NMOS peak current limit: accuracy : ~20%
 - Output short protection: reduce input current to less than 20mA(RMS)
 - OVP(output Over-Voltage Protection)
 - Output FB short protection
 - Temperature shut down(OTP).
- ◆Adjustable Output Cable Resistance Compensation
- ◆Duty: 0~98%(Toff_min=100ns, Deadtime=25~35ns)
- ◆Switching Frequency: 150KHz(+/- 25k)
- ◆Integrated MOSFET Driver.
- ◆OVP: When $V_{fb} > 120\% \cdot V_{REF}$, open discharge switch (Vout1/2). Discharge current > 50mA
- ◆QFN- 16 Package

Applications

- ◆Car Charger
- ◆High-Brightness Lighting
- ◆General-Purpose DC/DC Application

Pin Configurations

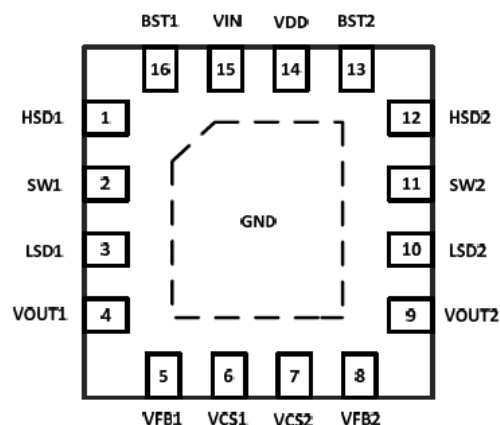

Figure1 Pin Configuration of EC1742(Top View)



40Vin 2 Outputs COT Buck Controller

EC1742

Pin Description

Pin Number	Pin Name	Description
1	HSD1	High Side Driver
2	SW1	Inductor terminal.
3	LSD1	Low Side Driver
4	VOUT1	VOUT1 feedback
5	VFB1	Feedback input with reference to 1.20V. It can set output voltage.
6	VCS1	Current sense positive pin.
7	VCS2	Current sense negative pin.
8	VFB2	Feedback input with reference to 1.20V. It can set output voltage.
9	VOUT2	VOUT2 feedback
10	LSD2	Low Side Driver
11	SW2	Inductor terminal.
12	HSD2	High Side Driver
13	BST2	Internal High Side Driver Power Bias which is typically 5V above Vin. A typical 0.1uF capacitor is used connecting between BST and SW pins.
14	VDD	Internal 5v power supply, a 1uF (or more) capacitor is connected between this pin and GND.
15	VIN	Supply input
16	BST1	Internal High Side Driver Power Bias which is typically 5V above Vin. A typical 0.1uF capacitor is used connecting between BST and SW pins.
	GND	Ground pin.

Ordering/Marking Information

EC1742NN XX X

R : Tape & Reel

Package Type :
Q2 : QFN16L

Part Number	Package	Marking	Marking Information
EC1742NNQ2R	QFN16L	EC1742N LLLLL YYWW	LLLLL is Lot Number YYWW is date code

Function Block

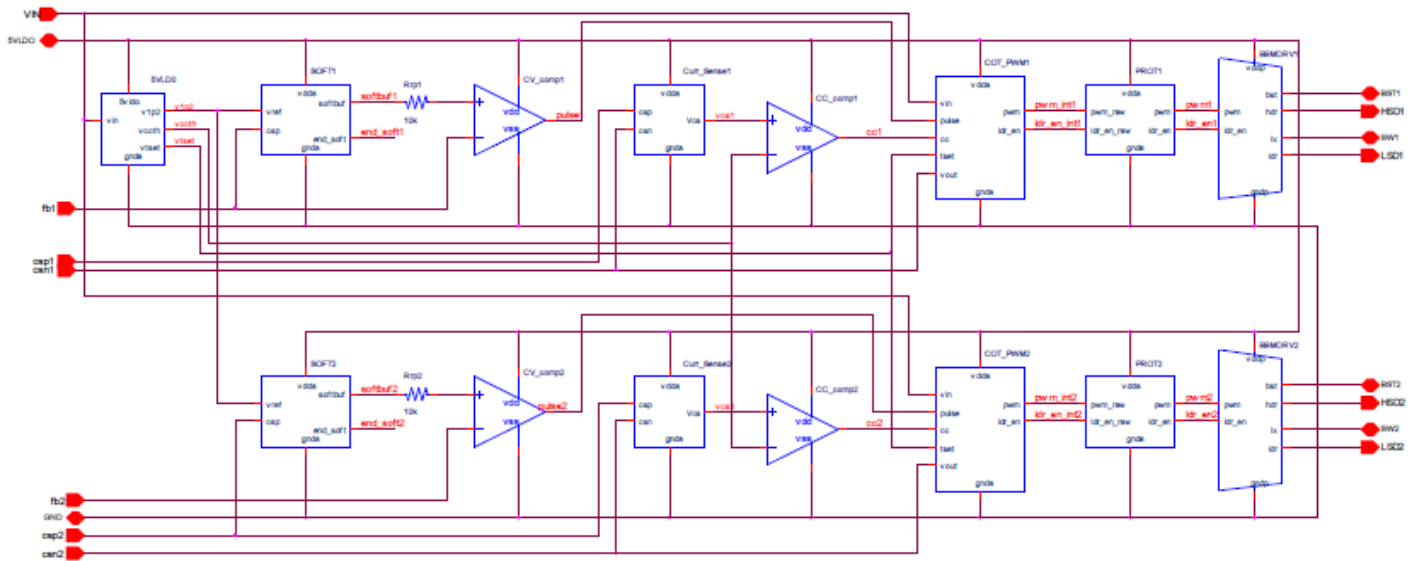

Figure 2 Function Block Diagram of EC1742

Absolute Maximum Ratings

Symbol	Parameter	Rating	Unit
VIN	Supply Input Voltage	-0.3 to +43	V
	SW to GND	-1 to VIN+1	V
	BST,HSD to SW	VSW-0.3toVSW+6	V
	VDD,VFB1-2,LSD1-2 to GND	-0.3 to +6	V
	VCS1-2 to GND	-0.3 to +0.3	V
ESD	HBM (Human Body Mode)	2K	V
θJA	Thermal Resistance from Junction to ambient	40	°C/W

Recommended Operating Conditions

Symbol	Parameter	Rating			Unit
		Min.	Typ.	Max.	
VIN	Supply Voltage	7.5	-	40	V
VOUT	Output voltage range	3	-	28	V
IOUT	Output current range	-	-	15	A
TOP	Operating Temperature	-40	-	85	°C
TSTG	Storage Temperature Range	-65	-	150	°C
TJ	Junction Temperature	-40	-	150	°C
TSDR	Maximum Lead Soldering Temperature, 10 Seconds	260			°C



40Vin 2 Outputs COT Buck Controller

EC1742

Electrical Characteristics

V_{IN}=12V, T_A=25°C (unless otherwise specified). MOSFET use TDM3436)

Symbol	Characteristic	Test conditions	Min	Typ	Max	Unit
V _{IN}	Supply Voltage		7.5	-	40	V
I _{IN}	Supply Input Current	V _{out} =5V, No load	0.6	0.8	2.5	mA
VIN UVLO						
V _{UP}	VIN UVLO Turn ON	VIN Rising	5.0	5.5	6.0	V
V _{HYS}	VIN UVLO Hysteresis	VIN Falling	-	1.0	-	V
Feedback voltage						
V _{FB1/2}	Feedback voltage		1.176	1.20	1.224	V
	Tolerance		-2	-	2	%
Soft Start						
	Soft Start time		-	0.7	-	ms
Oscillator						
F _{SW}	Switch frequency		125	150	175	KHz
T _{ON}	Minimum On-Time		-	150	-	ns
D	Duty cycle		-	-	98	%
Current sense						
V _{CC1}	CC threshold		46.5	50	53.5	mV
V _{CC2}	CC threshold	V _{OUT} =5V	41	44	47	mV
I _{FB}	Cable compensation Current	V _{in} =12V, C _{out1-2} =40mv	-	4.0	-	uA
HDR & LDR Drivers						
T _{RH}	HDR Rising Time		-	10	-	ns
T _{FH}	HDR Falling Time		-	10	-	ns
T _{RL}	LDR Rising Time		-	10	-	ns
T _{FL}	LDR Falling Time		-	10	-	ns
T _{LH}	Dead Time		-	30	-	ns
T _{HL}	Dead Time		-	30	-	ns
Thermal Shutdown(OTP)						
T _{SD}	Temperature Rising		-	150	-	°C
T _{HYS}	OTP Hysteresis		-	20	-	°C

Typical Application Circuit

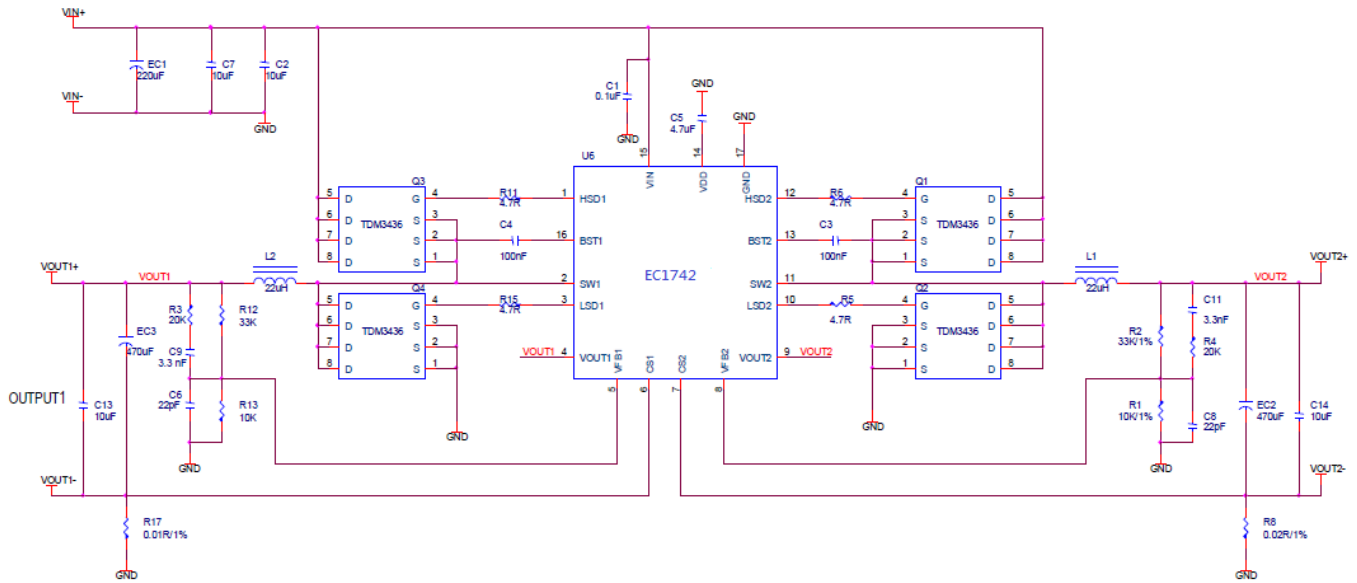

Figure 3 2-outputs with CC

Function Description

EC1742 operates in a constant on time control to regulate the output voltage. When the feedback voltage FB lower than the VREF, turns on the high side power MOSFET. Ton calculator decides the high-side MOSFET on time. When the power switch is off, it remains off until the FB lower than VREF.

CC/CV Mode Control

EC1742 provides CC/CV function. The Constant output Current control Mode and Constant output Voltage control Mode.

Output Voltage Setting

VFB is the feedback pin and connected to the non-inverting of error amplifier input. The output voltage is adjustable from 3V to 28V with a resistor-divider connected with VFB GND and converter's output. Using 1% or better resistors for the resistor-divider is recommended. The output voltage is determined by the equation:

$$V_{OUT} = V_{FB} * (1 + R1/R2) = 1.2V * (1 + R1/R2)$$

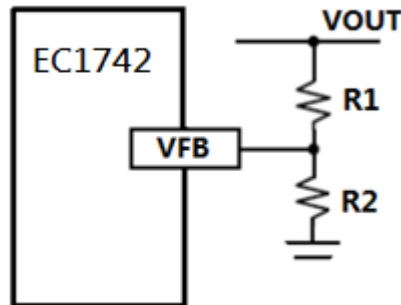

R1 can program the cable compensation.

Constant Current setting

Adjust the sense resistor (Rs) can set the constant current value. $I_{CC} = 0.05/R_s$

Output Cable Resistance Compensation

To compensate for resistive voltage drop across the charger's output cable, the integrates a simple, user programmable cable voltage drop compensation using the impedance at the FB pin. By choosing different R1, we can get different cable voltage drop compensation values. $V_c = R1 * V_{cs} * 9/100000$

FB UVP

For EC1742, Hiccup Mode of Under Voltage Protection (UVP) is provided. If cc mode is triggered or over short current protection (SCP) occur, the output voltage will be pulled down quickly. When $FB < 50% * V_{FB}$, the controller will enter hiccup mode by disabling the converter and restarts soft-start after a predefined interval about 4s until the under voltage condition is removed.

Over Temperature Protection (OTP)

EC1742 provides over temperature protection (OTP). The OTP will shut down the converter when junction temperature exceeds 150°C. Once the junction temperature cools down by approximately 30°C, the controller will resume.

Output Inductor Selection

The inductor value (L) determines the inductor ripple current, IRIPPLE and affects the load transient response. Higher inductor value reduces the inductor's ripple current and induces lower output ripple voltage. The ripple current and ripple voltage can be approximated by: $L = V_{OUT} * (V_{IN} - V_{OUT}) / F_{SW} * I_{RIPPLE} * V_{IN}$

Where FSW : the switching frequency of the regulator; VIN/VOUT : input voltage/output voltage; IRIPPLE is the inductor ripple current and $I_{RIPPLE} = (0.3 - 0.5) I_{OUT}$

Input Capacitor

A low ESR capacitor is highly recommended. Since large current flows in and out of this capacitor during switching, its ESR also affects efficiency. The input capacitance should be higher than 22μF. The best choice is the ceramic type, however, low ESR tantalum or electrolytic types may also be used. The input capacitor should be placed close to the VIN and GND pins of the IC, with the shortest traces possible. In the case of tantalum or electrolytic types, they can be further away if a small parallel 1μF ceramic capacitor is placed right next to the IC.

Output Capacitor

The system requires the output capacitor to maintain the dc output voltage. The characteristics of the output capacitor affect the stability of the regulatory system. A low ESR electrolytic capacitor is recommended for a low output ripple and good control loop stability. For general applications, a 10μF ceramic capacitor and a 470μF (or more) polymer/electrolytic capacitor are recommended.



40Vin 2 Outputs COT Buck Controller

EC1742

Package Information

QFN16L Package Package Outline Dimensions

Symbol	A	A1	b	c	D	D2	e	Ne	Nd	E	E2	L	h	
Milli meter	MIN	0.70	-	0.25	0.18	3.90	2.10	0.65 BSC	1.95 BSC	1.95 BSC	3.90	2.10	0.45	0.30
	NOM	0.75	0.02	0.30	0.20	4.00	2.20				4.00	2.20	0.55	0.35
	MAX	0.80	0.05	0.35	0.25	4.10	2.30				4.10	2.30	0.65	0.40