

### General Description

EC1745NN is a Synchronous Buck Circuit with two current sense pins suitable for many multi-output applications. It is designed to allow for operating a wide supply voltage range from 4.5V to 30V. This IC can operate in both Constant Current (CC) and Constant Voltage (CV) modes. EC1745NN operates as a Buck Circuit providing a wide range of outputs at Constant Voltage (CV) from 4.5V to 30V and the output current as high as 6A or above. It has a Constant Current (CC) mode so that output current can be set externally and at an accuracy of  $\pm 4\%$ . The current mode control and external compensation makes feedback control have good line and load regulation with flexible external design.

### Features

- ◆ Vin: 4.5V to 30V
- ◆ Vout: 3V to 28V; typical at 5V
- ◆ Low Dropout Operation: Maximum Duty Cycle at 99.5%
- ◆ Precision CC/CV Mode Control
- ◆ Burst/PFM Mode for Increased Light Load Efficiency
- ◆ 2 outputs independent Constant Current setting
- ◆ Hiccup mode when output voltage below 50% normal output voltage
- ◆ Protection:
- ◆ NMOS peak current limit: accuracy :  $\sim 20\%$  Output short protection: reduce input current to less than 20mA (RMS)
- ◆ Output FB OVP (125% VFB), only turn off High side MOS.
- ◆ Temperature shutdown (OTP)
- ◆ Adjustable Output Cable Resistance Compensation
- ◆ Switching Frequency: 375k+75k
- ◆ Integrated Power MOSFET
- ◆ QFN32L Package

### Applications

- ◆ USB Power Supplies with PD
- ◆ High-Brightness Lighting
- ◆ General-Purpose DC/DC Application

### Pin Configurations

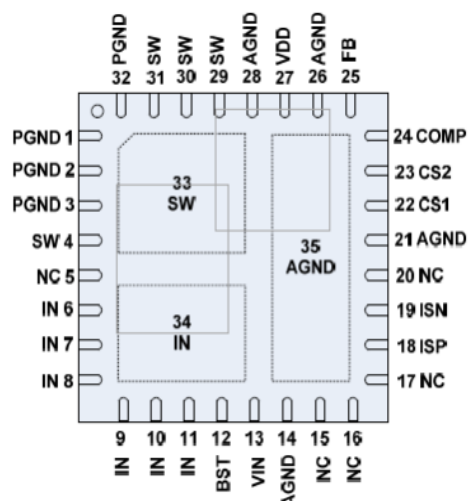

Figure1 Pin Configuration of EC1745NN (Top view)



## Pin Description

Pin Number	Pin Name	Description
1,2,3, 32	PGND	Power Ground pin.
4, 29,30,31,33	SW	Inductor terminal.
5,15,16,17,20	NC	Not connected
6,7,8,9,10,11,34	IN	Power input
12	BST	Internal High Side Driver Power Bias which is typically 5V above Vin. A typical 0.1uF capacitor is used connecting between BST and SW pins.
13	VIN	Supply input
14,21,26,28,35	AGND	Signal Ground for The IC.
18	ISP	Input Current Sense.
19	ISN	Input Current Sense.
22	CS1	Current sense of the 1st output.
23	CS2	Current sense of the 2nd output.
24	COMP	Error Amplifier Output. The Converter stability compensation network is placed.
25	FB	Feedback input with reference to 1.20V. It can set output voltage.
27	VDD	Internal 5v power supply, a 1uF (or more) capacitor is connected between this pin and GND.

## Ordering Information

# EC1745NN



Circuit Type

Q6: DFN

Packing:

Blank: Tube

R: Tape and Reel

Marking rule:

Part Number	Package	Marking	Marking Information
EC1745NNQ6R	QFN32L	EC1745N LLLLL YYWW	LLLLL is Lot Number YYWW is date code

### Function Block

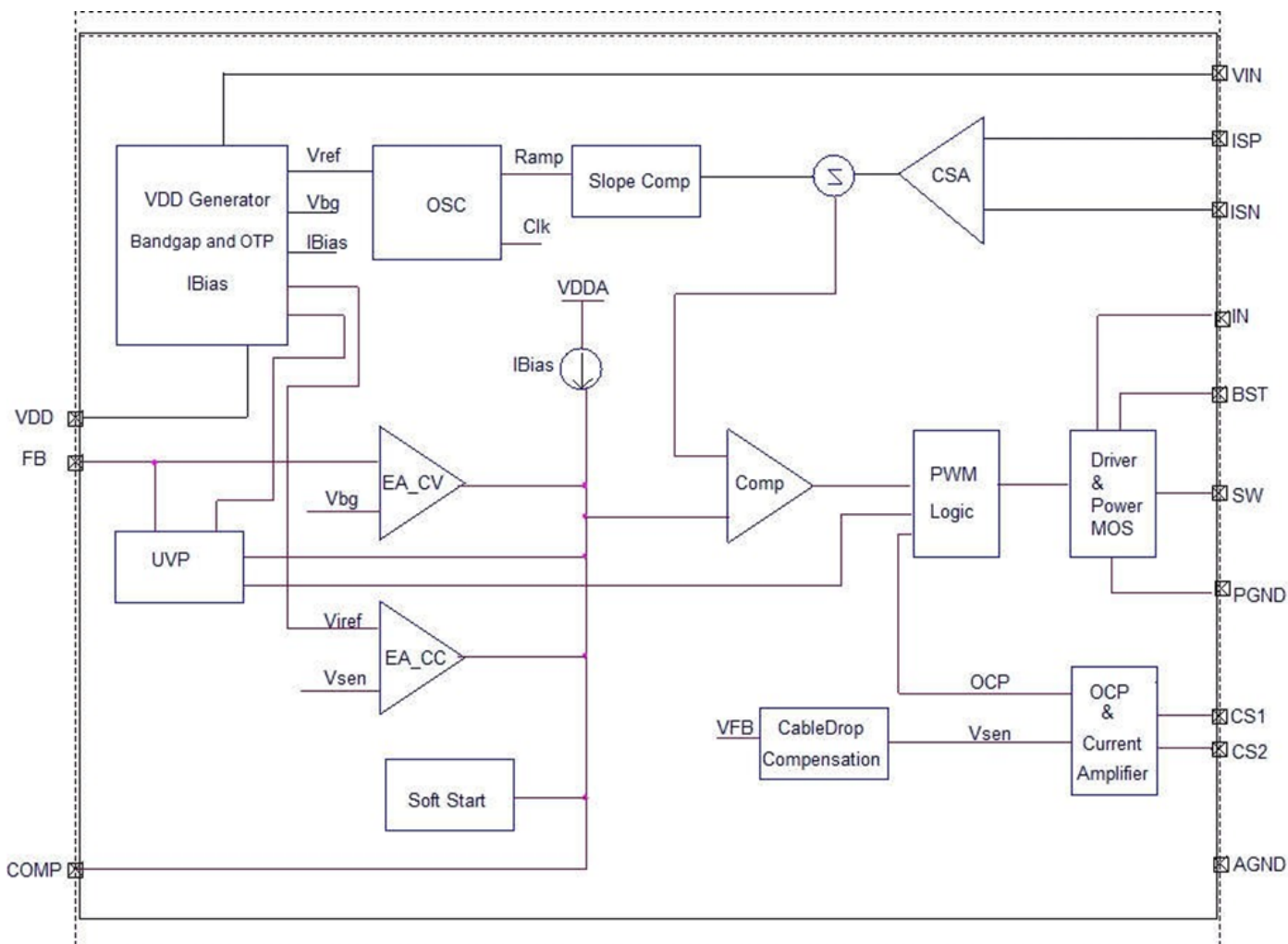

Figure 2 Function Block Diagram of EC1745NN

### Absolute Maximum Ratings (Note1)

Symbol	Parameter	Rating	Unit
VIN	Supply Input Voltage	-0.3 to +30	V
	ISP, ISN to VIN	-0.3 to +0.3	V
	BST to SW	-0.3 to +6	V
	SW to GND	-0.3 to VIN+0.6	V
	BST to GND	VSW-0.3 to VSW+6	V
	VDD, VFB, ISET, COMP, CS1-2 to GND	-0.3 to +6	V
ESD	HBM (Human Body Mode)	2K	V
$\theta_{JA}$	Thermal Resistance from Junction to ambient	40	°C/W



## Recommended Operation Conditions

Symbol	Parameter	Rating			Unit
		Min.	Typ.	Max.	
V <sub>IN</sub>	Supply Voltage	4.7*	-	30	V
V <sub>OUT</sub>	Output voltage range	3	-	28	V
I <sub>OUT</sub>	Output current range	-	-	10	A
T <sub>OP</sub>	Operating Temperature	-40	-	85	°C
T <sub>STG</sub>	Storage Temperature Range	-65	-	150	°C
T <sub>J</sub>	Junction Temperature	-40	-	150	°C
T <sub>SDR</sub>	Maximum Lead Soldering Temperature, 10 Seconds	260			°C

Note: \* when supply voltage is around 5V, output load current should be less than 5A.

## Electrical Characteristics

V<sub>IN</sub>=12V, T<sub>A</sub>=25°C (unless otherwise specified).

Symbol	Characteristic	Test conditions	Min	Typ	Max	Unit
V <sub>IN</sub>	Supply Voltage		4.5	-	30	V
I <sub>IN</sub>	Supply Input Current	V <sub>out</sub> =5V, No load	1	1.7	3.5	mA
<b>VIN UVLO</b>						
V <sub>UP</sub>	VIN UVLO Turn ON	VIN Rising	3.5	4	4.5	V
V <sub>HYS</sub>	VIN UVLO Hysteresis	VIN Falling	-	0.6	-	V
<b>Feedback voltage</b>						
V <sub>FB</sub>	Feedback voltage		1.176	1.2	1.224	V
	Tolerance		-2	-	2	%
<b>Soft Start</b>						
	Soft Start time		-	6	-	ms
<b>Oscillator</b>						
F <sub>SW</sub>	Switch frequency		300	375	450	KHz
TON	Minimum On-Time		-	100	-	ns
D	Duty cycle		-	-	99.5	%
<b>Current sense</b>						
V <sub>THCC</sub>	CC threshold		65	68	71	mV
I <sub>FB</sub>	Cable compensation Current	CS1-2=68mv	-	2	-	uA
<b>POWER MOSFET</b>						
	High Side MOSFET Resistance		-	6	-	mΩ
	Low Side MOSFET Resistance		-	14	-	mΩ
<b>Thermal Shutdown(OTP)</b>						
T <sub>SD</sub>	Temperature Rising		-	150	-	°C
T <sub>HYS</sub>	OTP Hysteresis		-	20	-	°C

### Typical Operating Characteristics

Figure 3 2-outputs with 2.4A+2.4A(CS1 and CS2)

Figure 4 1-outputs with 5V/5A

### Function Description

EC1745NN operates in a peak-current-mode control to regulate the output voltage. It integrates a monolithic synchronous, rectified, step-down, switch-mode converter with internal power MOSFETs. It offers a compact solution to achieve 6A of continuous output current over a wide input-supply range with excellent load and line regulation. The internal clock initiates the PWM cycle, which turns on the integrated high side power MOSFET. The high-side MOSFET remains on until its current reaches the value set by the COMP voltage. When the power switch is off, it remains off until the next clock cycle begins.

#### CC/CV Mode Control

EC1745NN provides CC/CV function. The Constant output Current control Mode and Constant output Voltage control Mode.

#### Output Voltage Setting

VFB is the feedback pin and connected to the non-inverting of error amplifier input. The output voltage is adjustable from 1.2V to 28V with a resistor-divider connected with VFB GND and converter's output. Using 1% or better resistors for the resistor-divider is recommended.

The output voltage is determined by the equation:  $V_{OUT} = V_{FB} * (1 + R1/R2) = 1.2V * (1 + R1/R2)$

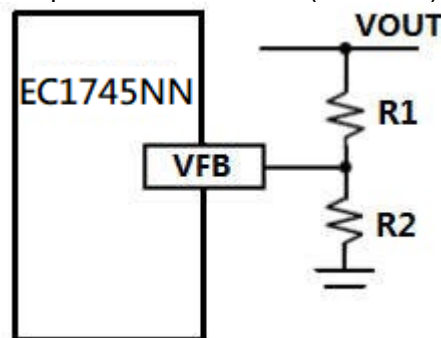

R1 can program the cable compensation.

#### FB OVP

If  $FB > 125% * 1.2V$ , the controller turn off the high side PWR MOS immediately.

#### FB UVP

For EC1745NN, Hiccup Mode of Under Voltage Protection (UVP) is provided. If cc mode is triggered or over current protection(OCP)/short current protection(SCP) occur, the output voltage will be pulled down quickly. When  $FB < 50% * V_{FB}$ , the controller will enter hiccup mode by disabling the converter and restarts soft-start after a predefined interval about 4s until the under voltage condition is removed.

#### FB Fast response

If  $FB > 105% * 1.2V$  or  $FB < 95%$ , the controller turn off or turn on the high side PWR MOS immediately. This design reduce the overshoot and undershoot when load change suddenly

#### Soft start

The controller integrates a soft start circuit. The soft time is 6ms roughly.

#### Constant Current setting

The voltage of CS1 or CS2 pins reaches the voltage on VTHCC(68mV), the system will enter CC mode, the CC current can be calculated by followings:

$$I_{CC} = V_{THCC} / (R_{CS1} \text{ or } R_{CS2})$$

Here  $R_{CS1}$ ,  $R_{CS2}$  are the sense resistors between CS1, CS2 and GND.

### Output Cable Resistance Compensation

To compensate for resistive voltage drop across the charger's output cable, the controller integrates a simple, user-programmable cable voltage drop compensation using the impedance at the FB pin. By choosing different  $R1$ , we can get different cable voltage drop compensation values.

$$V_{cdc} = (V_{cs1} \text{ or } V_{cs2}) * R1 / 34000 \quad (V_{cs1} \text{ or } V_{cs2} > 8\text{mv})$$

### Over Temperature Protection (OTP)

EC1745NN provides over temperature protection (OTP). The OTP will shut down the converter when junction temperature exceeds 150°C. Once the junction temperature cools down by approximately 30°C, the controller will resum

### Output Inductor Selection

The inductor value (L) determines the inductor ripple current,  $I_{RIPPLE}$  and affects the load transient response. Higher inductor value reduces the inductor's ripple current and induces lower output ripple voltage. The ripple current and ripple voltage can be approximated by:

$$L = V_{OUT} * (V_{IN} - V_{OUT}) / F_{SW} * I_{RIPPLE} * V_{IN}$$

Where

$F_{SW}$  : the switching frequency of the regulator;  $V_{IN}/V_{OUT}$  : input voltage/output voltage;

$I_{RIPPLE}$  is the inductor ripple current and  $I_{RIPPLE} = (0.3-0.5)I_{OUT}$

### Input Capacitor

A low ESR capacitor is highly recommended. Since large current flows in and out of this capacitor during switching, its ESR also affects efficiency.

The input capacitance should be higher than 100µF. The best choice is the ceramic type, however, low ESR tantalum or electrolytic types may also be used. The input capacitor should be placed close to the VIN and GND pins of the IC, with the shortest traces possible. In the case of tantalum or electrolytic types, they can be further away if a small parallel 1µF ceramic capacitor is placed right next to the IC.

### Output Capacitor

The system requires the output capacitor to maintain the dc output voltage. The characteristics of the output capacitor affect the stability of the regulatory system. A low ESR electrolytic capacitor is recommended for a low output ripple and good control loop stability. For general applications, a 1µF ceramic capacitor and a 330µF (or more) polymer/electrolytic capacitor are recommended.



## Package Information

### QFN5x5-32L Package Outline Dimensions

SYMBOL	A	A1	A2	b	D	D1	D2	D3	E	E1	E2	E3	e	L	K	K1	
Milli	MIN	0.7	0.05	0.203	0.2	4.95	1.4	1.75	3.6	4.95	1.95	1.95	1.2	0.5	0.3	0.25	0.35
meter	MAX	0.8	MAX	REF	0.3	5.05	1.6	1.95	3.8	5.05	2.15	2.15	1.4	BSC	0.5	BSC	BSC
Inch	MIN	0.0276	0.002	0.008	0.0079	0.1949	0.0551	0.0689	0.1417	0.1949	0.0768	0.0768	0.0472	0.0197	0.0118	0.0098	0.0138
	MAX	0.0315	MAX	REF	0.0118	0.1988	0.063	0.0768	0.1496	0.1988	0.0846	0.0846	0.0551	BSC	0.0197	BSC	BSC