

64K bits Two-wire Serial EEPROM

General Description

The EC24C64C is an industrial standard electrically erasable programmable read only memory (EEPROM) device that utilizes the industrial standard 2-wire interface for communications. The EC24C64C contains a memory array of 64K bits (8,192x8), which is organized in 32-byte per page.

The EEPROM operates in a wide voltage range from 1.7V to 5.5V, which fits most application. The product provides low-power operations and low standby current. The device is offered in Lead-free, RoHS, halogen free or Green package. The available package types are 8-pin SOP, TSSOP, DFN, MSOP.

The EC24C64C is compatible to the standard 2-wire bus protocol. The simple bus consists of Serial Clock (SCL) and Serial Data (SDA) signals. Utilizing such bus protocol, a Master device, such as a microcontroller, can usually control one or more Slave devices, alike this EC24C64C.

The bit stream over the SDA line includes a series of bytes, which identifies a particular Slave device, an instruction, an address within that Slave device, and a series of data, if appropriate. The EC24C64C also has a Write Protect

Function via WP pin to cease from overwriting the data stored inside the memory array.

In order to refrain the state machine from entering into a wrong state during power-up sequence or a power toggle off-on condition, a power on reset circuit is embedded. During power-up, the device does not respond to any instructions until the supply voltage (VCC) has reached an acceptable stable level above the reset threshold voltage.

Once VCC passes the power on reset threshold, the device is reset and enters into the Standby mode. This would also avoid any inadvertent Write operations during power-up stage. During power-down process, the device will enter into standby mode, once VCC drops below the power on reset threshold voltage. In addition, the device will be in standby mode after receiving the Stop command, provided that no internal write operation is in progress. Nevertheless, it is illegal to send a command unless the VCC is within its operating level.

This product offers an additional page (Identification Page) of 32 bytes. The Identification Page can be used to store sensitive application parameters which can be (later) permanently locked in Read-only mode.

Features

- Two-Wire Serial Interface, I²C™ Compatible
 - Bi-directional data transfer protocol
- Wide-voltage Operation
 - VCC = 1.7V to 5.5V
- Speed: 400 KHz (1.7V) and 1 MHz (2.5V~5.5V)
- Standby current (max.): 1µA, 1.7V
- Operating current (max.): 0.8mA, 5.5V
- Hardware Data Protection
 - Write Protect Pin
- Sequential & Random Read Features
- Memory organization: 8,192 x 8 bits
- Page Size: 32 bytes
- Page write mode
 - partial page writes allowed
- Addition write lockable page(identification page)
- Self timed write cycle: 5ms (max.)
- Noise immunity on inputs, besides Schmitt trigger
- High-reliability
 - Endurance: 1 million cycles
 - Data retention: 100 years
- Industrial temperature grades
- Packages: SOP, TSSOP, MSOP, DFN
- Lead-free, RoHS, Halogen free, Green

64K bits Two-wire Serial EEPROM

Ordering Information & Marking Information

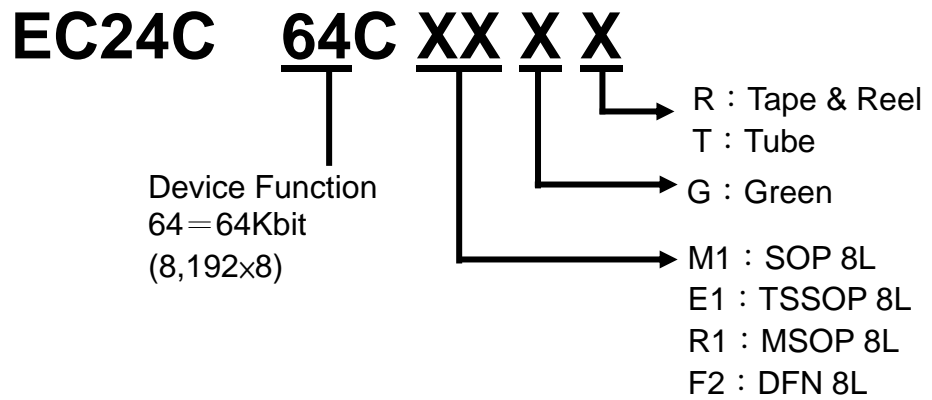

Functional Block Diagram

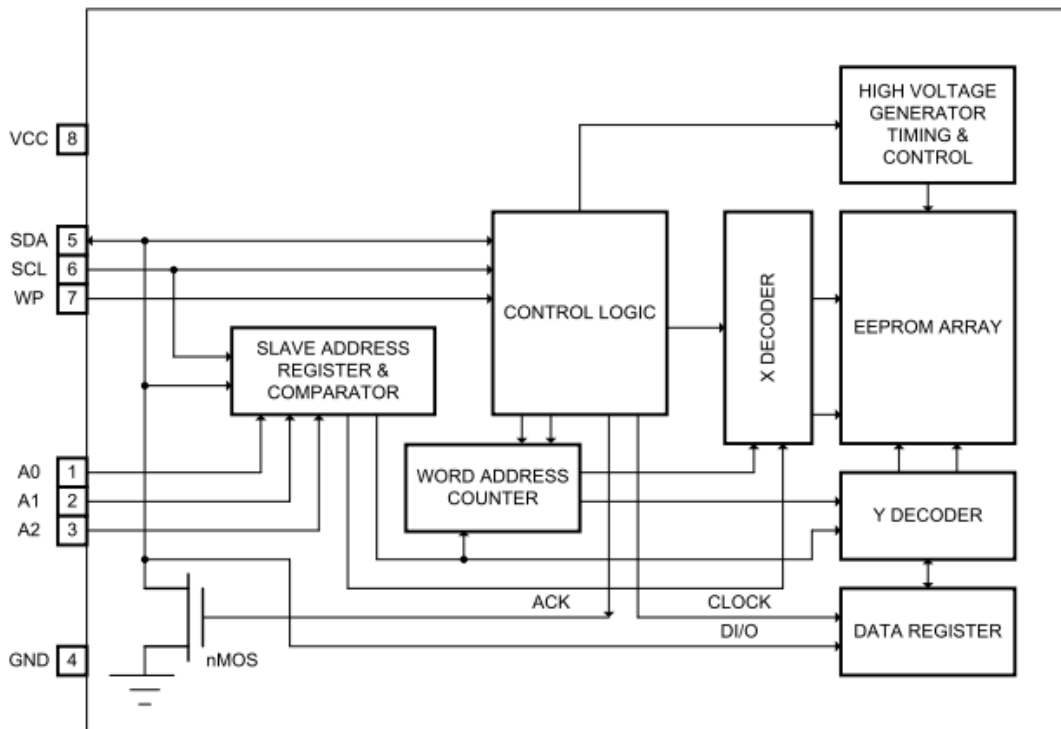

64K bits Two-wire Serial EEPROM

Pin Configuration

(SOP 8L / TSSOP 8L / MSOP 8L)

(DFN 8L)

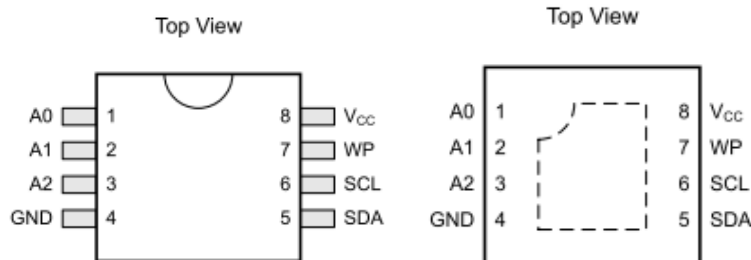

Pin Definition

Pin No.	Pin Name	I/O	Definition
1	A0	I	Device Address Input
2	A1	I	Device Address Input
3	A2	I	Device Address Input
4	GND	-	Ground
5	SDA	I/O	Serial Address and Data input and Data out put
6	SCL	I	Serial Clock Input
7	WP	I	Write Protect Input
8	VCC	-	Power Supply

Pin Descriptions

SCL

This input clock pin is used to synchronize the data transfer to and from the device.

SDA

The SDA is a bi-directional pin used to transfer addresses and data into and out of the device. The SDA pin is an open drain output and can be wired with other open drain or open collector outputs. However, the SDA pin requires a pull-up resistor connected to the power supply.

A0, A1, A2

The A0, A1 and A2 are the device address inputs. Typically, the A0, A1, and A2 pins are for hardware addressing and a total of 8 devices can be connected on a single bus system. When A0, A1, and A2 are left floating, the inputs are defaulted to zero.

WP

WP is the Write Protect pin. While the WP pin is connected to the power supply of EC24C64C, the entire array becomes Write Protected (i.e. the device becomes Read only). When WP is tied to Ground or left floating, the normal write operations are allowed.

VCC

Supply voltage

GND

Ground of supply voltage

64K bits Two-wire Serial EEPROM

Device Operation

The EC24C64C serial interface supports communications using industrial standard 2-wire bus protocol, such as I²C.

2-WIRE Bus

The two-wire bus is defined as Serial Data (SDA), and Serial Clock (SCL). The protocol defines any device that sends data onto the SDA bus as a transmitter, and the receiving devices as receivers. The bus is controlled by Master device that generates the SCL, controls the bus access, and generates the Start and Stop conditions. The EC24C64C is the Slave device.

The Bus Protocol

Data transfer may be initiated only when the bus is not busy. During a data transfer, the SDA line must remain stable whenever the SCL line is high. Any changes in the SDA line while the SCL line is high will be interpreted as a Start or Stop condition.

The state of the SDA line represents valid data after a Start condition. The SDA line must be stable for the duration of the High period of the clock signal. The data on the SDA line may be changed during the Low period of the clock signal. There is one clock pulse per bit of data. Each data transfer is initiated with a Start condition and terminated by a Stop condition.

Start Condition

The Start condition precedes all commands to the device and is defined as a High to Low transition of SDA when SCL is High. The EEPROM monitors the SDA and SCL lines and will not respond until the Start condition is met.

Stop Condition

The Stop condition is defined as a Low to High transition of SDA when SCL is High. All operations must end with a Stop condition.

Acknowledge

After a successful data transfer, each receiving device is required to generate an ACK. The Acknowledging device pulls down the SDA line.

Reset

The EC24C64C contains a reset function in case the 2-wire bus transmission on is accidentally interrupted (e.g. a power loss), or needs to be terminated mid-stream.

The reset is initiated when the Master device creates a Start condition. To do this, it may be necessary for the Master device to monitor the SDA line while cycling the SCL up to nine times. (For each clock signal transition to High, the Master checks for a High level on SDA.)

Standby Mode

While in standby mode, the power consumption is minimal. The EC24C64C enters into standby mode during one of the following conditions: a) After Power-up, while no Op-code is sent; b) After the completion of an operation and followed by the Stop signal, provided that the previous operation is not Write related; or c) After the completion of any internal write operations.

Device Addressing

The Master begins a transmission on by sending a Start condition, then sends the address of the particular Slave devices to be communicated. The Slave device address is 8 bits format as shown in Figure. 5.

The four most significant bits of the Slave address are fixed (1010) for EC24C64C. The next three bits, A0, A1 and A2, of the Slave address are specifically related to EEPROM. Up to eight EC24C64C units can be connected to the 2-wire bus. The last bit of the Slave address specifies whether a Read or Write operation is to be performed. When this bit is set to 1, Read operation is selected. While it is set to 0, Write operation is selected. After the Master transmits the Start condition and Slave address byte appropriately, the associated 2-wire Slave device, EC24C64C, will respond with ACK on the SDA line. Then EC24C64C will pull down the SDA on the ninth clock cycle, signaling that it received the eight bits of data. The EC24C64C then prepares for a Read or Write operation by monitoring the bus.

64K bits Two-wire Serial EEPROM

Write Operation

Byte Write

In the Byte Write mode, the Master device sends the Start condition and the Slave address information (with the R/W set to Zero) to the Slave device. After the Slave generates an ACK, the Master sends the byte address that is to be written into the address pointer of the EC24C64C. After receiving another ACK from the Slave, the Master device transmits the data byte to be written into the address memory location. The EC24C64C acknowledges once more and the Master generates the Stop condition, at which time the device begins its internal programming cycle. While this internal cycle is in progress, the device will not respond to any request from the Master device.

Page Write

The EC24C64C is capable of 32-byte Page-Write operation. A Page-Write is initiated in the same manner as a Byte Write, but instead of terminating the internal Write cycle after the first data word is transferred, the Master device can transmit up to 31 more bytes. After the receipt of each data word, the EEPROM responds immediately with an ACK on SDA line, and the seven lower order data word address bits are internally incremented by one, while the higher order bits of the data word address remain constant. If a byte address is incremented from the last byte of a page, it returns to the first byte of that page. If the Master device should transmit more than 32bytes prior to issuing the Stop condition, the address counter will “roll over,” and the previously written data will be overwritten. Once all 32 bytes are received and the Stop condition has been sent by the Master, the internal programming cycle begins. At this point, all received data is written to the EC24C64C in a single Write cycle. All inputs are disabled until completion of the internal Write cycle.

Acknowledge (ACK) Polling

The disabling of the inputs can be used to take advantage of the typical Write cycle time. Once the Stop condition is issued to indicate the end of the host's Write operation, the EC24C64C initiates the internal Write cycle. ACK polling can be initiated immediately.

This involves issuing the Start condition followed by the Slave address for a Write operation. If the EEPROM is still busy with the Write operation, no ACK will be returned. If the EC24C64C has completed the Write operation, an ACK will be returned and the host can then proceed with the next Read or Write operation.

Write Identification Page

The Identification Page(32 bytes) is an additional page which can be written and (later) permanently locked in Read-only mode. It is written by issuing the Write Identification Page instruction. This instruction uses the same protocol and format as Page Write (into memory array), except for the following differences:

- Device type identifier=1011b
- MSB address bits A15/A5 are don't care except for address bit A10 which must be '0'. LSB address bits A4/A0 define the byte address inside the Identification page.

If the Identification page is locked, the data bytes transferred during the Write Identification Page instruction are not acknowledged (NoACK).

Lock Identification Page

The Lock Identification Page instruction (Lock ID) permanently locks the Identification page In Read-only mode. The lock ID instruction is similar to Byte Write (into memory array) with the following specific condition:

- Device type identifier=1011b
- Address bit A10 must be '1'; all other address bits are don't care
- The data byte must be equal to the binary value xxxx xx1x, where x is don't care

64K bits Two-wire Serial EEPROM

Read Operation

Read Operation

Read operations are initiated in the same manner as Write operations, except that the (R/W) bit of the Slave address is set to “1”. There are three Read operation options: current address read, random address read and sequential read.

Current Address Read

The EC24C64C contains an internal address counter which maintains the address of the last byte accessed, incremented by one. For example, if the previous operation is either a Read or Write operation addressed to the address location n , the internal address counter would increment to address location $n+1$. When the EEPROM receives the Slave Addressing Byte with a Read operation (R/W bit set to “1”), it will respond an ACK and transmit the 8-bit data byte stored at address location $n+1$. The Master should not acknowledge the transfer but should generate a Stop condition so the EC24C64C discontinues transmission. If 'n' is the last byte of the memory, the data from location '0' will be transmitted. (Refer to Figure 8. Current Address Read Diagram.)

Random Address Read

Selective Read operations allow the Master device to select at random any memory location for a Read operation. The Master device first performs a 'dummy' Write operation by sending the Start condition, Slave address and byte address of the location it wishes to read. After the EC24C64C acknowledges the byte address, the Master device resends the Start condition and the Slave address, this time with the R/W bit set to one. The EEPROM then responds with its ACK and sends the data requested. The Master device does not send an ACK but will generate a Stop condition. (Refer to Figure 9. Random Address Read Diagram.)

Sequential Read

Sequential Reads can be initiated as either a Current Address Read or Random Address Read. After the EC24C64C sends the initial byte sequence, the Master device now responds with an ACK indicating it requires additional data from the EC24C64C. The EEPROM continues to output data for each ACK received. The Master device terminates the sequential Read operation by pulling SDA High (no ACK) indicating the last data word to be read,

followed by a Stop condition. The data output is sequential, with the data from address n followed by the data from address $n+1, n+2 \dots$ etc. The address counter increments by one automatically, allowing the entire memory contents to be serially read during sequential Read operation. When the memory address boundary of the array is reached, the address counter “rolls over” to address 0, and the device continues to output data. (Refer to Figure 10. Sequential Read Diagram).

Read Identification Page

The Identification Page (32 bytes) is an additional page which can be written and (later) permanently locked in Read-only mode.

The Identification Page can be read by issuing an Read Identification Page instruction. This instruction uses the same protocol and format as the Random Address Read (from memory array) with device type identifier defined as 1011b. The MSB address bits A15/A6 are don't care, the LSB address bits A5/A0 define the byte address inside the Identification Page. The number of bytes to read in the ID page must not exceed the page boundary (e.g.: when reading the Identification Page from location 10d, the number of bytes should be less than or equal to 22, as the ID page boundary is 32 bytes).

Read the lock status

The locked/unlocked status of the Identification page can be checked by transmitting a specific truncated command [Identification Page Write instruction + one data byte] to the device. The device returns an acknowledge bit if the Identification page is unlocked, otherwise a NoAck bit if the Identification page is locked. Right after this, it is recommended to transmit to the device a Start condition followed by a Stop condition, so that:

- Start: the truncated command is not executed because the Start condition resets the device internal logic,
- Stop: the device is then set back into Standby mode by the Stop condition.

64K bits Two-wire Serial EEPROM

Diagrams

Figure 1. Typical System Bus Configuration

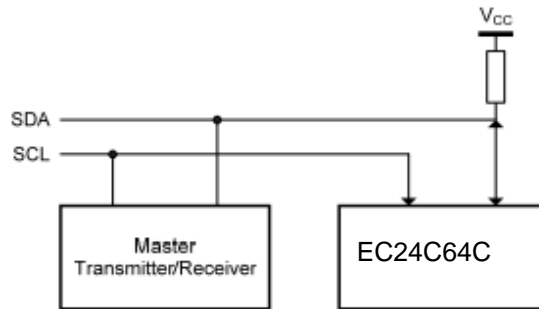

Figure 2. output Acknowledge



Figure 3. Start and Stop Conditions

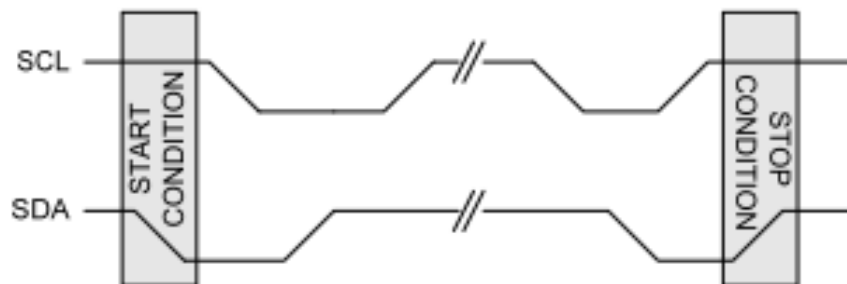
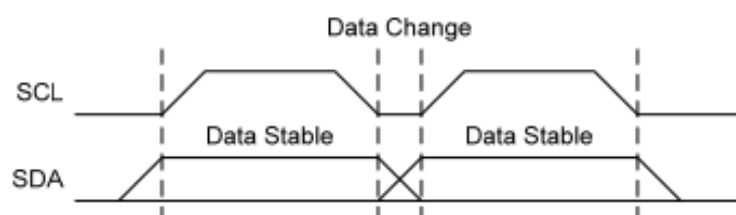

Figure 4. Data Validity Protocol



64K bits Two-wire Serial EEPROM

Figure 5. Slave Address



Figure 6. Byte Write

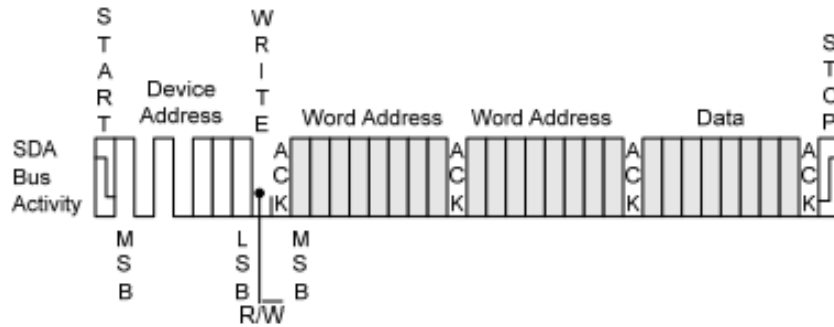

Figure 7. Page Write

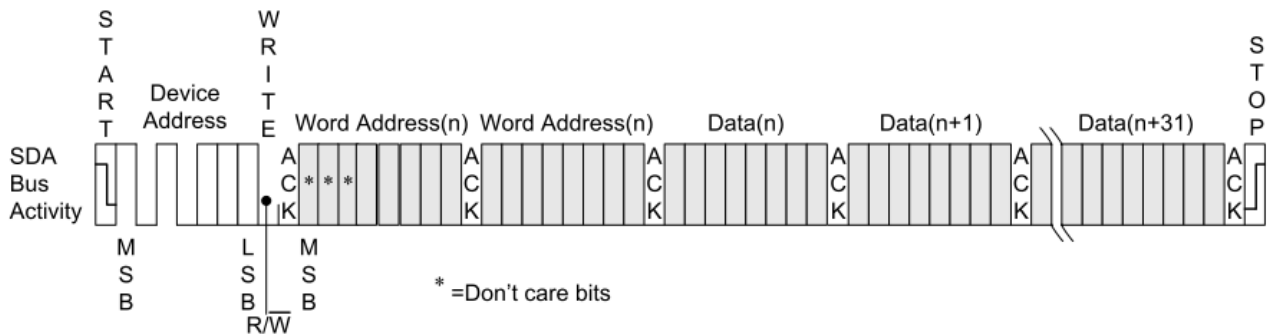
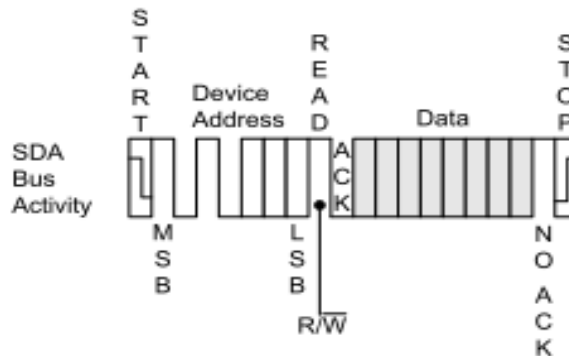

Figure 8. Current Address Read



64K bits Two-wire Serial EEPROM

Figure 9. Random Address Read

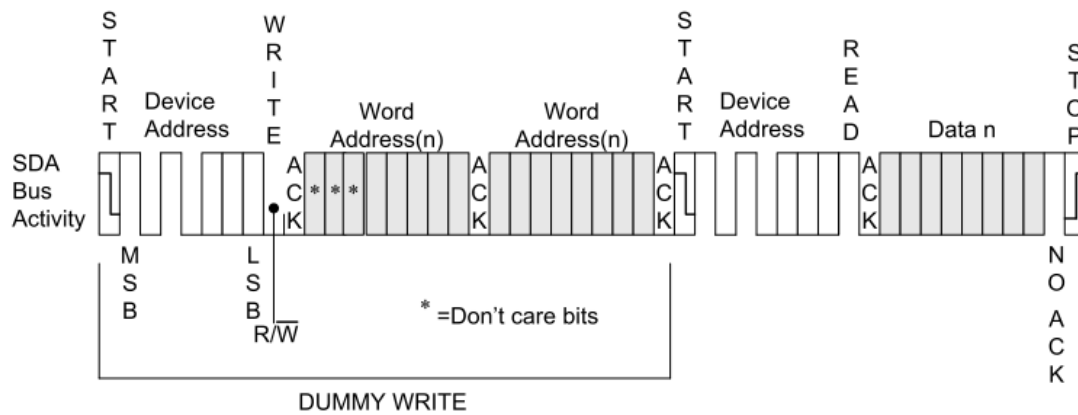
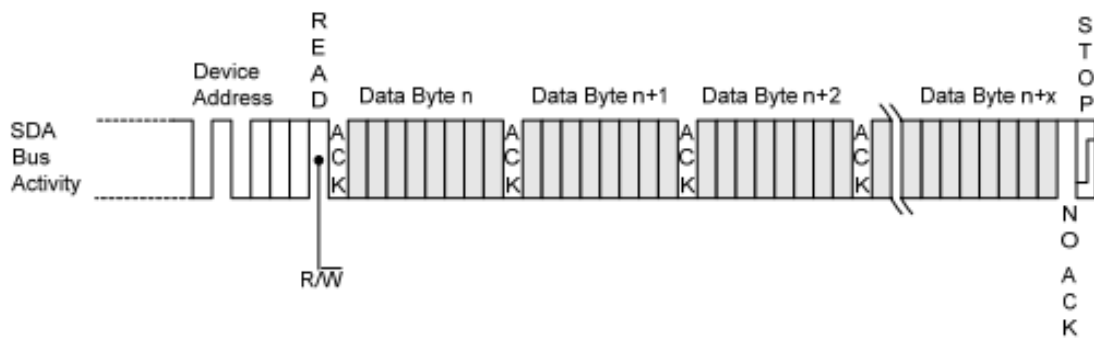

Figure 10. Sequential Read



64K bits Two-wire Serial EEPROM

Timing Diagrams

Figure 11 .Bus Timing

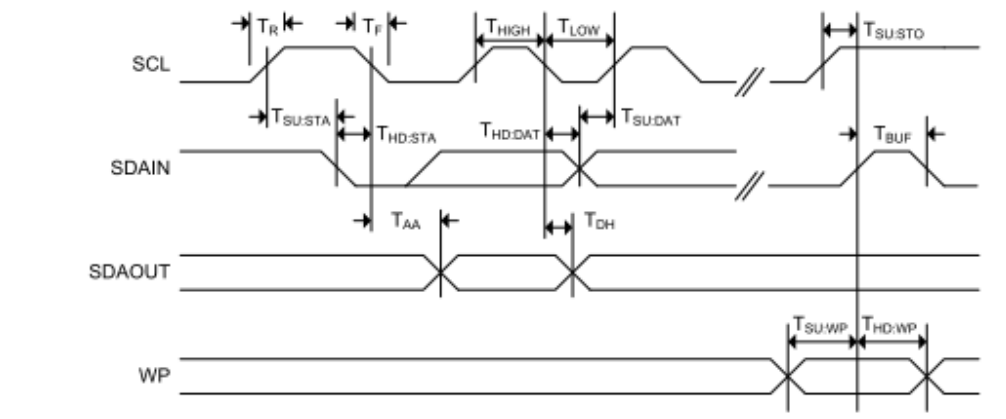
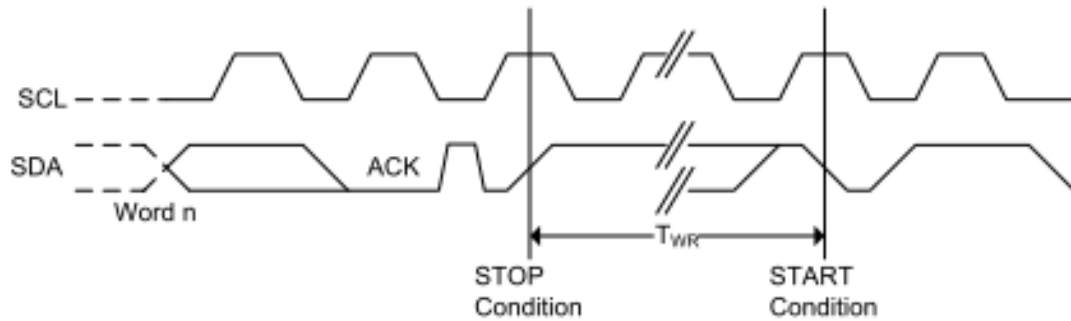

Figure 12. Write Cycle Timing



64K bits Two-wire Serial EEPROM

Electrical Characteristics

Absolute Maximum Ratings

Symbol	Parameter	Value	Unit
V _S	Supply Voltage	-0.5 to + 6.5	V
V _P	Voltage on Any Pin	-0.5 to V _{CC} + 0.5	V
T _{BIAS}	Temperature Under Bias	-55 to +125	°C
T _{STG}	Storage Temperature	-65 to +150	°C
I _{OUT}	Output Current	5	mA

Note: Stress greater than those listed under Absolute Maximum Ratings may cause permanent damage to the device. This is a stress rating only and functional operation of the device at these or any other condition outside those indicated in the operational sections of this specification is not implied. Exposure to absolute maximum rating conditions for extended periods may affect reliability.

Operating Range

Range	Ambient Temperature (T _A)	V _{CC}
Industrial	-40°C to +85°C	1.7V to 5.5V

Capacitance

Symbol	Parameter ^[1,2]	Conditions	Max.	Unit
C _{IN}	Input Capacitance	V _{IN} = 0V	6	pF
C _{I/O}	Input / Output Capacitance	V _{I/O} = 0V	8	pF

Note: (1) Tested initially and after any design or process changes that may affect these parameters and not 100% tested.
 (2) Test conditions: T_A = 25°C, f = 1 MHz, V_{CC} = 5.0V.

64K bits Two-wire Serial EEPROM

DC Electrical Characteristic

Industrial: TA = -40°C to +85°C, VCC = 1.7V ~ 5.5V

Symbol	Parameter ^[1]	VCC	Test Conditions	Min.	Typ.	Max.	Unit
VCC	Supply Voltage			1.7	--	5.5	V
VIH	Input High Voltage			0.7*VCC	--	VCC+1	V
VIL	Input Low Voltage			-1	--	0.3* VCC	V
ILI	Input Leakage Current	5V	VIN = VCC max	--	--	2	μA
ILO	Output Leakage Current	5V		--	--	2	μA
VOL1	Output Low Voltage	1.7V	IOL = 0.15 mA	—	--	0.2	V
VOL2	Output Low Voltage	2.5V	IOL = 2.1 mA	—	--	0.4	V
ISB1	Standby Current	1.7V	VIN = VCC or GND	—	0.2	1	μA
ISB2	Standby Current	2.5V	VIN = VCC or GND	—	0.3	1	μA
ISB3	Standby Current	5V	VIN = VCC or GND	—	0.5	1	μA
ICC1	Read Current	1.7V	Read at 400 KHz	—	—	0.15	mA
ICC1	Read Current	2.5V	Read at 1 MHz	—	—	0.2	mA
ICC1	Read Current	5.5V	Read at 1 MHz	—	—	0.5	mA
ICC2	Write Current	1.7V	Write at 400 KHz	—	—	0.5	mA
ICC2	Write Current	2.5V	Write at 1 MHz	—	—	0.6	mA
ICC2	Write Current	5.5V	Write at 1 MHz	—	—	0.8	mA

Note: The parameters are characterized but not 100% tested.



64K bits Two-wire Serial EEPROM

AC Electrical Characteristic

Industrial: TA = -40°C to +85°C, Supply voltage = 1.7V to 5.5V

Symbol	Parameter ^{[1][2]}	1.7V ≤ VCC < 2.5V		2.5V ≤ VCC < 4.5V		4.5V ≤ VCC ≤ 5.5V		Unit
		Min.	Max.	Min.	Max.	Min.	Max.	Unit
F _{SCL}	SCK Clock Frequency		400		1000		1000	KHz
T _{LOW}	Clock Low Period	1200	—	400	—	400	—	ns
T _{HIGH}	Clock High Period	600	—	400	—	400	—	ns
T _R	Rise Time (SCL and SDA)	—	300	—	300	—	300	ns
T _F	Fall Time (SCL and SDA)	—	300	—	100	—	100	ns
T _{SU:STA}	Start Condition Setup Time	500	—	200	—	200	—	ns
T _{SU:STO}	Stop Condition Setup Time	500	—	200	—	200	—	ns
T _{HD:STA}	Start Condition Hold Time	500	—	200	—	200	—	ns
T _{SU:DAT}	Data In Setup Time	100	—	40	—	40	—	ns
T _{HD:DAT}	Data In Hold Time	0	—	0	—	0	—	ns
T _{AA}	Clock to Output Access time (SCL Low to SDA Data Out Valid)	100	900	50	400	50	400	ns
T _{DH}	Data Out Hold Time (SCL Low to SDA Data Out Change)	100	—	50	—	50	—	ns
T _{WR}	Write Cycle Time	—	5	—	5	—	5	ms
T _{BUF}	Bus Free Time Before New Transmission	1000	—	400	—	400	—	ns
T _{SU:WP}	WP pin Setup Time	1000	—	400	—	400	—	ns
T _{HD:WP}	WP pin Hold Time	1000	—	400	—	400	—	ns
T	Noise Suppression Time	—	100	—	50	—	50	ns

Note: (1)The parameters are characterized but not 100% tested.

(2)AC measurement conditions:

RL (connects to VCC): 1.3 kΩ (2.5V, 5.0V), 10 kΩ (1.7V)

CL = 100 pF

Input pulse voltages: 0.3*VCC to 0.7*VCC

Input rise and fall times: ≤ 50 ns

Timing reference voltages: half VCC level

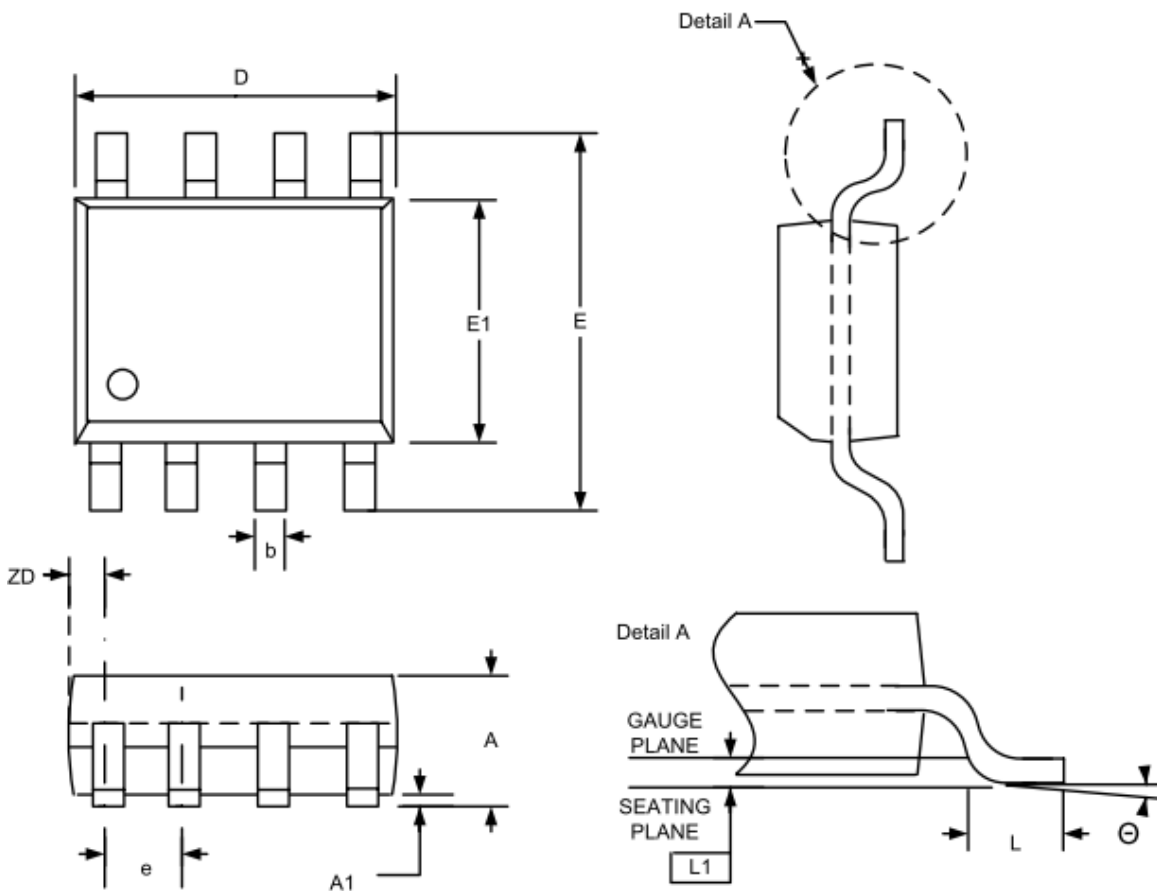
64K bits Two-wire Serial EEPROM
Package Information
SOP 8L

SYMBOLS	DIMENSIONS IN MILLIMETERS			DIMENSIONS IN INCHES		
	MIN	NOM	MAX	MIN	NOM	MAX
A	1.35	--	1.75	0.053	--	0.069
A1	0.10	--	0.25	0.004	--	0.010
b	0.33	--	0.51	0.013	--	0.020
D	4.80	--	5.00	0.189	--	0.197
E	5.80	--	6.20	0.228	--	0.244
E1	3.80	--	4.00	0.150	--	0.157
e	1.27 BSC.			0.050 BSC.		
L	0.38	--	1.27	0.015		0.050
L1	0.25 BSC.			0.010 BSC.		
ZD	0.545 REF.			0.021 REF.		
Θ	0	--	8°	0	--	8°

Note:

1. Controlling Dimension: MM
2. Dimension D and E1 do not include Mold protrusion
3. Dimension b does not include dambar protrusion/intrusion.
4. Refer to Jedec standard MS-012
5. Drawing is not to scale

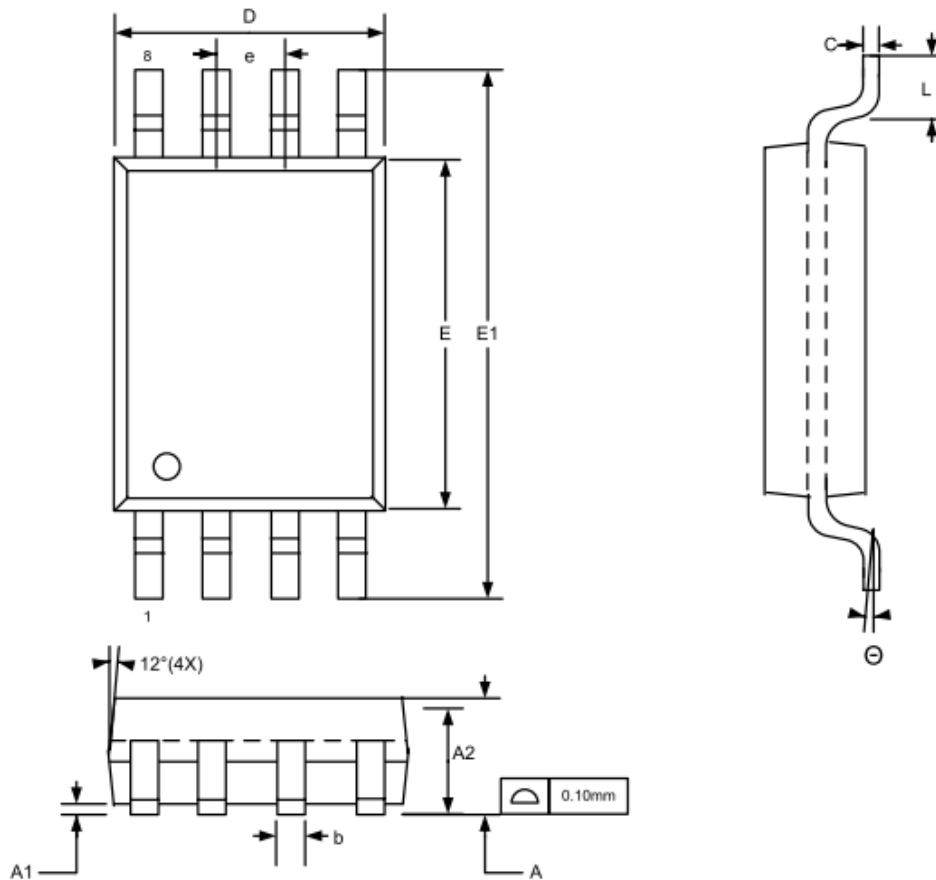
64K bits Two-wire Serial EEPROM
TSSOP 8L

SYMBOLS	DIMENSIONS IN MILLIMETERS			DIMENSIONS IN INCHES		
	MIN	NOM	MAX	MIN	NOM	MAX
A	--	--	1.20	--	--	0.047
A1	0.05	--	0.15	0.002	--	0.006
A2	0.80	1.00	1.05	0.031	0.039	0.041
b	0.19	--	0.30	0.007	--	0.012
c	0.09	--	0.20	0.004	--	0.008
D	2.90	3.00	3.10	0.114	0.118	0.122
E	4.30	4.40	4.50	0.169	0.173	0.177
E1	6.4 BSC			0.252 BSC		
e	0.65 BSC			0.026 BSC		
L	0.45	0.60	0.75	0.018	0.024	0.030
Θ	0	--	8°	0	--	8°

Note:

1. Controlling Dimension: MM
2. Dimension D and E do not include Mold protrusion
3. Dimension b does not include dambar protrusion/intrusion.
4. Refer to Jedec standard MO-153 AA
5. Drawing is not to scale
6. Package may have exposed tie bar.

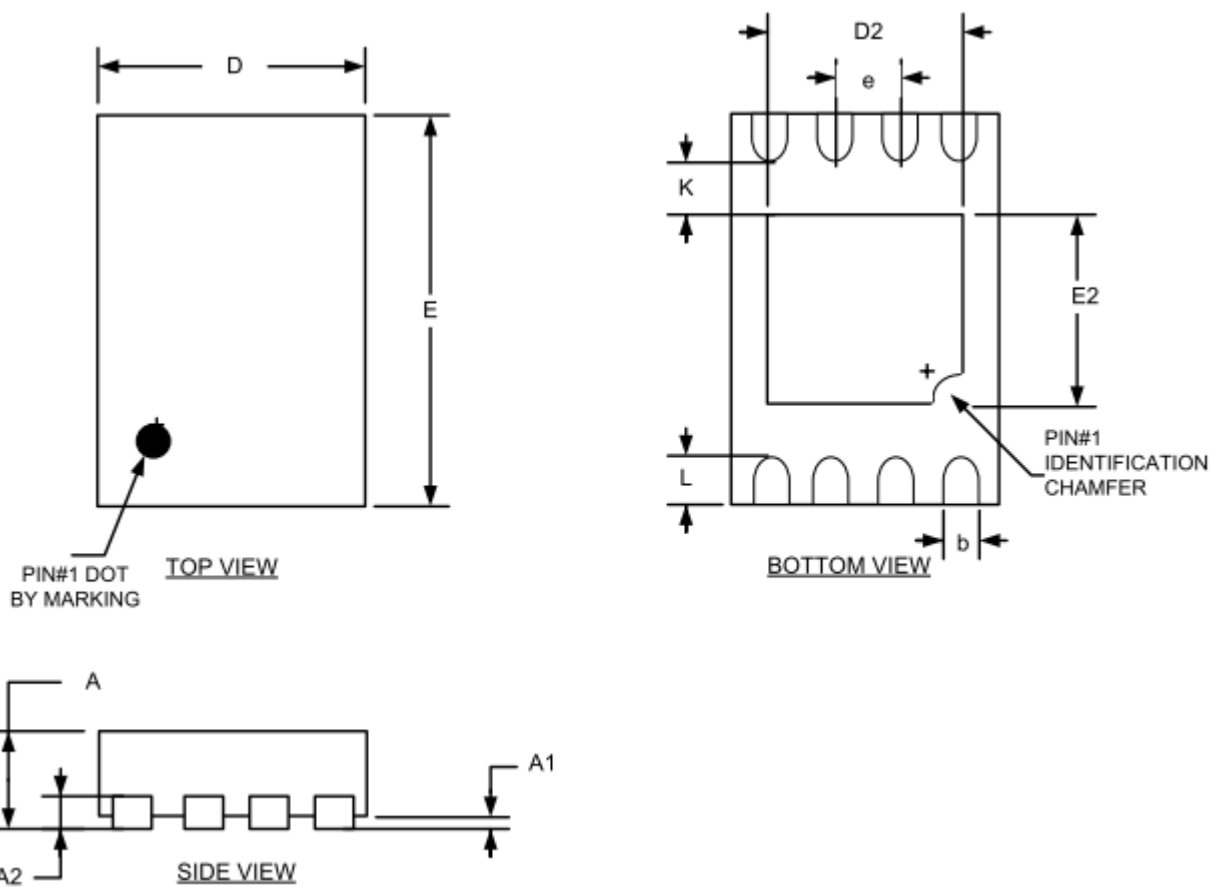
64K bits Two-wire Serial EEPROM
DFN 8L

SYMBOLS	DIMENSIONS IN MILLIMETERS			DIMENSIONS IN INCHES		
	MIN	NOM	MAX	MIN	NOM	MAX
A	0.50	0.55	0.60	0.020	0.022	0.024
A1	0.00	--	0.05	0.000	--	0.002
b	0.18	0.25	0.30	0.007	0.010	0.012
A2	0.152 REF			0.006 REF		
D	2.00 BSC			0.079 BSC		
D2	1.25	1.40	1.50	0.049	0.055	0.059
E	3.00 BSC			0.118 BSC		
E2	1.15	1.30	1.40	0.045	0.051	0.055
e	0.50 BSC.			0.020 BSC.		
K	0.40	--	--	0.016	--	--
L	0.20	0.30	0.40	0.008	0.012	0.016

Note:

1. Controlling Dimension: MM
2. Drawing is not to scale

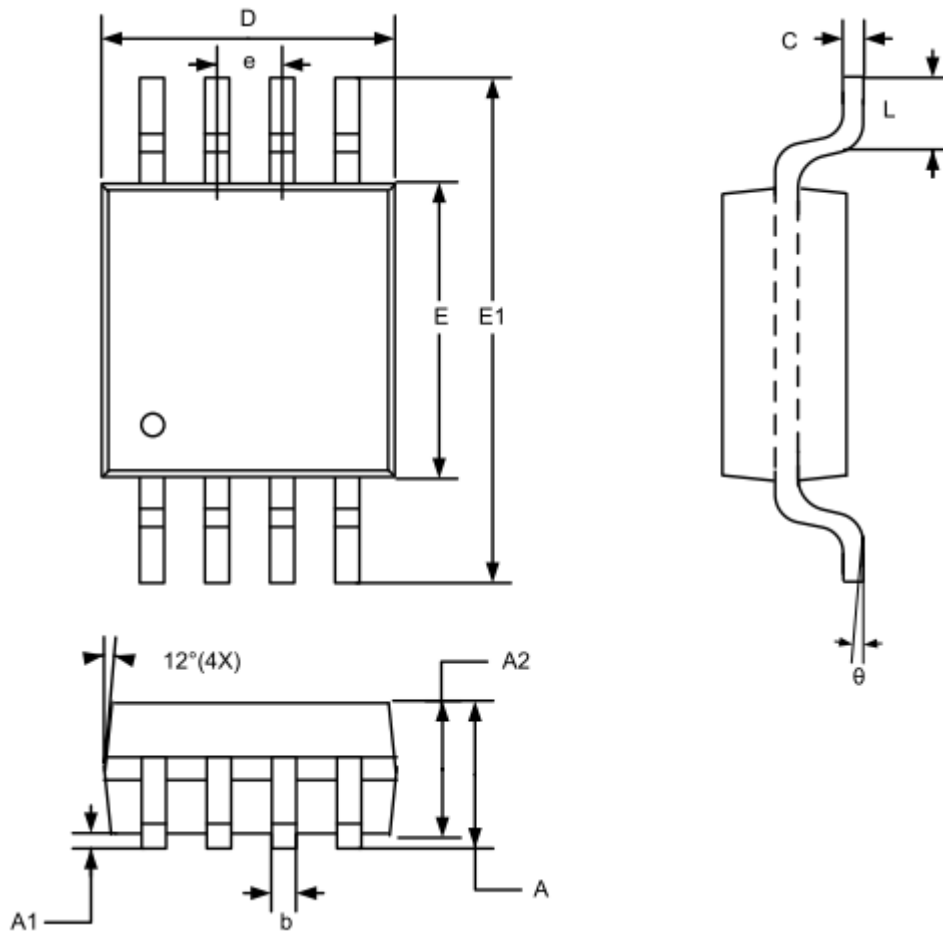
64K bits Two-wire Serial EEPROM
MSOP 8L

SYMBOLS	DIMENSIONS IN MILLIMETERS			DIMENSIONS IN INCHES		
	MIN	NOM	MAX	MIN	NOM	MAX
A	--	--	1.10	--	--	0.043
A1	0.05	--	0.15	0.002	--	0.006
A2	0.75	0.85	0.95	0.030	0.033	0.037
b	0.25	--	0.40	0.010	--	0.016
C	0.13	--	0.23	0.005	--	0.009
D	2.90	3.00	3.10	0.114	0.118	0.122
E	2.90	3.00	3.10	0.114	0.118	0.122
E1	4.90 BSC			0.193 BSC		
e	0.65 BSC			0.026 BSC		
L	--	--	0.55	--	--	0.022
Θ	0	--	7°	0	--	7°

Note:

1. Controlling Dimension: MM
2. Dimension D and E do not include Mold protrusion
3. Refer to Jedec standard MO187
4. Drawing is not to scale