

General Description

The EC3292B is a high efficiency synchronous step-down DC/DC converter series with 2A continuous output current supplied. Included on the substrate with the features listed is a high performance trans-conductance error amplifier that provides tight voltage regulation and accuracy under transient conditions. A built-in Under Voltage Lockout (UVLO) circuit is provided to prevent start-up until the input voltage reaches to 4.5V. In addition, it features over-current protection and thermal shutdown. To improve the light load efficiency, it is designed as the power saving mode (PSM) to minimize the switching loss by reducing the switching frequency. The EC3292B is available in SOT23-6L package.

Application

- ◆ Data comm. DSL CPE Graphics Cards
- ◆ Set-Top-Box, DVD
- ◆ Servers/Networking
- ◆ DSP and FPGA Power Supply

Features

- ◆ Input Voltage Supply Range from 4.5V to 18V
- ◆ Power Saving Mode (PSM) during the light Load Operation
- ◆ High Efficiency up to 95%
- ◆ Adjustable Output Voltage from 0.6V to 12V
- ◆ 2A Continuous Output Current
- ◆ 500KHz Constant Frequency Operation
- ◆ Current Mode Operation
- ◆ Programmable Soft-Start
- ◆ Over-temperature Protection
- ◆ Over-current Protection
- ◆ Input Under Voltage Lockout (UVLO)
- ◆ 10 μ A Shutdown Current
- ◆ SOT23-6L Package
- ◆ RoHS Compliant (100% Green Available)

- ◆ Telecomm Equipments
- ◆ DC-DC Regulator Modules
- ◆ LCD Monitor and LCD TV

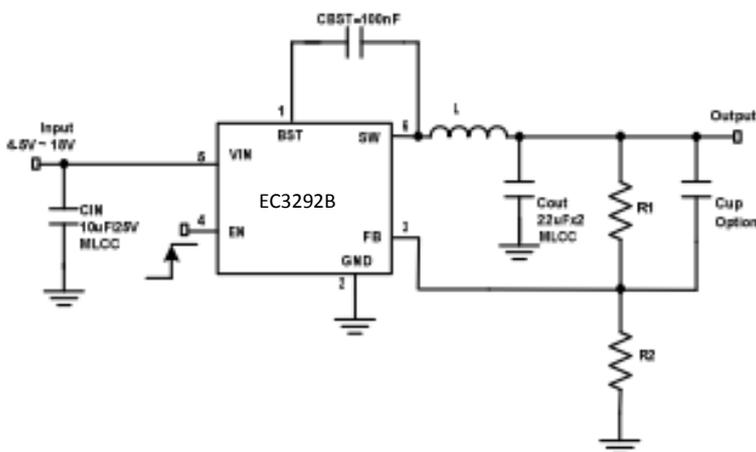
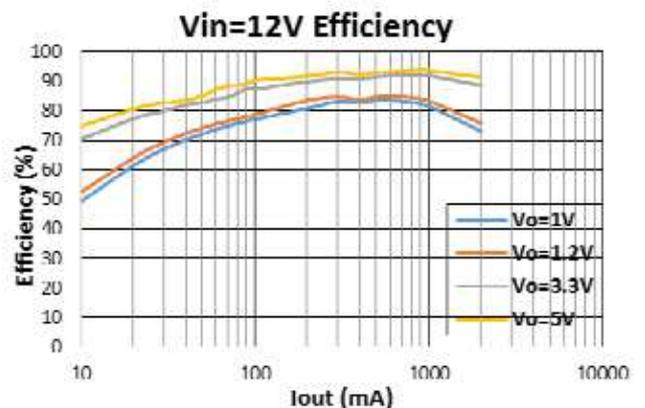
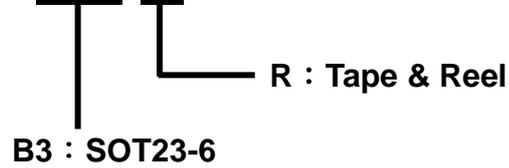

Figure 1. EC3292B Typical Operating Circuit



Ordering Information

EC3292BN XX X



B3 : SOT23-6

R : Tape & Reel

Part Number	Package	Marking	Marking Information
EC3292BNB3R	SOT23-6L	76321 XYWWX	1. Y : Year, 2. WW : Week 3. X : Internal Track Code

Pin Configuration

EC3292B Top View

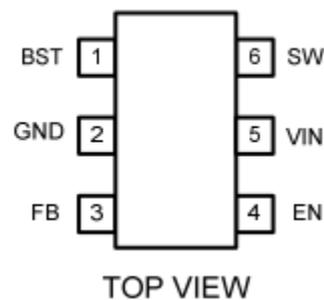

Pin Description

Pin No.	Symbol	Description
1	BST	High Side Gate Drive Boost Input It is required to connect SW and BST by a capacitor, which is able to boost the gate drive to the internal NMOS above VIN to fully turn it ON.
2	GND	Ground This is the reference of the ground connection for all components in the power supply.
3	FB	Voltage Feedback This is the input to an error amplifier, which drives the PWM controller. It is necessary to connect this pin to the actual output of power supply to set the DC output voltage.
4	EN	Enable (floating of this pin not recommended) This input provides an electrical ON/OFF control of the power supply.
5	VIN	Power Supply The input voltage for the power supply is connected to this pin.
6	SW	Power Switch Output This is the output of a power MOSFET switch.



Absolute Maximum Ratings (Note 1)

Input Supply Voltage	+21V
SW Voltage	- 1V to 22V
<10nS	(-5V to 25V)
EN Voltage	- 0.3 to VIN+0.3V
ESD Classification	Class 2
Junction Temperature Range	-40oC to 150°C
Storage Temperature Range	-65oC to 150°C
Lead Temperature (Soldering10s)	260°C
Other Pins	- 0.3V to +6V
Boost Voltage	Vsw+6V

Thermal Information (Note 3、4)

Maximum Power Dissipation(TA=+25°C)	0.8W	Thermal resistance(θJA)	125°C/W
		Thermal resistance(θJC)	66°C/W

Recommended Operating Conditions(Note 2)

Input Voltage (VIN)	+4.5V to +18V	Operating Temperature Range	-40°C to +85°C
		Junction Temperature Range	<+135°C

Note (1): Stress exceeding those listed “Absolute Maximum Ratings” may damage the device.

Note (2): The device is not guaranteed to function outside of the recommended operating conditions.

Note (3): Measured on JESD51-7, 4-Layer PCB.

Note (4): The maximum allowable power dissipation is a function of the maximum junction temperature TJ_MAX, the junction to ambient thermal resistance θJA, and the ambient temperature TA. The maximum allowable continuous power dissipation at any ambient temperature is calculated by PD_MAX= (TJ_MAX-TA)/θJA. Exceeding the maximum allowable power dissipation will cause excessive die temperature, and the regulator will go into thermal shutdown. Internal thermal shutdown circuitry protects the device from permanent damage.

Electrical Characteristics

$T_A = +25^{\circ}\text{C}$, $V_{IN} = 12\text{V}$, unless otherwise noted.

Parameter	Conditions	Min.	Typ.	Max.	Unit
Supply Voltage		4.5		18	V
Shutdown Supply Current	$V_{EN} = 0\text{V}$		10		μA
Regulated Feedback Voltage	$4.5\text{V} \leq V_{IN} \leq 18\text{V}$	0.584	0.6	0.616	V
Current Limit	$V_O = 1\text{V}$		3.5		A
SW Leakage Current	$V_{EN} = 0\text{V}$, $V_{SW} = 0\text{V}$			10	μA
High Side On Resistance			0.12		Ω
Low Side On Resistance			0.08		Ω
Oscillation Frequency		400	500	600	MHz
Short Circuit Oscillation Frequency	$V_{FB} = 0\text{V}$		167		kHz
Maximum Duty Cycle	$V_{FB} = 0.5\text{V}$		90		%
Minimum Duty Cycle	$V_{FB} = 1.2\text{V}$			0	%
Minimum On Time			100		ns
Under Voltage Lockout Threshold	V_{IN} Rising	3.85	4.1	4.35	V
Under Voltage Lockout Threshold Hysteresis			250		mV
Thermal Shutdown Threshold			155		$^{\circ}\text{C}$
EN High Level		2.8			V
EN Low Level				0.6	V
EN Input Current	$V_{EN} = 0\text{V}$			14	μA

Functional Block Diagram

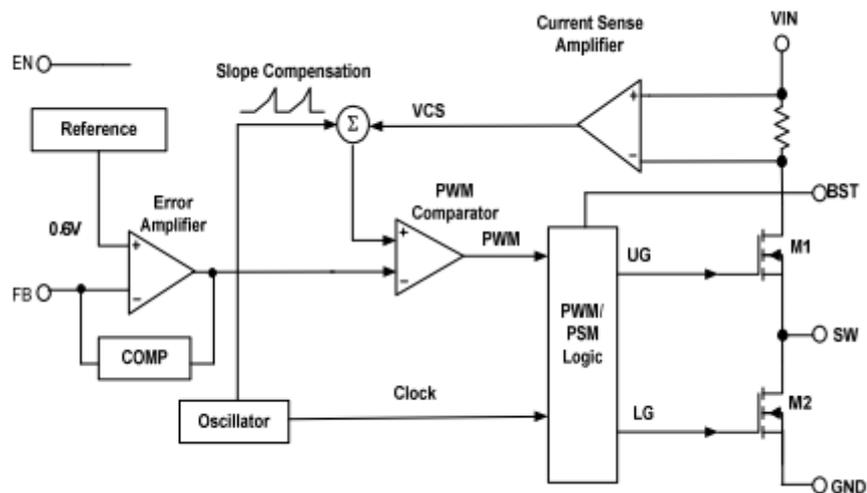
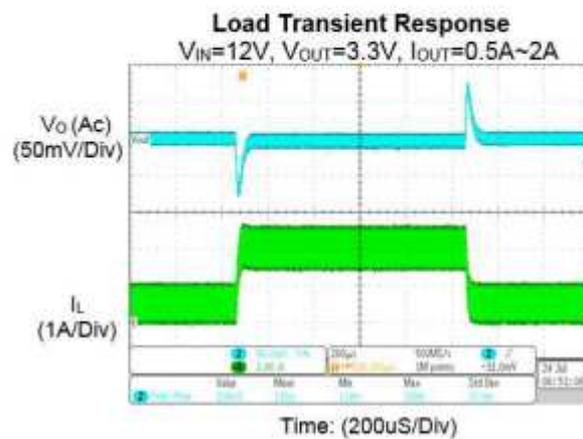
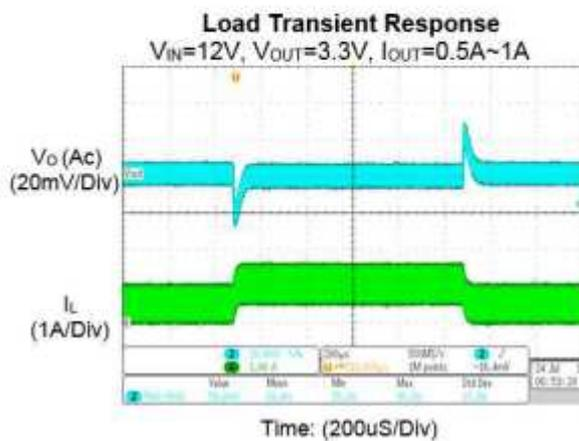
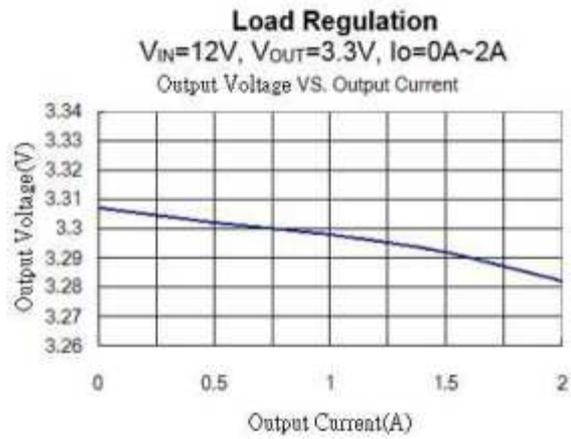
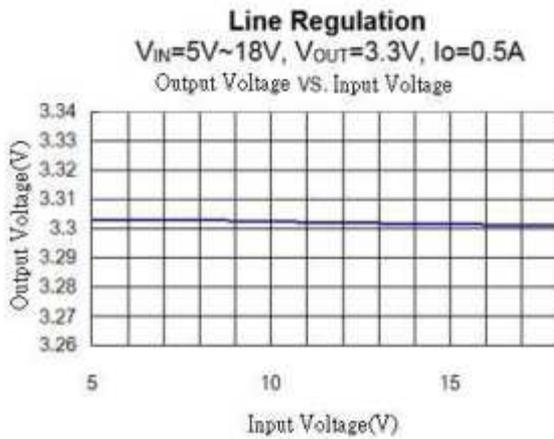
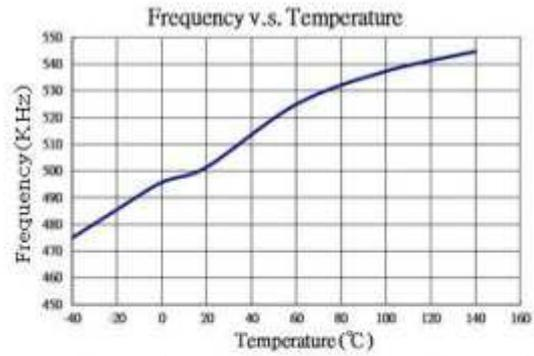
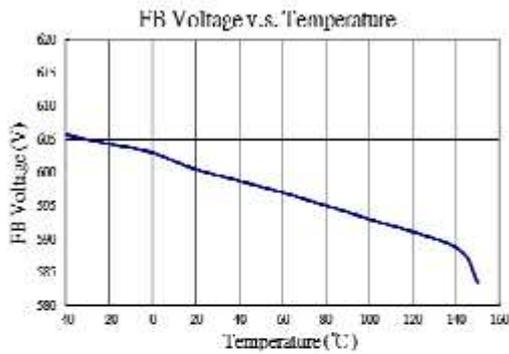
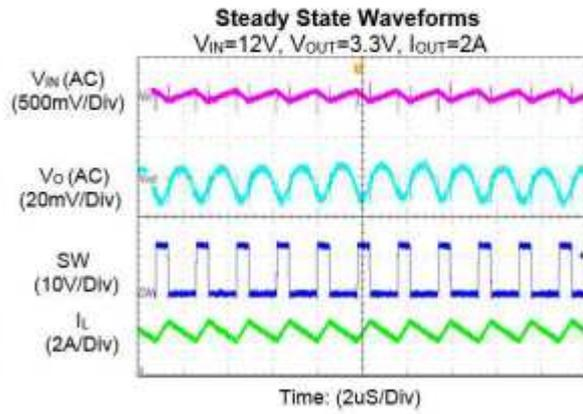
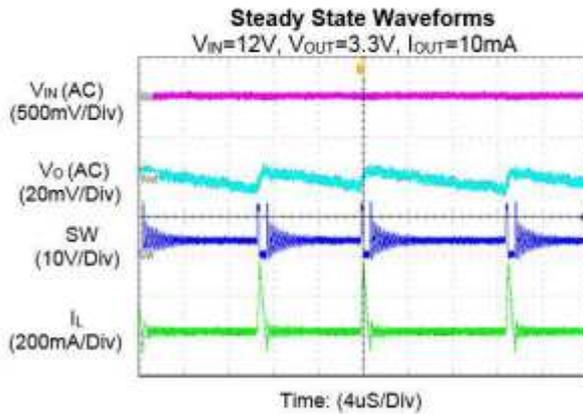
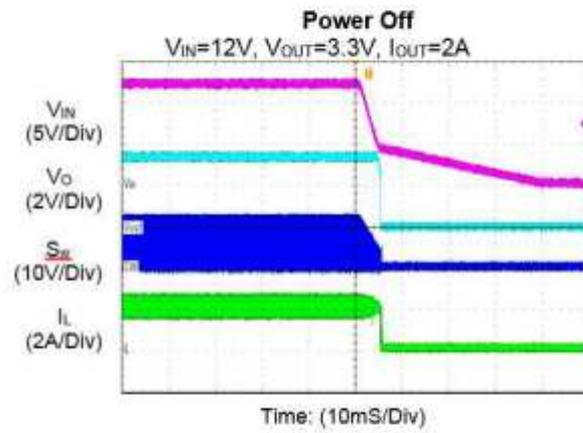
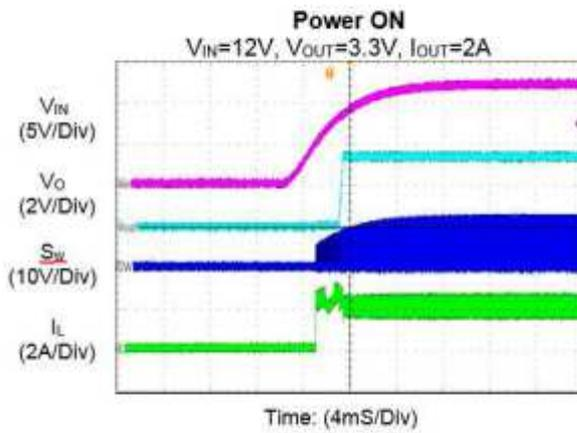
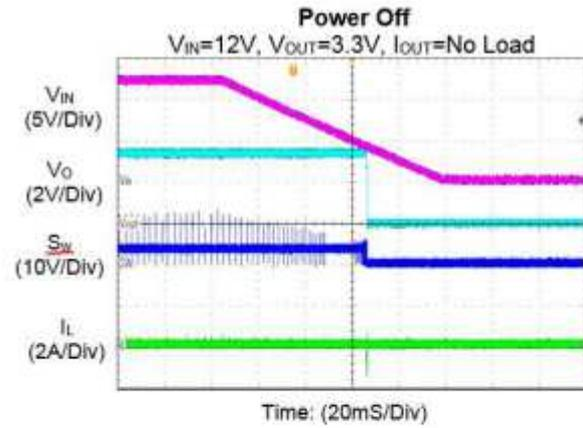
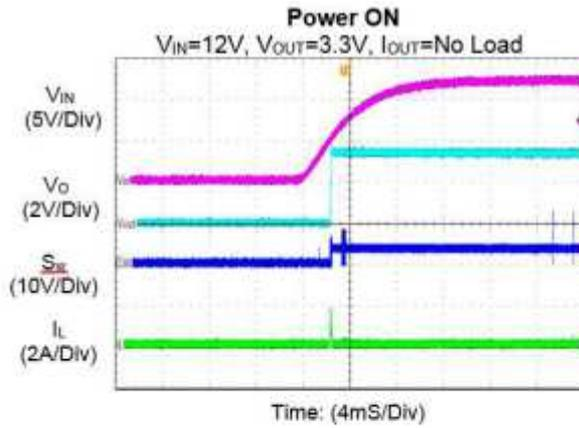

Figure 2. EC3292B Functional Block Diagram

Typical Performance Characteristics

$V_{IN}=12V$, $C_{IN}=10\mu F$, $C_{OUT}=22\mu F \times 2$, $T_A=+25^\circ C$







Detailed Description

The part is a current mode PWM synchronous step-down converter with a constant switching frequency. It regulates the input voltage from 4.5V to 18V and a low output voltage of 0.6V. The supplied load current is up to 2A.

Power Saving Mode

The switching losses resulted from the Miller capacitance of the MOSFET are the dominant power dissipation parameters at light load. The power saving mode at light load can minimize the switching loss by reducing the switching frequency. Therefore, the part is designed as the power saving mode for high efficiency at light load.

Oscillator Frequency

Slope compensated current mode PWM control provides not only stable switching and cycle-by-cycle current limit for superior load and line response but also protection of the internal main switch and synchronous rectifier. The part switches at a constant frequency (500KHz) and regulates the output voltage. The PWM comparator modulates the power transferred to the load by changing the inductor's peak current based on the feedback error voltage during each cycle. The main switch is turned on for a certain period to ramp the inductor's current at each rising edge of the internal oscillator under normal operation whereas off when the inductor's peak current is above the error voltage. After the main switch is turned off, the low side MOS will be turned on immediately and stay on until the next cycle starts.

Short Circuit Protection

The part provides short circuit protection. When the output is shorted to ground, the oscillator's frequency is reduced to prevent the inductor's current from increasing beyond the NMOS current limit. The NMOS current limit is also reduced to lower the short circuit current. The frequency and current limit will return to the normal values once the short circuit condition is removed and the feedback voltage reaches 0.6V.

Maximum Load current

The part can operate down to 4.5V input voltage; however the maximum load current decreases at lower input due to large IR voltage drop on the main switch and low side switch. The slope compensation signal reduces the inductor's peak current as a function of the duty cycle to prevent sub-harmonic oscillations at duty cycles greater than 50%.

Enable

The EN pin provides electrical on/off control of the regulator. Once the voltage of the EN pin exceeds the threshold voltage, the regulator starts operation and the internal slow start begins to ramp. If the voltage of the EN pin is pulled below the threshold, the regulator will stop switching and the internal slow start reset. If the EN pin is open, it will be pulled to high by the internal circuit.

Under Voltage Lockout

The part incorporates an under voltage lockout circuit to keep the device disabled when V_{IN} is below the UVLO start threshold. During power-up, the internal circuit is held inactive until V_{IN} exceeds the UVLO start threshold voltage. Once this threshold voltage is reached, device start-up begins. The device operates until V_{IN} falls below the UVLO stop threshold voltage. The typical hysteretic in the UVLO comparator is 250mV.

Boost Capacitor

The BST pin and SW pin can be connected by a 100nF low ESR ceramic capacitor, providing the gate drive voltage for the high side MOSFET.

Thermal Shutdown

The part protects itself from overheating with an internal thermal shutdown circuit. If the junction temperature exceeds the thermal shutdown threshold, the voltage reference will be grounded and high side MOSFET turned off.

Application Information

Input Capacitor Selection

It is necessary for the input capacitor to sustain the ripple current produced during the period of “on” state of the upper MOSFET, so a low ESR is required to minimize the loss. The RMS value of this ripple can be obtained by the following:

$$I_{IN\text{RMS}} = I_{OUT} \sqrt{D \times (1 - D)}$$

Where D is the duty cycle, $I_{IN\text{RMS}}$ is the input RMS current, and I_{OUT} is the load current. The equation reaches its maximum value with $D = 0.5$. The loss of the input capacitor can be calculated by the following equation:

$$P_{CIN} = ESR_{CIN} \times I_{IN\text{RMS}}^2$$

Where P_{CIN} is the power loss of the input capacitor and ESR_{CIN} is the effective series resistance of the input capacitance. Due to large di/dt through the input capacitor, electrolytic or ceramics should be used. If a tantalum must be used, it must be surge-protected. Otherwise, capacitor failure could occur.

Output Inductor Selection

The output inductor selection is to meet the requirements of the output voltage ripple and affects the load transient response. The higher inductance can reduce the inductor's ripple current and induce the lower output ripple voltage. The ripple voltage and current can be approximately calculated approximated by the following equations:

$$\Delta I = \frac{V_{in} - V_{out}}{F_S \times L} \cdot \frac{V_{out}}{V_{in}}$$

$$\Delta V_{out} = \Delta I \times ESR$$

Although the increase of the inductance reduces the ripple current and voltage, it contributes to the decrease of the response time for the regulator to load transient as well. Increasing the switching frequency (F_s) for a given inductor also can reduce the ripple current and voltage but it will increase the switching loss of the power MOS.

The way to set a proper inductor value is to have the ripple current (ΔI) be approximately 10%~50% of the maximum output current. Once the value has been determined, select an inductor capable of carrying the required peak current without going into saturation. It is also important to have the inductance tolerance specified to keep the accuracy of the system controlled. Using 20% for the inductance (at room temperature) is reasonable tolerance able to be met by most manufacturers. For some types of inductors, especially those with core made of ferrite, the ripple current will increase abruptly when it saturates, resulting in a larger output ripple voltage.

Output Capacitors Selection

An output capacitor is required to filter the output and supply the load transient current. The high capacitor value and low ESR will reduce the output ripple and the load transient drop. These requirements can be met by a mix of capacitors and careful layout.

In typical switching regulator design, the ESR of the output capacitor bank dominates the transient response. The number of output capacitors can be determined by the following equations:

$$ESR_{MAX} = \frac{\Delta V_{ESR}}{\Delta I_{OUT}}$$

$$\text{Number Of Capacitors} = \frac{ESR_{CAP}}{ESR_{MAX}}$$

V_{ESR} = change in output voltage due to ESR

I_{OUT} = load transient.

ESR_{CAP} = maximum ESR per capacitor (specified in manufacturer's data sheet).

ESR_{MAX} = maximum allowable ESR.

High frequency decoupling capacitors should be placed as close to the power pins of the load as physically possible. For the decoupling requirements, please consult the capacitor manufacturers for confirmation.

Output Voltage

The output voltage is set using the FB pin and a T-type resistor connected to the output as the circuit shown below.

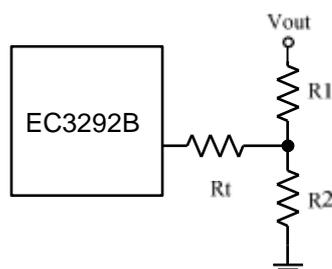

The output voltage (V_{out}) can be calculated according to the voltage of the FB pin (V_{FB}) and ratio of the feedback resistors by the following equation, where (V_{FB}) is 0.6V:

$$V_{out} = 0.6 \times \frac{(R_1 + R_2)}{R_2}$$

R_1 and R_t can set the loop gain bandwidth. The recommended T-type resistor values for AP circuit are as the table below. Choose R_1 around 10K Ω and R_2 can be obtained by:

$$R_2 = \frac{R_1}{\frac{V_{out}}{0.6V} - 1}$$

(Recommended component values without R_t)

Application 1 (Typical) without R_t				
V_{out}	L (uH)	R_1 (K Ω)	R_2 (K Ω)	R_t (K Ω)
1	4.7	86.6 (1%)	130 (1%)	0
1.2	4.7	86.6 (1%)	86.6 (1%)	0
1.5	4.7	86.6 (1%)	57.6 (1%)	0
1.8	4.7	86.6 (1%)	43.2 (1%)	0
2.5	6.8	86.6 (1%)	27.4 (1%)	0
3.3	6.8	86.6 (1%)	19.1 (1%)	0
5	6.8	86.6 (1%)	11.8 (1%)	0

(Recommended T-type resistor values with R_t)

V_{out} (V)	L (uH)	R_1 (K Ω)	R_2 (K Ω)	R_t (K Ω)
1	4.7	10 (1%)	15 (1%)	40.2 (1%)
1.2	4.7	10 (1%)	10 (1%)	34 (1%)
1.5	4.7	10 (1%)	6.65 (1%)	27.4 (1%)
1.8	4.7	10 (1%)	5 (1%)	23.2 (1%)
2.5	6.8	10 (1%)	3.16 (1%)	16.9 (1%)
3.3	6.8	10 (1%)	2.21 (1%)	13.3 (1%)
5	6.8	10 (1%)	1.37 (1%)	9.1 (1%)

External Bootstrap Diode

When the condition Duty Cycle > 65% occurs, it is strongly recommended to add an external bootstrap diode (such as IN4148 or BAT54) between an external 5V and BST pin for efficiency improvement. The external 5V should be lower than 5.5V.

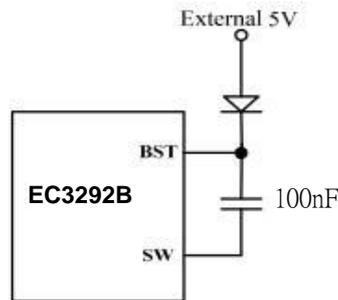

Layout Consideration

For proper operation of the converter, some layout rules should be followed. It is necessary to understand which pin of EC3292B is sensitive and which is insensitive. Please refer the following for the location where noise comes from on the circuit and where the clear ground is for the small signal ground.

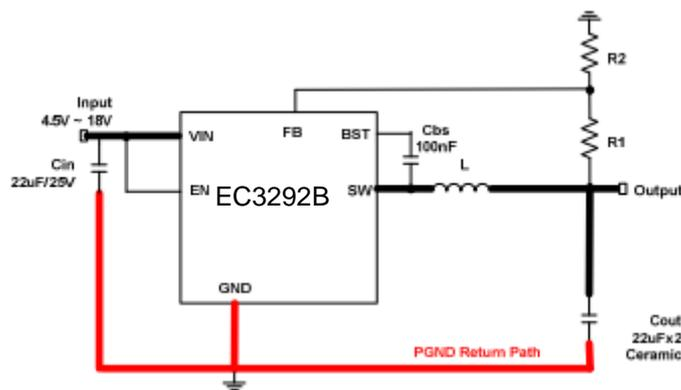

- 1.) First, put the input capacitor (C_{IN}) as close as possible to the VIN pin.
- 2.) Secondly, place the C_s, R_s, C_p, C_{SS} and R₂ as close as EC3292B and connect these analog grounds (Clear AGND) to EC3292B's GND pin. It is recommended to use a dot short for these AGND pins or connect the GND pin via contact.
- 3.) The large current loop shown in bold lines in the above figure circuit should be routed as short and wide as possible and the switch node is a high dv/dt. It easily couples noise to other traces by the capacitive path. Therefore the sensitive signals like FB, COMP and AGND should be routed away with this noise source.
- 4.) The feedback network resistors (R₁ & R₂) should be routed away from the inductor and switch node to minimize noise and EMI issue. And the R₁ resistor should be sensed the output capacitor or device loading, not the inductor's output node.

Application: Typical Application Circuit

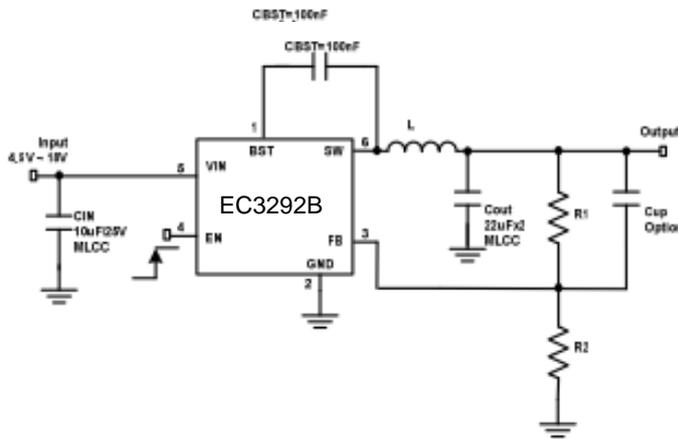

Vout (V)	L (uH)	R1 (KΩ)	R2 (KΩ)
1	4.7	86.6	130
1.2	4.7	86.6	86.6
1.5	4.7	86.6	57.6
1.8	4.7	86.6	43.2
2.5	6.8	86.6	27.4
3.3	6.8	86.6	19.1
5	6.8	86.6	11.8

Use 1% Resistor

Qty	Ref	Value	Description	Package
2	Cout	22μF	Ceramic Capacitor X5R 16V Murata-part number: GRM32ER61C226KE20L	1206
1	CIN	10uF	Ceramic Capacitor X5R 25V	1206
1	CBST	100nF	Ceramic Capacitor	0603
1	L	4.7u~6.8uH	Inductor, Rated Current 3.5A TDK:APM6530T WE:74477 CYNTEC:PCMB104T	SMD
1	U1	EC3292B	Step-Down DC/DC Converter	SOT23_6L

Application 2: (Cout=22uFx2 MLCC with Rt)

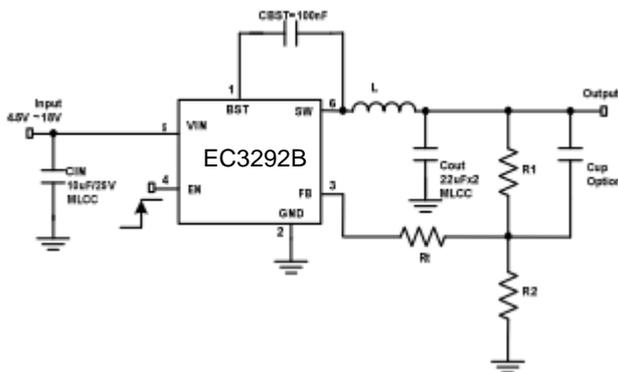

Vout (V)	L (uH)	R1 (KΩ)	R2 (KΩ)	Rt (KΩ)
1	4.7	10	15	40.2
1.2	4.7	10	10	34
1.5	4.7	10	6.65	27.4
1.8	4.7	10	5	23.2
2.5	6.8	10	3.16	16.9
3.3	6.8	10	2.21	13.3
5	6.8	10	1.37	9.1

Use 1% Resistor

Qty	Ref	Value	Description	Package
2	Cout	22 μ F	Ceramic Capacitor X5R 16V Murata-part number: GRM32ER61C226KE20L	1206
1	CIN	10 μ F	Ceramic Capacitor X5R 25V	1206
1	CBST	100nF	Ceramic Capacitor	0603
1	L	4.7~6.8 μ H	Inductor, Rated Current 3.5A TDK:APM6530T WE:74477 CYNTEC:PCMB104T	SMD
1	U1	EC3292B	Step-Down DC/DC Converter	SOT23_6L

Application 3: (Cout=22 μ Fx1 MLCC with Rt)

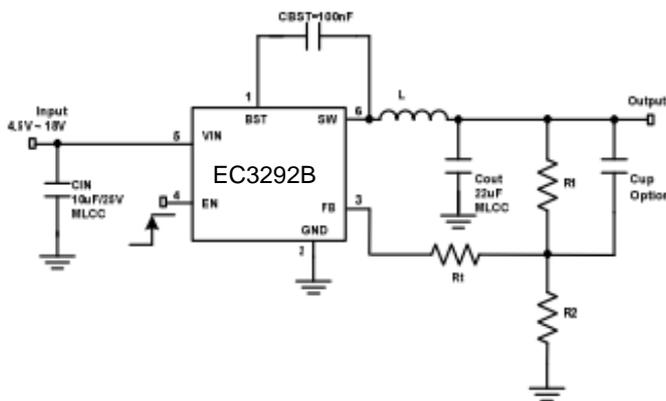

Vout (V)	L (μ H)	R1 (K Ω)	R2 (K Ω)	Rt (K Ω)
1	4.7	10	15	86.6
1.2	4.7	10	10	73.2
1.5	4.7	10	6.65	59
1.8	4.7	10	5	49.9
2.5	6.8	10	3.16	36.5
3.3	6.8	10	2.21	28.7
5	6.8	10	1.37	19.6

Use 1% Resistor

Qty	Ref	Value	Description	Package
1	Cout	22 μ F	Ceramic Capacitor X5R 16V Murata-part number: GRM32ER61C226KE20L	1206
1	CIN	10 μ F	Ceramic Capacitor X5R 25V	1206
1	CBST	100nF	Ceramic Capacitor	0603
1	L	4.7~6.8 μ H	Inductor, Rated Current 3.5A TDK:APM6530T WE:74477 CYNTEC:PCMB104T	SMD
1	U1	EC3292B	Step-Down DC/DC Converter	SOT23_6L

Package Information

SOT23-6L Package Outline Dimension

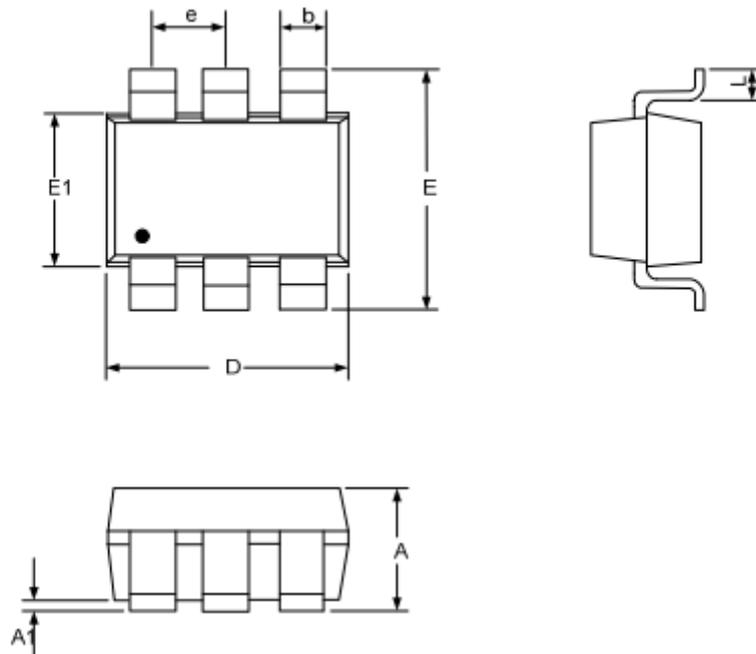

SYMBOLS	MILLIMETERS		INCHES	
	MIN.	MAX.	MIN.	MAX.
A	-	1.45	-	0.057
A1	0.00	0.15	0.000	0.006
b	0.30	0.50	0.012	0.020
D	2.90		0.114	
E1	1.60		0.063	
e	0.95		0.037	
E	2.60	3.00	0.102	0.118
L	0.30	0.60	0.012	0.024