



General Description

EGM2576HV series is designed to provide all the active function for a step-down (buck) switching regulator, and drives a maximum load current as high as 3A line and load regulations. EGM2576HV is available in fixed output voltages of 3.3V, 5V, and a versatile Adjustable output version.

These regulators are simple to use and require minimum number of external components. The features include internal frequency compensation and a fixed-frequency oscillator.

The EGM2576HV is high-efficiency replacements for popular three-terminal linear regulators, and is requiring a smaller heat sink or even no need heat sink.

EGM2576HV performs well with standard inductors from most of manufacturers, and simplifying the design of switch-mode power supplies. External shutdown is included with 80 μ A (typical) standby current. The output switch has cycle-by-cycle current limiting as well as thermal shutdown for full protection under fault conditions.

EGM2576HV operates at a switching frequency of 52 kHz which allowing smaller size filter components than what would be needed with lower frequency switching regulators.

EGM2576HV series are available in a standard 8 lead SOP package with heat sink

Features

- Standard SOP8 package is available
- 3.3V, 5V, and Adjustable output versions
- Adjustable version output voltage range 1.23V to 57V
- Input voltage range up to 60V
- Requires only 4 external components with High efficiency
- TTL shutdown capability, low power standby mode
- Built-in thermal shutdown, current limit protection
- Uses standard inductors
- 52 kHz fixed frequency internal oscillator

Applications

- Pre-regulator for linear regulators
- High-efficiency step-down buck regulator
- On-card/board switching regulators
- Positive to negative converter (buck-boost)

Typical Application Circuits

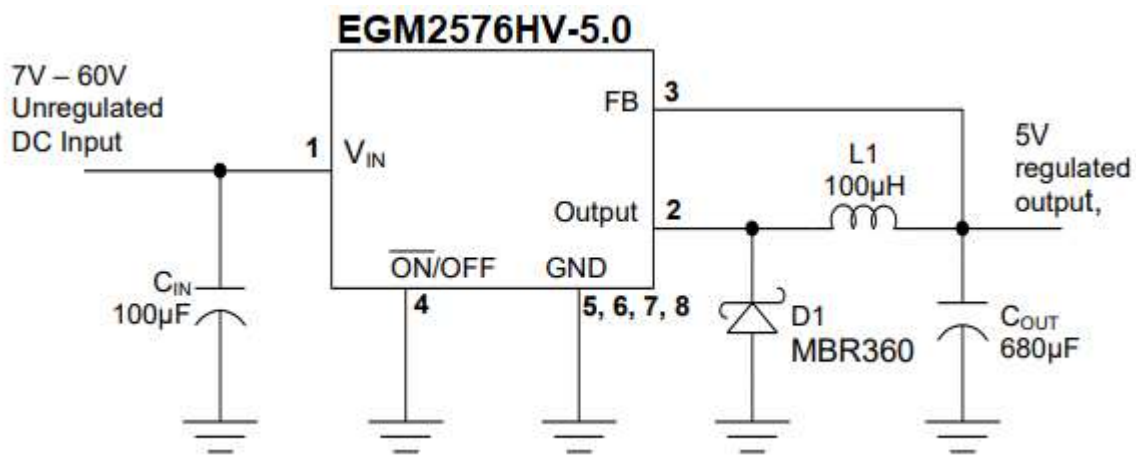

Marking Information and Pin Configurations (Top View)

SOP8

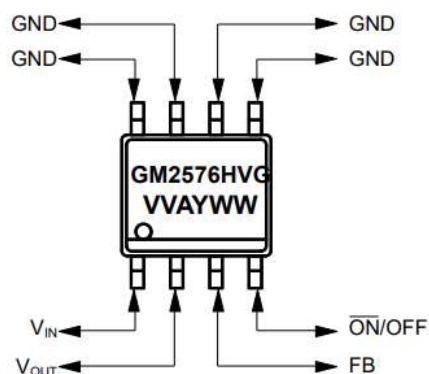

G: Green Product
 VV: 33=3.3V, 50=5.0V, A=ADJ
 A: Assembly/Testing factory code
 Y: Year
 WW: Week

Ordering Information

Ordering Number	Output Voltage	Package	Shipping
EGM2576HV-ADJM1GR	Adj	SOP8	2500 Units / Reel
EGM2576HV-33M1GR	3.3	SOP8	2500 Units / Reel
EGM2576HV-50M1GR	5.0	SOP8	2500 Units / Reel

Absolute Maximum Ratings (Note 1)

Rating	Value	Unit
Maximum Supply Voltage	63	V
ON/OFF Pin Input Voltage / Feed Back Pin Voltage	-0.3 to $V_{IN} + 0.3$	V
Output Voltage to Ground (Steady State)	-0.75	V
Power Dissipation	Internally Limited	-
Thermal Resistance – Junction to Ambient (θ_{JA}) <small>** 2 square inch of FR-4, double sided, 1oz. minimum copper weight, is recommended</small>	36	$^{\circ}\text{C}/\text{W}$
Storage Temperature Range	- 65 to 150	$^{\circ}\text{C}$
Maximum Junction Temperature	+ 150	$^{\circ}\text{C}$
Operating Temperature Range	- 40 to 125	$^{\circ}\text{C}$
Minimum EDS Rating (Note 2)	2	kV
Lead Temperature (Soldering, 10 sec)	+ 260	$^{\circ}\text{C}$

Block Diagram

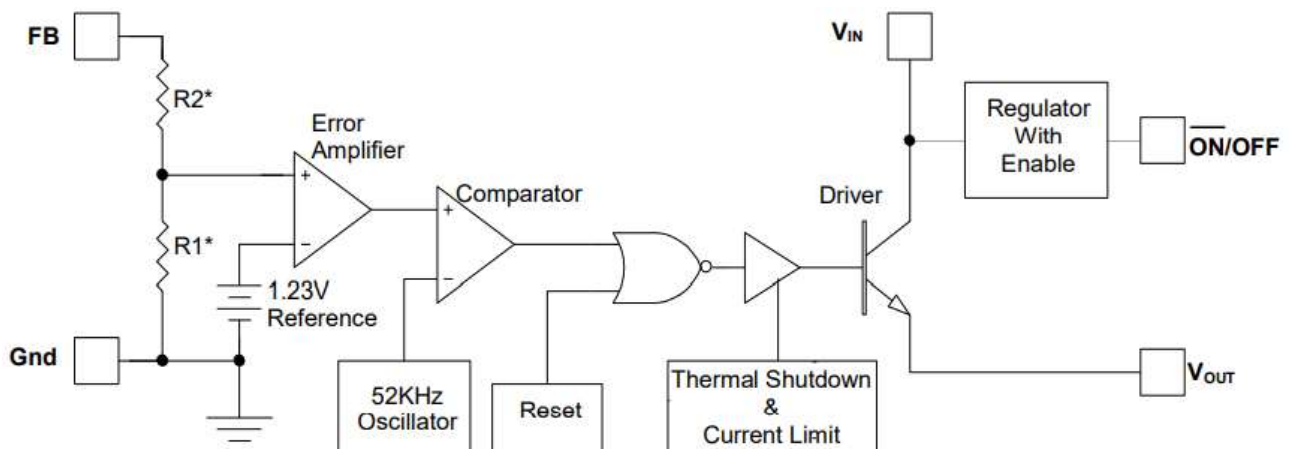

$V_{OUT} = 3.3\text{V}$, $R1 = 1\text{K}$, $R2 = 1.7\text{K}$
 $V_{OUT} = 5.0\text{V}$, $R1 = 1\text{K}$, $R2 = 3.1\text{K}$
 $V_{OUT} = \text{ADJ}$, $R1 = \text{OPEN}$, $R2 = 0\Omega$



60V/3A STEP DOWN VOLTAGE SWITCHING REGULATORS

EGM2576HV

Electrical Characteristics: EGM2576HV-ADJ

(Specifications with standard type face are for T = 25°C, and those with bold face type apply over full Operating Temperature range)

Parameter	Condition	Symbol	Min	Typ	Max	Unit
Feedback Voltage	$V_{IN} = 12V, I_{LOAD} = 0.2A, V_{OUT}$ is set to 5V	V_{FB}	1.217	1.230	1.243	V
	$8.0V \leq V_{IN} \leq 60V, 0.2A \leq I_{LOAD} \leq 3A, V_{OUT}$ is set to 5V		1.193	1.230	1.267	
			1.180		1.280	
Efficiency	$V_{IN} = 12V, I_{LOAD} = 3.0A, V_{OUT} = 5V$	η		77		%

Electrical Characteristics: EGM2576HV-33

(Specifications with standard type face are for T = 25°C, and those with bold face type apply over full Operating Temperature range)

Parameter	Condition	Symbol	Min	Typ	Max	Unit
Output Voltage	$V_{IN} = 12V, I_{LOAD} = 0.5A$	V_{OUT}	3.234	3.300	3.366	V
	$6.0V \leq V_{IN} \leq 60V, 0.2A \leq I_{LOAD} \leq 3A$		3.168		3.432	
			3.135		3.465	
Efficiency	$V_{IN} = 12V, I_{LOAD} = 3.0A,$	η		75		%

Electrical Characteristics: EGM2576HV-50

(Specifications with standard type face are for T = 25°C, and those with bold face type apply over full Operating Temperature range)

Parameter	Condition	Symbol	Min	Typ	Max	Unit
Output Voltage	$V_{IN} = 12V, I_{LOAD} = 0.5A$	V_{OUT}	4.900	5.000	5.100	V
	$8.0V \leq V_{IN} \leq 60V, 0.2A \leq I_{LOAD} \leq 3A$		4.800		5.200	
			4.750		5.250	
Efficiency	$V_{IN} = 12V, I_{LOAD} = 3.0A$	η		77		%



60V/3A STEP DOWN VOLTAGE SWITCHING REGULATORS

EGM2576HV

Electrical Characteristics: All Output Voltage Versions

(Specifications with standard type face are for $T = 25^{\circ}\text{C}$, and those with bold face type apply over full Operating Temperature range, $V_{IN} = 12\text{V}$)

Parameter	Condition	Symbol	Min	Typ	Max	Unit
Feedback Bias Current	$V_{OUT} = 5\text{V}$ (Adjustable Version Only)	I_b	-	50	100	nA
					500	
Oscillator Frequency	(Note 3)	f_o	42	52	63	kHz
Saturation Voltage	$I_{OUT} = 3\text{A}$ (Notes 4, 5)	V_{SAT}	-	1.4	1.55	V
					1.70	
Max Duty Cycle (ON)	(Note 5)	DC	93	98	-	%
Current Limit	Peak Current (Notes 4, 5)	I_{CL}	4.2	5.8	6.9	A
			3.5		7.5	
Output Leakage Current	Output = 0V (Notes 4, 6)	I_L	-	7.5	2	mA
	Output = -0.75V (Notes 4, 6)				30	
Quiescent Current	(Note 6)	I_Q	-	5	10	mA
Standby Quiescent Current	ON/OFF Pin = 5V (OFF), $V_{IN} = 60\text{V}$	I_{STBY}	-	50	200	μA
ON/OFF Pin Logic Input Level	Low (ON)	V_{IH}	-	1.2	1.0	V
					0.8	
	High (OFF)	V_{IL}	2.2	1.4	-	
			2.4			
ON/OFF Pin Input Current	$V_{LOGIC} = 2.5\text{V}$ (OFF)	I_H		12	30	μA
	$V_{LOGIC} = 0.5\text{V}$ (ON)	I_L		0	10	

Note

- Stresses greater than those listed under Maximum Ratings may cause permanent damage to the device. This is a stress rating only and functional operation of the device at these or any other conditions above those indicated in the operation is not implied. Exposure to absolute maximum rating conditions for extended periods may affect reliability.
- The human body model is a 100pF capacitor discharge through a 1.5K Ω resistor into each pin.
- External components such as the catch diode, inductor, input and output capacitors, and voltage programming resistors can affect switching regulator system performance. Where the EGM2576HV is used as shown in Figure 1&2 test circuits.
- No diode, inductor or capacitor connected to output pin.
- Feedback pin removed from output and connected to 0V to force the output transistor switch ON.
- Feedback pin removed from output and connected to 12V for the 3.V, 5V and Adj version, to force the output transistor switch OFF.

Test Circuit and Layout Guidelines

Careful layout is important with any switching regulators. Rapidly switching currents associated with wiring inductance generate voltage transients which can cause problems. To minimize inductance and ground loops, the lengths of the leads indicated by heavy lines in Figure 1&2 below should be kept as short as possible. Single point grounding (as indicated or ground plane construction should be used for best results. When using the Adjustable version, place the programming resistors as close as possible to EGM2576HV, to keep the sensitive feedback wiring short.

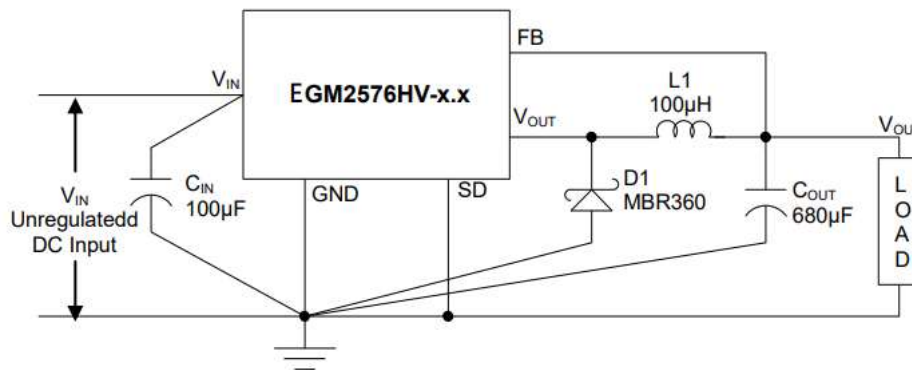

Figure 1 Fixed Output Voltage Versions

$C_{IN} = 100\mu\text{F}$, 75V Aluminum Electrolytic
 $C_{OUT} = 680\mu\text{F}$, 25V, Aluminum Electrolytic
 D1 = Schottky
 L1 = 100µH

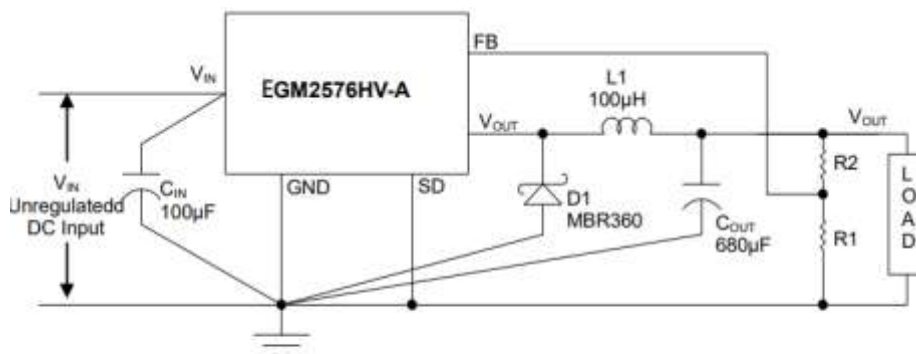

Figure 2 Adjustable Output Voltage Versions

$C_{IN} = 100\mu\text{F}$, 75V Aluminum Electrolytic
 $C_{OUT} = 680\mu\text{F}$, 25V, Aluminum Electrolytic
 D1 = Schottky
 L1 = 100µH

$$V_{OUT} = V_{REF} (1 + R2/R1)$$

where $V_{REF} = 1.23\text{V}$ and R1 is between 1K to 5K

Package Outline Dimensions – SOP8

