

General Description

The ELN74SZ08 is a 2-input CMOS AND Gate, manufactured using silicon gate CMOS fabrication. CMOS low power circuit operation makes high speed LS-TTL operation achievable.

With a wave forming buffer connected internally, stabilized output can be achieved as the circuit offers high noise immunity. As the ELN74SZ08 is integrated into mini molded, SOT-353 package, high density mounting is possible.

Features

- ◆ High speed operation : $t_{pd} = 2.6\text{ns}$ (TYP.)
- ◆ Operating voltage range : 1.2V ~ 6.0V
- ◆ Low power consumption : 1 μA (MAX.)
- ◆ CMOS and Gate
- ◆ Ultra small package : SOT-353

Applications

- ◆ Palmtops
- ◆ Digital equipment
- ◆ Portable electronic products

Package

- ◆ SOT-353



(Top View)

Functions

Input		Output
A	B	Y
L	L	L
L	H	L
H	L	L
H	H	H

H=High Level
L=Low Level

Pin Configuration

Pin Number	Pin Name	Function Description
1	B	Input B
2	A	Input A
3	GND	Ground
4	Y	Output Y
5	V _{cc}	Power supply

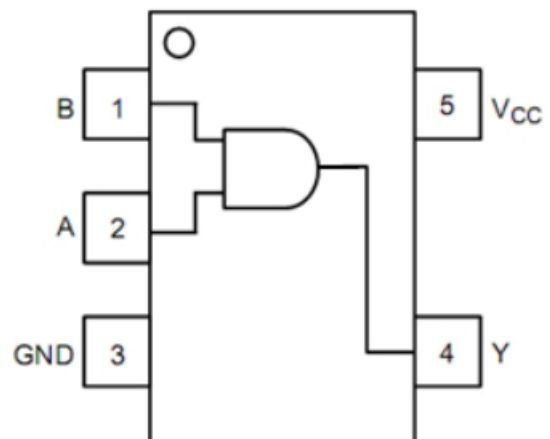

Fig 1. Pin Configuration



Ordering Information

Product name	function	Mark	Symbol
ELN74SZ08	2-input CMOS AND Gate	Z08	AND2

Absolute Maximum Ratings

Supply voltage	-0.5V to 7V
Output voltage	-0.5V to Vcc+0.3V
Input voltage	-0.5V to 7V
Output current	±25mA
Ground current	±50mA
Storage temperature range	-65°C to 150°C
Lead temperature(soldering)	260°C
Power dissipation PD (On PCB board , 25) SOT-353	150mW

Recommended Operating Environment

Supply voltage	2V to 5.5V
Output voltage	0V to VCC
Input voltage	0V to VCC
Operating temperature	-40°C to 85°C
Output current	±4mA@3V
Output current	±8mA@4.5V
Input signal rise and fall time	0-100ns/V@3.3V
Input signal rise and fall time	0-20ns/V@5.0V



Electrical Characteristics

Parameter	Symbol	Voltage(V)	Conditions	Ta=25°C			Ta=-40-85°C		Unit	
				Min	Typ	Max	Min	Max		
Input voltage	V _{IH}	1.2		0.9	—	—	0.9	—	V	
		2.0		1.5	—	—	1.5	—		
		3.0		2.1	—	—	2.1	—		
		5.5		3.85	—	—	3.85	—		
	V _{IL}	1.2		—	—	0.3	—	0.3	V	
		2.0		—	—	0.5	—	0.5		
		3.0		—	—	0.9	—	0.9		
		5.5		—	—	1.65	—	1.65		
Output voltage	V _{OH}	2.0	V _{IN} =V _{IH} Or V _{IN} =V _{IL}	I _{OH} =-50μA	1.9	2.0	—	1.9	—	V
		3.0			2.9	3.0	—	2.9	—	
		4.5		4.4	4.5	—	4.4	—		
		3.0		I _{OH} =-4mA	2.58	—	—	2.48	—	
	4.5	I _{OH} =-8mA	3.94	—	—	3.80	—			
	V _{OL}	2.0	V _{IN} =V _{IH}	I _{OH} =50μA	—	—	0.1	—	0.1	V
		3.0			—	—	0.1	—	0.1	
		4.5			—	—	0.1	—	0.1	
		3.0		I _{OH} =4mA	—	—	0.36	—	0.44	
		4.5		I _{OH} =8mA	—	—	0.36	—	0.44	
Input current	I _{IN}	0-5.5	V _{IN} =V _{CC} or GND	-0.1	—	0.1	-1.0	1.0	μA	
Quiescent current	I _{CC}	5.5	V _{IN} =V _{CC} or GND I _{OUT} =0μA	—	—	1	—	10	μA	
Delay time	t _{PLH}	3.3	C _L =15pF	—	3.7	8.8	1.0	10.5	nS	
			C _L =50pF	—	5.2	12.3	1.0	14.0		
		5.0	C _L =15pF	—	2.8	5.9	1.0	7.0		
			C _L =50pF	—	3.7	7.9	1.0	9.0		
	t _{PHL}	3.3	C _L =15pF	—	3.3	8.8	1.0	10.5		
			C _L =50pF	—	4.6	12.4	1.0	14.0		
		5.0	C _L =15pF	—	2.5	5.9	1.0	7.0		
			C _L =50pF	—	3.5	7.9	1.0	9.0		
Input capacitance	C _{IN}	5.0	V _{IN} =V _{CC} or GND	—	4	10	—	10	pF	
Power dissipation capacitance	C _{PD}	—	No Load, f=1MHz	—	9.3	—	—	—	pF	

Timing Chart

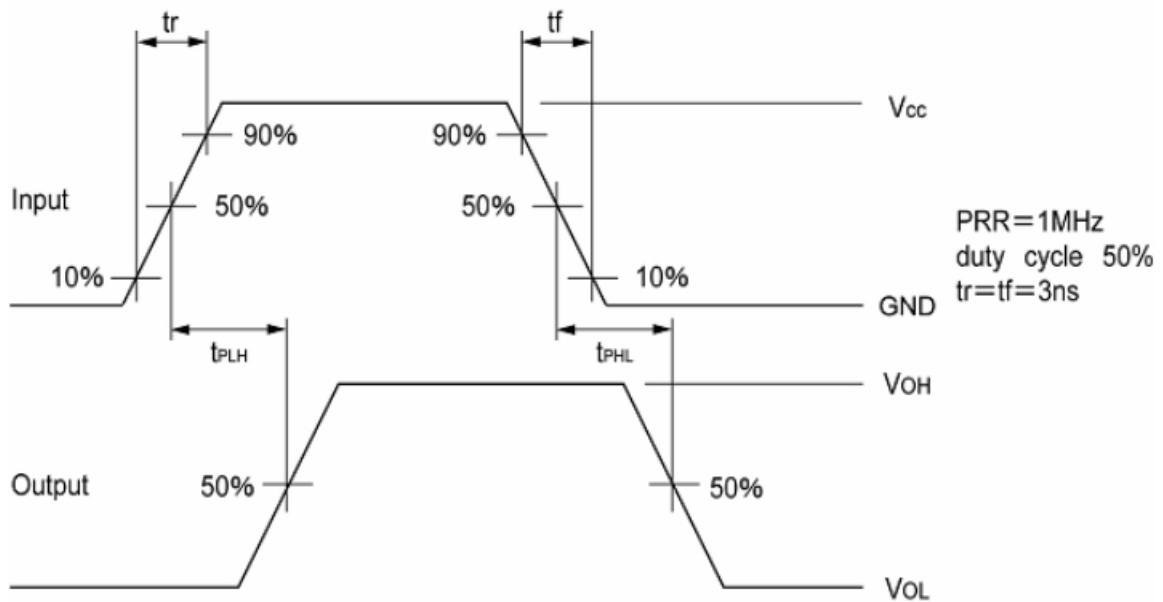

Test Circuit

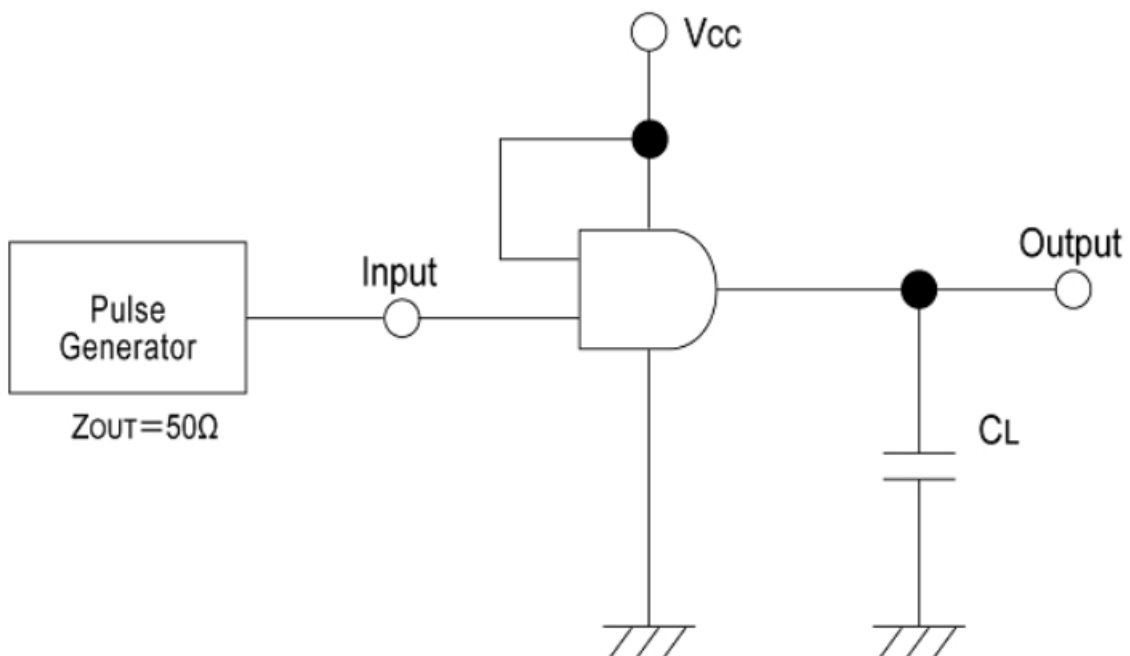

Note: Open output when measuring supply current

Package Information

◆SOT-353

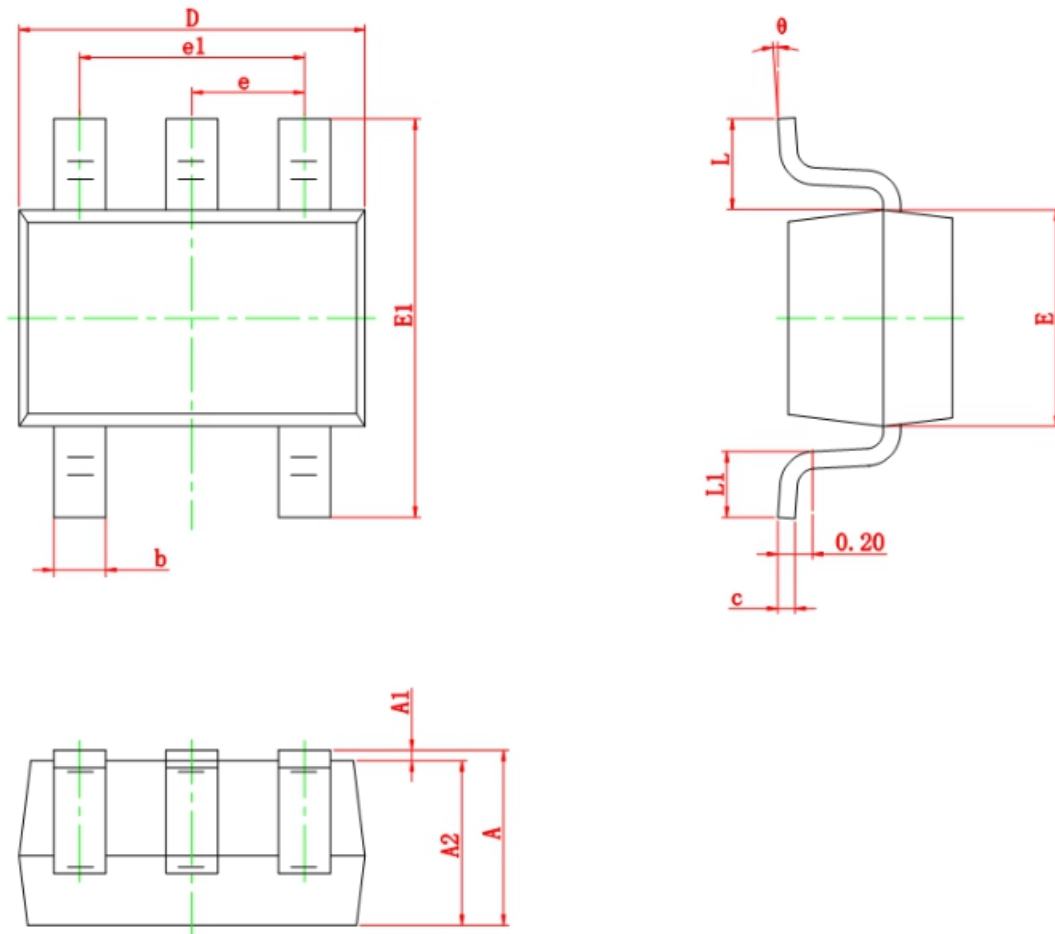

Symbol	Dimensions In Millimeters		Dimensions In Inches	
	Min	Max	Min	Max
A	0.900	1.100	0.035	0.043
A1	0.000	0.100	0.000	0.004
A2	0.900	1.000	0.035	0.039
b	0.150	0.350	0.006	0.014
c	0.080	0.150	0.003	0.006
D	2.000	2.200	0.079	0.087
E	1.150	1.350	0.045	0.053
E1	2.150	2.450	0.085	0.096
e	0.650 TYP		0.026 TYP	
e1	1.200	1.400	0.047	0.055
L	0.525 REF		0.021 REF	
L1	0.260	0.460	0.010	0.018
θ	0°	8°	0°	8°