

General Description

ECL2401 series is a group of high efficiency synchronous-rectification type buck regulator using a constant frequency, current mode architecture. Automatic PWM/PFM mode operation increases efficiency and decreases output voltage ripple at light loads, further extending battery life. Switching frequency is internally set at 1.4MHz, allowing the use of small surface mount inductors and capacitors. 100% duty cycle provides low dropout operation.

Features

- ◆ Output Current : 800mA
- ◆ Shutdown Current : <math><1\mu\text{A}</math>
- ◆ Oscillation Frequency : 1.4MHz

Applications

- ◆ LED driver

Typical Application Circuit

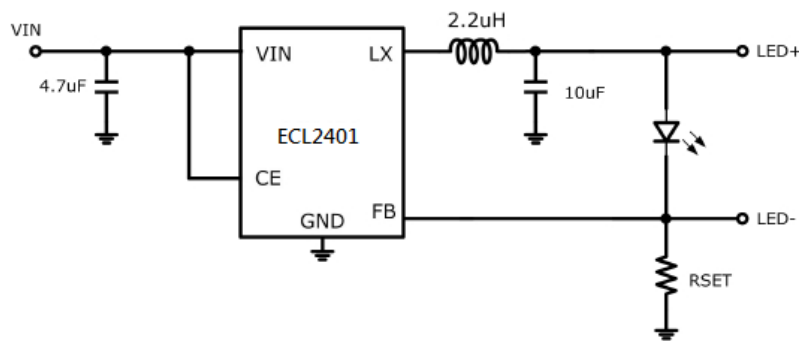

Note: $I_{LED} = 100\text{mV}/R_{SET}$

Functional Pin Description

Pin Number	Pin Name	Function
1	CE	Chip Enable Pin
2	GND	Common Ground
3	LX	Switching Output
4	VIN	Power Input
5	FB	Feedback Voltage Pin

Ordering Information

ECL2401 N XX N

Embossed Tape :

R : Standard Feed

S : Reverse Feed

Package Type :

B2 : SOT23-5L

A : $V_{FB} = 0.1\text{V}$

For example:

ECL2401AB2R is defined as ECL2401, the feedback voltage is 0.1V, the oscillator frequency of 1.4MHz, Package SOT23-5L, Reverse Feed.

Marking Information

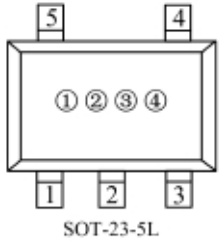
 <p style="text-align: center;">SOT-23-5L</p>	Designator		Symbol	Information
	product name	①	3	ECL2401
	feedback voltage	②	A	VFB=0.1V
	product package type	③	M	SOT23-5L
assembly lot No.	④			0-9 , A-Z; 0-9 , A-Z mirror writing , repeated (G , I , J , O , Q , W exception)

Pin Configuration

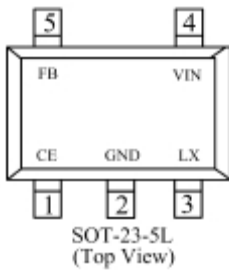

Function Block Diagram

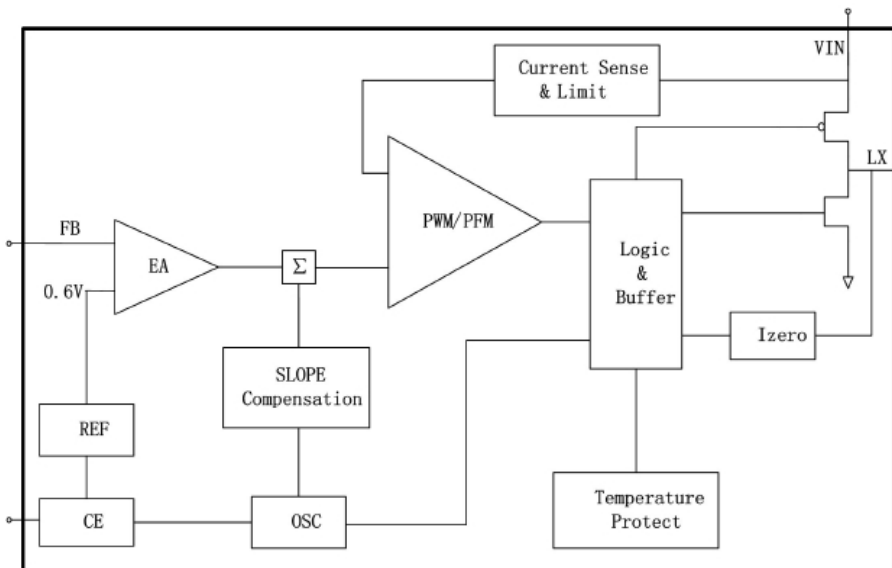



PWM/PFM Automatic Controlled DC-DC Converters — Backlight Driver

ECL2401

Absolute Maximum Ratings

Parameter		Symbol	Ratings	Units
Input Supply Voltage		VIN	-0.3~6.5	V
Output Voltage		VOUT	-0.3~6.5	
		VLX	-0.3~VIN + 0.3	
CE Voltage		VCE	-0.3~VIN + 0.3	V
Peak LX Current		ILX	1200	mA
Power Dissipation	SOT23-5L	Pd	250	mW
Operating Temperature Range		Topr	-40~ +85	°C
Storage Temperature Range		Tstg	-55~ +125	

Note: Absolute Maximum Ratings are those values beyond which the life of a device may be impaired.

Electrical Characteristics VIN=5V, L=2.2uH(Ta=25°C, unless otherwise noted)

Parameter	Symbol	Conditions	Min	Type	Max	Units
Feedback Voltage	VFB	-	0.09	0.1	0.11	V
Input Voltage Range	VIN	-	2	-	6	
Line regulation	ΔVOUT	I _{LED} =300mA	-	0.45	-	%
Efficiency	EFFI	I _{LED} =200mA	—	92	—	%
CE "Low" voltage	VCEL	-	-	-	0.9	V
CE "High" voltage	VCEH	-	1.1	-	-	V
Shutdown Current	ISHDN	VCE=0V	-	-	1	μA
Quiescent Current	IDD	VFB=0.1V*0.9	—	300	-	μA
Switch Current Limit	ILIM	-	-	1200	-	mA
PFM switching point	IPFM	VIN=5V		100		mA
Oscillation Frequency	FOSC	I _{LED} =500mA	-	1.4	-	MHz
Max Duty Circle	MAXDTY	-	100	-	-	%
Thermal Shutdown	TSD	-	-	150	-	°C
Thermal Hysteresis	THYST	-	-	20	-	°C

Typical Application

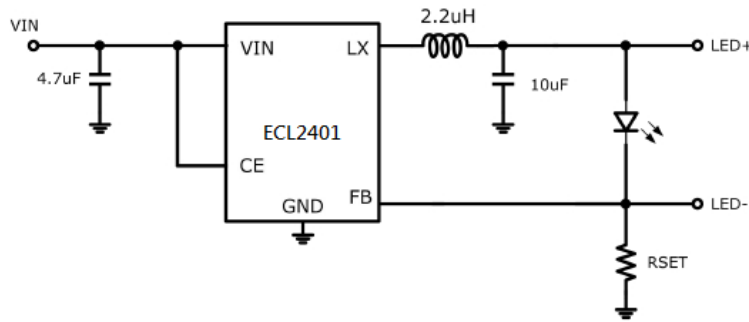

Figure 1 Typical application circuit

Note: $I_{LED} = 100\text{mV}/R_{SET}$

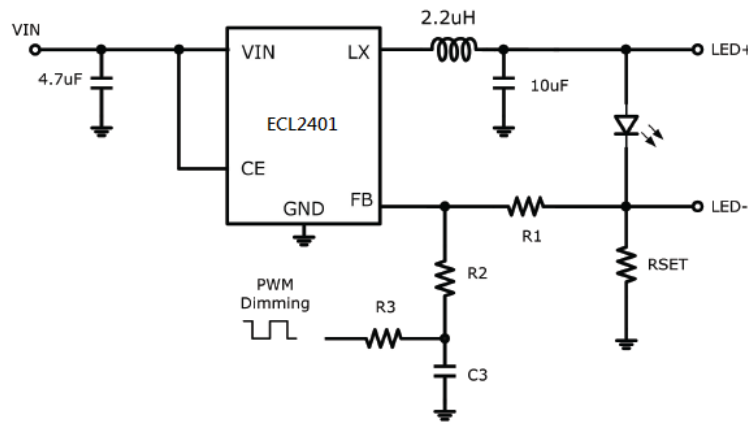

Figure 2 Typical application circuits with PWM dimming signal

Calculate I_{LED} using the following equations

$$I_{LED} = \frac{0.1 - \frac{R1 \times (VPWM \times DUTY - 0.1)}{(R2 + R3)}}{RSET}$$

Where $VPWM$ is the amplitude of PWM signal.

For example, for 3.3V $VPWM$, $R1=4.7K$, $R2=100K$, $R3=47K$.

The value of $C3$ depends on the frequency of PWM dimming; an empirical suggestion is around 0.1uF for MHz and 10uF for low frequency under KHz.

Typical Performance Characteristics

Efficiency VS Input Voltage

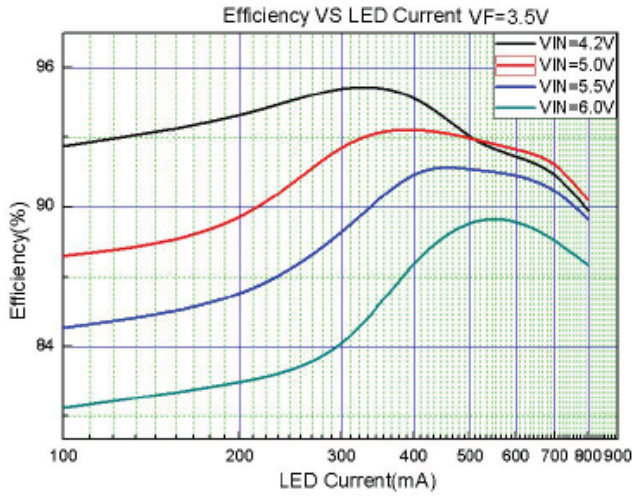

RON of power MOS VS VIN

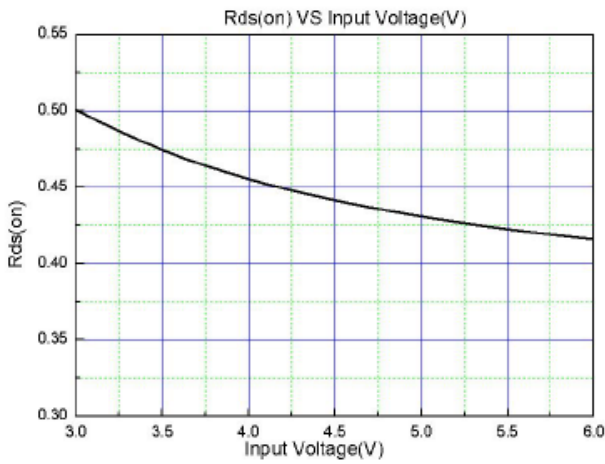

LED Current VS Input Voltage

VIN=5V, VF=3.5V

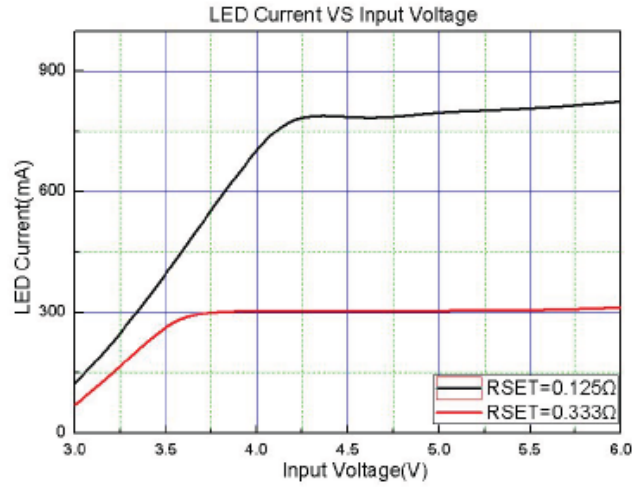

LED Current VS PWM Duty

VIN=5V, VF=3.5V

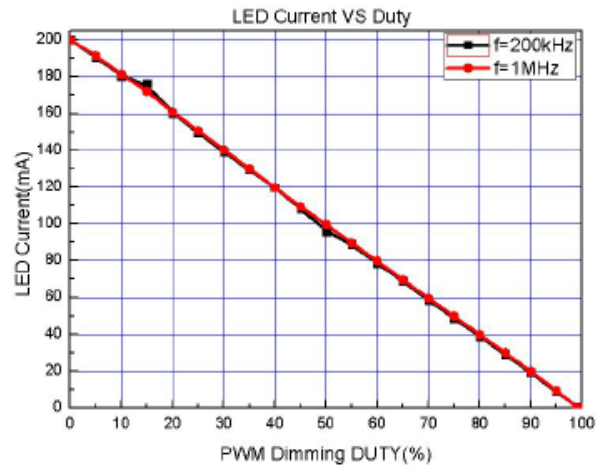

Voltage ripple of LED+, VIN=5V, ILED=200mA

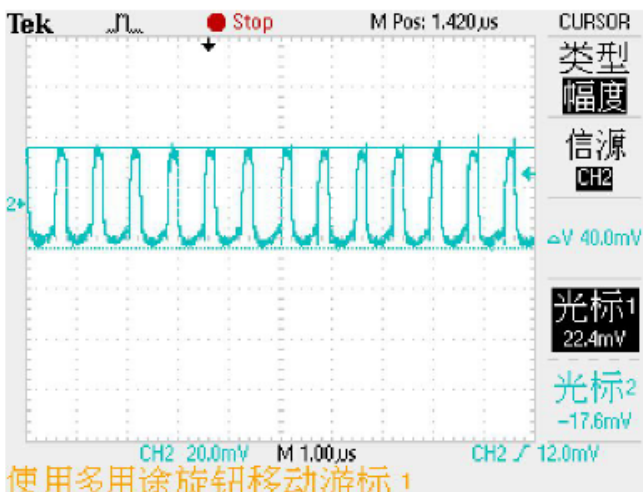

Quiescent Current VS Input Voltage

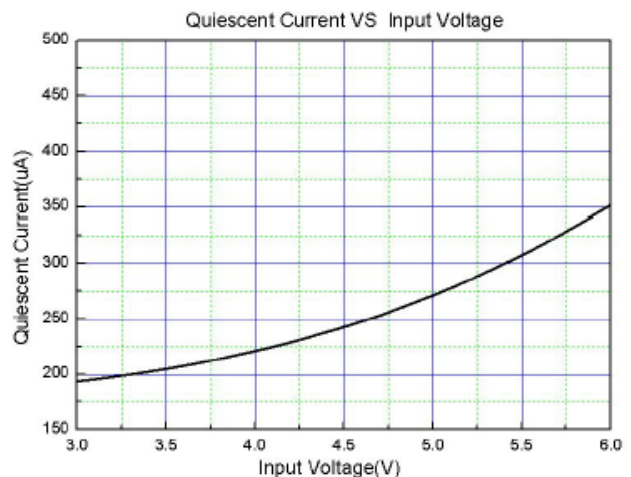

Package Information

SOT23-5L

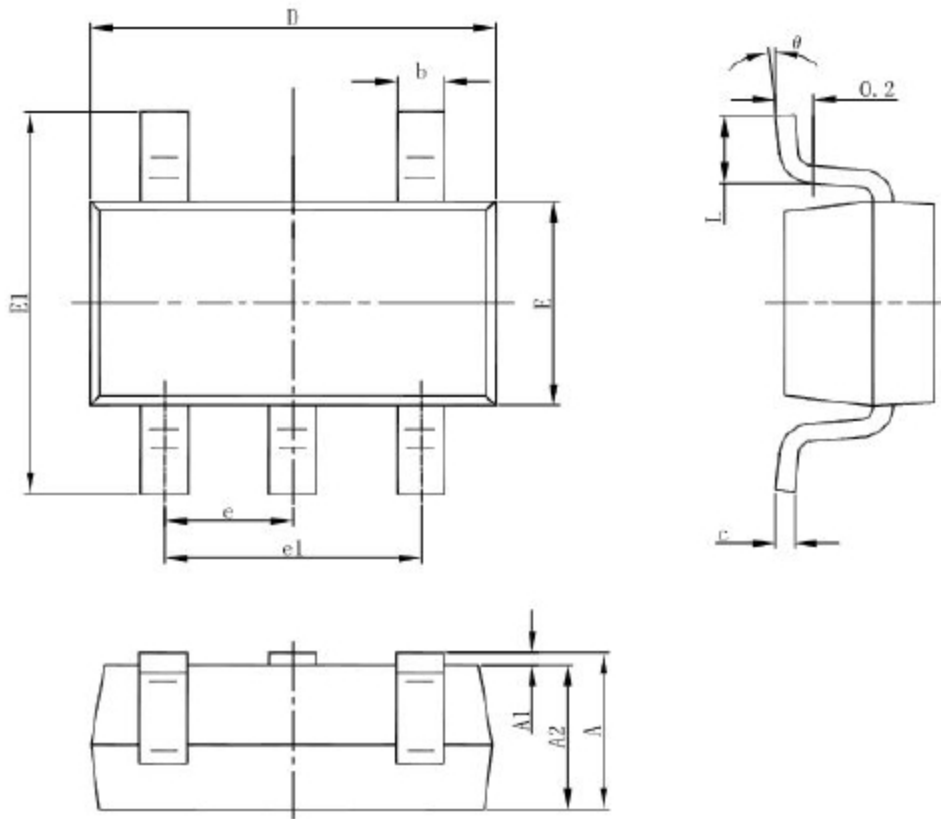

Symbol	Dimensions In Millimeters		Dimensions In Inches	
	Min	Max	Min	Max
A	1.050	1.250	0.041	0.049
A1	0.000	0.100	0.000	0.004
A2	1.050	1.150	0.041	0.045
b	0.300	0.500	0.012	0.020
c	0.100	0.200	0.004	0.008
D	2.820	3.020	0.111	0.119
E	1.500	1.700	0.059	0.067
E1	2.650	2.950	0.104	0.116
e	0.950(BSC)		0.037(BSC)	
e1	1.800	2.000	0.071	0.079
L	0.300	0.600	0.012	0.024
θ	0°	8°	0°	8°