



Description

The EC432 is a low voltage three terminal adjustable shunt regulator with a guaranteed thermal stability over applicable temperature ranges. The output voltage can be set to any value between VREF (approximately 1.24 V) to 12V with two external resistors. This device has a typical output impedance of 0.25Ω. Active output circuitry provides a very sharp turn on characteristic, making this device excellent replacement for Zener diodes in many applications. The EC432 is characterized for operation from 0oC to 105oC, and four package options (SOT23-3L, SOT23-5L, TO92-3L and SOP8) allow the designer the opportunity to select the proper package for their applications.

Features

- ◆ Low voltage operation (1.24V)
- ◆ Adjustable output voltage $V_0 = V_{REF}$ to 18V
- ◆ Wide operating current range 60μA to 100mA
- ◆ Low dynamic output impedance 0.05Ω (Typ.)
- ◆ Trimmed bandgap design up to + 0.5%.
- ◆ ESD rating is 4KV(Per MIL-STD-883D)
- ◆ Available in Halogen-Free Packages.

Applications

- ◆ Linear Regulators
- ◆ Adjustable Supplies
- ◆ Switching Power Supplies
- ◆ Battery Operated Computers
- ◆ Instrumentation
- ◆ Computer Disk Drives

Ordering/Marking Information

EC432NN XX X

R : Tape & Reel

Package Type :

- B1 : SOT23-3L(2.8*1.5)
- BF : SOT23-3B(2.8*1.2)
- B2 : SOT23-5
- A6 : TO92-3L
- M1 : SOP8

Package	Marking	Production Year Code	Production Week Code	Lead-Free Package
SOT23-3L	SE432W	Starting with S, a bar on top of S is for production year 2001, and underlined S is for year 2002. The next character is marked on top for 2003, and underlined for 2004. The naming pattern continues with consecutive characters for later years.	A-Z: 1-26 a-z: 27-52	Lead-free package is indicated by a dot on top of the week code.
SOT23-5L	SE432W			
SOP8	SE432 YYWW	YY is for the year of production. 04 means the product is manufactured in year of 2004.	WW is for the week of production. 26 means the product is manufactured in the 26 th week	Lead-free package is indicated by LF after YYWW.
TO92-3L	SE432 YYWW			

Pin Configuration

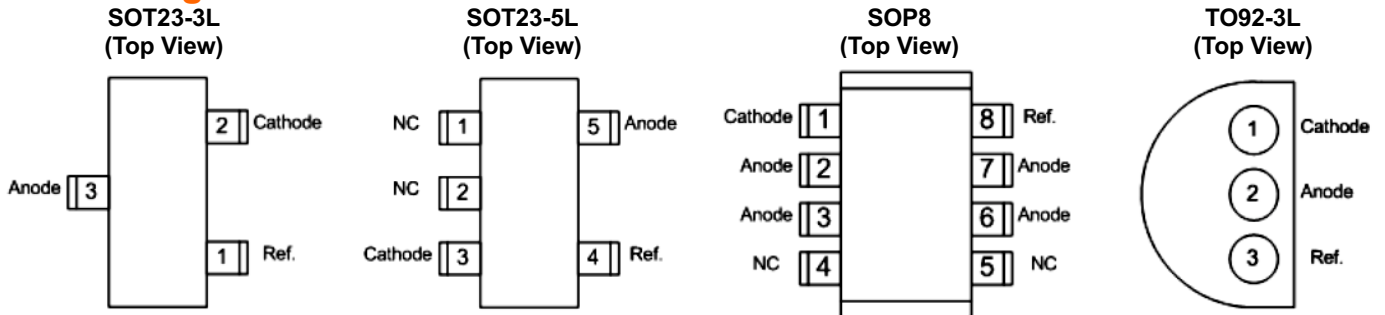

Absolute Maximum Ratings

Parameter	Symbol	Maximum	Units
Cathode Voltage	V_{KA}	20	V
Continuous Cathode Current	I_{KA}	150	mA
Reference Current	I_{REF}	10	mA
Operating Junction Temperature Range	T_J	150	°C
Storage Temperature Range	T_{STG}	-40 to 150	°C
Thermal Resistance	θ_{JA}	230 (SOT23-3L)	°C/W
		230 (SOT23-5L)	
		150 (SOP8)	
		220 (TO92-3L)	
Lead Temperature (Soldering) 10 seconds	T_{LEAD}	260	°C



Electrical Characteristics

Parameter		Symbol	Test Conditions & Circuit	Min	Typ	Max	Unit
Reference Voltage	1.240V ± 0.5%	V _{REF}	Test circuit #1 V _{KA} = V _{REF} , I _{KA} = 10mA	1234	1240	1246	mV
	1.240V ± 1.0%			1228	1240	1252	
	1.240V ± 1.5%			1221	1240	1259	
	1.240V ± 2.0%			1215	1240	1265	
Deviation of Reference Voltage over Full Temperature Range		V _{I(DEV)}	Test circuit #1 V _{KA} = V _{REF} , I _{KA} = 10mA, T _A = 0°C - 105°C	--	4	15	mV
Ratio of Change in Reference Voltage to the Change in Cathode Voltage		ΔV _{REF} /ΔV _{KA}	Test circuit #2 I _{KA} = 10mA, ΔV _{KA} = 12V to V _{REF}	--	-1.0	-2.7	mV/V
Reference Current		I _{REF}	Test circuit #2 I _{KA} = 10mA, R1=10kΩ, R2 = ∞	--	0.25	-	μA
Deviation of Reference Current over Full Temperature Range		I _{I(DEV)}	Test circuit #2 I _{KA} = 10mA, R1=10kΩ, R2 = ∞ T _A = 0°C - 105°C	--	0.10	0.50	μA
Minimum Cathode Current for Regulation		I _{MIN}	Test circuit #1 V _{KA} = V _{REF}	--	60	100	μA
Off-state Cathode Current		I _{OFF}	Test circuit #3 V _{KA} = 12V, V _{REF} = 0	--	0.04	0.8	μA
Dynamic Impedance		Z _{KA}	Test circuit #1 I _{KA} = 100μA - 80mA, V _{KA} = V _{REF} , f ≤ 1kHz	--	0.05	0.15	Ω

Note 1: Upon Customer Request.

Typical Performance Characteristics

Cathode Current VS Cathode Voltage

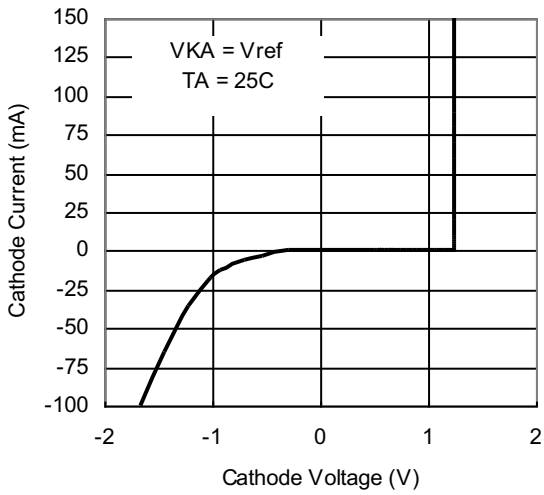

Cathode Current VS Cathode Voltage

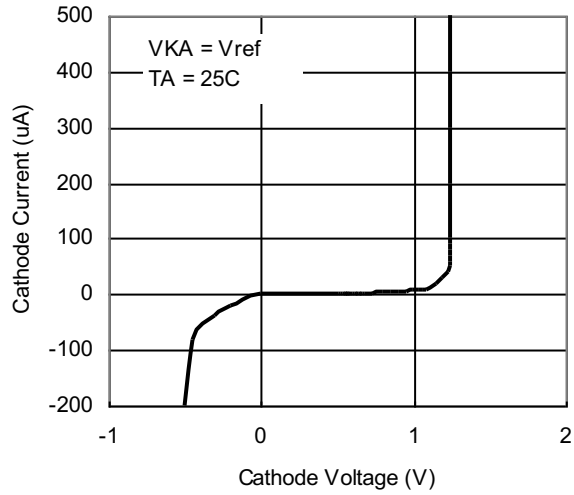

Reference Voltage VS Junction Temperature

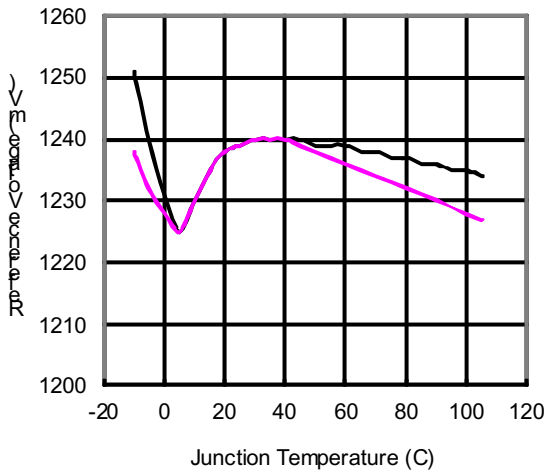

Reference Input Current VS Junction Temperature

Junction Temperature (C)

Stability Boundary Condition

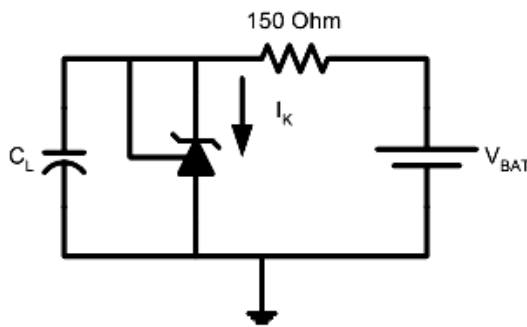
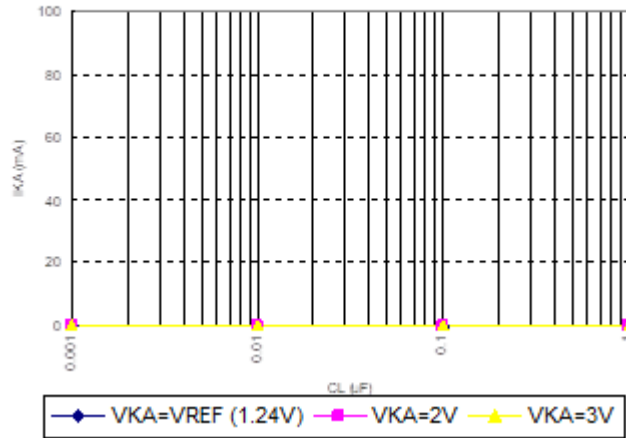

Test Circuit for $V_{KA} = V_{REF}$

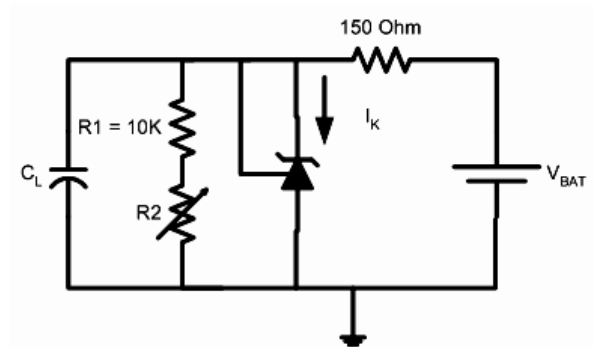

Test Circuit for $V_{KA} = 2V, 3V$

The areas under the curves represent conditions that may cause the device to oscillate. For $V_{KA} = 2V$ and $3V$ curves, R_2 and V_{BAT} were adjusted to establish the initial V_{KA} and I_K conditions with $C_L = 0$. V_{BAT} and C_L then were adjusted to determine the ranges of stability. As the graph suggested, SE432 is unconditional stable with I_K from 0 to 100mA and with C_L from 0.001uF to 1uF.

Symbol Diagram

Block Diagram

Test Circuits

Test Circuit 1: $V_{KA} = V_{REF}$	Test Circuit 2: $V_{KA} > V_{REF}$	Test Circuit 3: Off State Current
--	--	--

Application Circuit

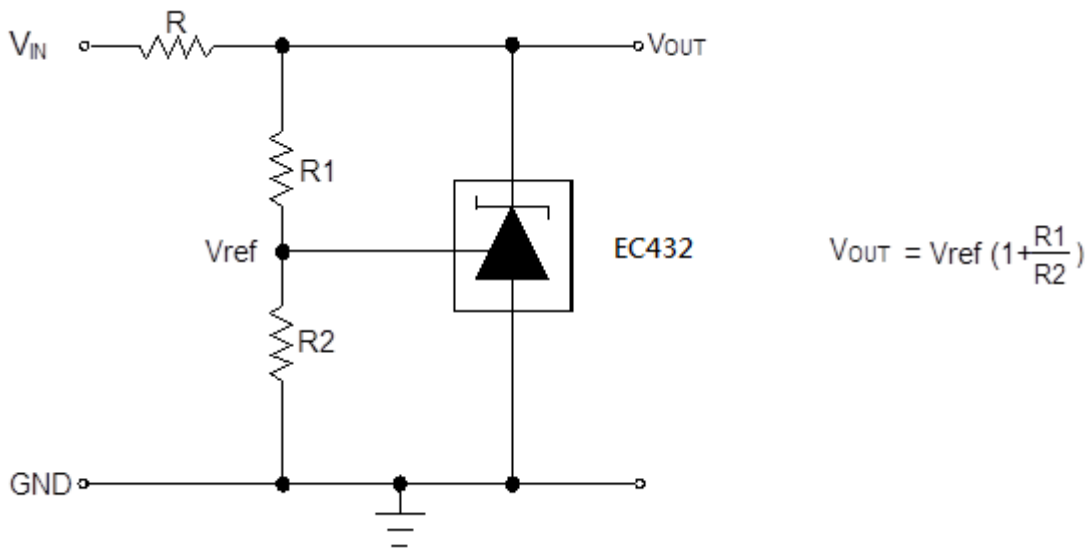

Package Outline Dimensions

SOT23-3B

DIMENSIONS				
DIM ^N	INCHES		MM	
	MIN	MAX	MIN	MAX
A	0.110	0.120	2.80	3.04
B	0.047	0.055	1.20	1.40
C	0.083	0.104	2.10	2.64
D	0.035	0.040	0.89	1.03
E	0.070	0.080	1.78	2.05
F	0.018	0.024	0.45	0.60
G	0.015	0.020	0.37	0.51
H	0.0005	0.004	0.013	0.10
J	0.034	0.040	0.887	1.02
K	0.003	0.007	0.085	0.18
L	-	0.027	-	0.69

SOT23-3L

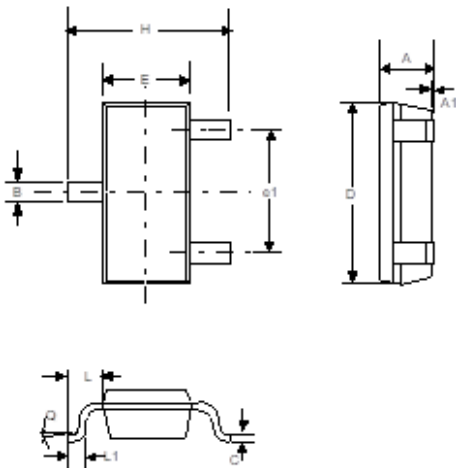

DIMENSIONS				
DIM ^N	INCHES		MM	
	MIN	MAX	MIN	MAX
A	0.035	0.043	0.90	1.10
A1	0.0004	0.005	0.01	0.13
B	0.012	0.020	0.30	0.50
C	0.004	0.008	0.09	0.20
D	0.110	0.122	2.80	3.10
H	0.098	0.122	2.50	3.10
E	0.059	0.067	1.50	1.70
e	0.037REF		0.95REF	
e1	0.075REF		1.90REF	
L1	0.008	0.022	0.20	0.55
L	0.014	0.031	0.35	0.80
Q	0°C	10°C	0°C	10°C

SOT23-5L

DIMENSIONS				
DIM ^N	INCHES		MM	
	MIN	MAX	MIN	MAX
A	0.110	0.120	2.80	3.05
B	0.059	0.070	1.50	1.75
C	0.036	0.051	0.90	1.30
D	0.014	0.020	0.35	0.50
E	-	0.037	-	0.95
F	-	0.075	-	1.90
H	-	0.006	-	0.15
J	0.0035	0.008	0.090	0.20
K	0.102	0.118	2.60	3.00



SOP8

DIMENSIONS				
DIM ^N	INCHES		MM	
	MIN	MAX	MIN	MAX
A	0.0532	0.0688	1.35	1.75
A1	0.0040	0.0098	0.10	0.25
B	0.0130	0.0200	0.33	0.51
B1	0.050 BSC		1.27 BSC	
C	0.0075	0.0098	0.19	0.25
D	0.1890	0.1968	4.80	5.00
H	0.2284	0.2440	5.80	6.20
E	0.1497	0.1574	3.80	4.00

TO92-3L

DIMENSIONS				
DIM ^N	INCHES		MM	
	MIN	MAX	MIN	MAX
A	0.175	0.205	4.445	5.207
B	0.170	0.210	4.318	5.334
E	0.500	0.610	12.70	15.50
F	0.016	0.021	0.407	0.533
G	0.045	0.055	1.143	1.397
H	0.095	0.105	2.413	2.667
J	0.080	0.105	2.032	2.667
K	0.125	0.165	3.175	4.191