

1A Low Dropout Positive Voltage Regulator

GENERAL DESCRIPTION

The EC50117C Series are available in fixed and adjustable output voltage versions. Over current and thermal overload protection are integrated onto the chip. Output current will decrease while it reaches the preset current or temperature limit. The dropout voltage is specified at 1.2V Maximum at full rated output current. EC50117C Series provide excellent regulation over variations due to changes in line, load and temperature. EC50117C Series are three terminal regulators and available in popular packages.

FEATURES

- Low Dropout Voltage 1.2V at 1A
- Adjustable or Fixed Voltage (1.8V, 2.5V, 3.3V, 5V)
- Over Current Protection
- Thermal Overload Protection
- Maximum Line Regulation 0.45%
- Maximum Load Regulation 0.4%
- Adjust Pin Current Less Than 90 μ A

Applications

- SCSI-2 Active Termination
- High Efficiency Linear Regulators
- 5V to 3.3V Voltage Converter
- Battery Charger
- Battery Management Circuits For Notebook And Palmtop PCs
- Core Voltage Supply: FPGA, PLD, DSP, CPU

PIN ASSIGNMENT

Package: SOT89-3L

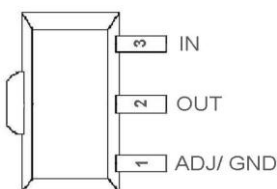

Package: SOT89-3L (Pin type A)

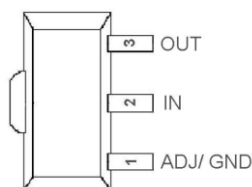

Package: TO252-3L

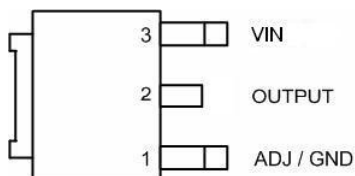

Package: TO-263-2L

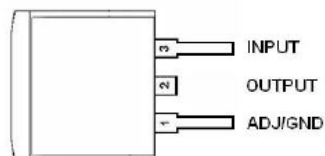

Package: SOT223-3L

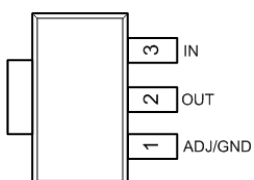



1A Low Dropout Positive Voltage Regulator

Ordering Information

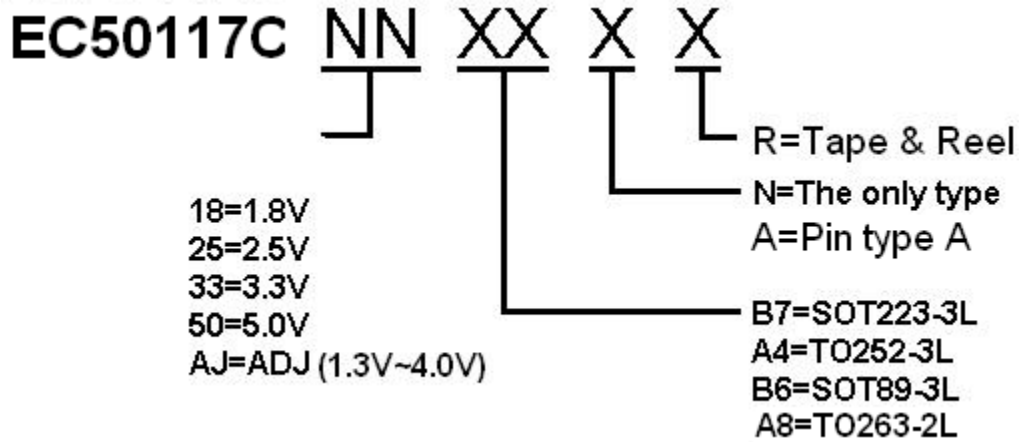

Part Number	Package	Marking	Marking Information
EC50117CXXA4NR	TO252-3L	50117K-G	
EC50117CXXB6NR	SOT89-3L	50117K-G	
EC50117CXXB6AR		50117K-G	
EC50117CXXB7NR	SOT223-3L	50117K-G	
EC50117CXXA8NR	TO263-2L	50117K-G	

ABSOLUTE MAXIMUM RATINGS

Characteristics		Symbol	Maximum	Unit
DC Supply Voltage		V_{IN}	20V	V
Operating Junction Temperature Range		T_{OPR}	0 to +125	°C
Storage Temperature Range		T_{STG}	-65 to 150	°C
Lead Temperature (Soldering) 5 Sec		T_{LEAD}	260	°C
Electrostatic Discharge Sensitivity			2	KV/Min
Thermal Resistance Junction to Ambient	SOT89-3L	θ_{JA}	175	°C/W
	SOT223-3L		135	
	TO252-3L		100	
	TO263-2L		60	
Thermal Resistance Junction to Case	SOT89-3L	θ_{JC}	58	°C/W
	SOT223-3L		15	
	TO252-3L		12	
	TO263-2L		4	
Internal Power Dissipation	SOT89-3L	P_D	0.57	W
	SOT223-3L		0.74	
	TO252-3L		1	
	TO263-2L		1.67	



1A Low Dropout Positive Voltage Regulator

ELECTRICAL CHARACTERISTICS

(C_i=10uF, C_o=100uF, unless otherwise noted.)

Parameter	Test Conditions		Min	Typ	Max	Units	
Output Voltage	EC50117C-1.8V	I _o = 0mA, V _{IN} =3.3V	1.764	1.800	1.836	V	
	EC50117C-2.5V	I _o = 0mA, V _{IN} =4V	2.450	2.500	2.550	V	
	EC50117C-3.3V	I _o = 0mA, V _{IN} =4.8V	3.234	3.300	3.366	V	
	EC50117C-5.0V	I _o = 0mA, V _{IN} =6.5V	4.900	5.000	5.10	V	
Reference Voltage	EC50117C-ADJ	I _o =10mA, V _{IN} -V _o =3V	1.232	1.25	1.268		
Line Regulation	EC50117C-1.8V	I _o = 0mA, V _{IN} =3.3~10V	---	1	6	mV	
	EC50117C-2.5V	I _o = 0mA, V _{IN} =4~10V	---	1	7	mV	
	EC50117C-3.3V	I _o = 0mA, V _{IN} =4.8~10V	---	2	7	mV	
	EC50117C-5.0V	I _o = 0mA, V _{IN} =6.5~10V	---	3	10	mV	
	EC50117C-ADJ	I _o = 10mA, V _{IN} -V _o =1.5~10V	---	0.1	0.4	%	
Load Regulation	EC50117C-1.8V	I _o =0~800mA, V _{IN} =3.3V, T _J =25°C	---	---	0.4	%	
		I _o =0~1000mA, V _{IN} =3.3V, ^{NOTE1}	---	---	1		
	EC50117C-2.5V	I _o =0~800mA, V _{IN} =4V, T _J =25°C	---	---	0.4	%	
		I _o =0~1000mA, V _{IN} =4V, ^{NOTE1}	---	---	1		
	EC50117C-3.3V	I _o =0~800mA, V _{IN} =4.8V, T _J =25°C	---	---	0.4	%	
		I _o =0~1000mA, V _{IN} =4.8V, ^{NOTE1}	---	---	1		
	EC50117C-5.0V	I _o =0~800mA, V _{IN} =6.5V, T _J =25°C	---	---	0.4	%	
		I _o =0~1000mA, V _{IN} =6.5V, ^{NOTE1}	---	---	1		
	EC50117C-ADJ	I _o =0~800mA, V _{IN} =2.75V, T _J =25°C	---	---	0.4	%	
		I _o =0~1000mA, V _{IN} =2.75V, ^{NOTE1}	---	---	1		
	Dropout Voltage (^{NOTE3})	EC50117C-ADJ /1.8/2.5/3.3/5.0	I _o =100mA, T _J =25°C	---	1.05	1.15	V
			I _o =500mA, T _J =25°C	---	1.1	1.15	
I _o =1000mA, T _J =25°C			---	1.2	1.3		
I _o =1000mA,			---	1.2	1.55		
Current Limit	EC50117C-ADJ /1.8/2.5/3.3/5.0	V _{IN} -V _o = 1.5V	2000	2600	3200	mA	
Minimum Load Current	EC50117C-ADJ (^{NOTE1} & ^{NOTE2})	V _{IN} -V _o = 13.75V ^{NOTE1} & ^{NOTE2}	---	1.7	5	mA	
Quiescent Current	EC50117C-1.8/2.5/ 3.3/5.0(^{NOTE1})	V _{IN} -V _o = 5V ^{NOTE1}	---	6	10	mA	
Adjust pin current (^{NOTE1} & ^{NOTE2})	---	I _o =10mA, V _{IN} -V _o = 1.5V ^{NOTE1} & ^{NOTE2}	---	50	120	μA	
Adjust pin current change	---	I _o =10mA, V _{IN} -V _o = 1.4~10V	---	0.5	5	uA	
Ripple Rejection	EC50117C-ADJ /1.8/2.5/3.3/5.0	f=120Hz, V _{IN} -V _o =3V+1.5Vpp, Co=22uF	---	62	---	dB	
Temperature Drift	EC50117C-1.8/2.5 /3.3/5.0	T _J =0~25°C	---	0.5	---	%	
	EC50117C-ADJ	T _J =0~25°C	---	2	---	%	

Note: 1. Specification applies over the full operating junction temperature range, 0~125°C

2. EC50117C-ADJ require a minimum load current for ±3% regulation

3. Dropout voltage is the input voltage minus output voltage that produces a 1% decrease in output voltage.

1A Low Dropout Positive Voltage Regulator

Characteristics Curve

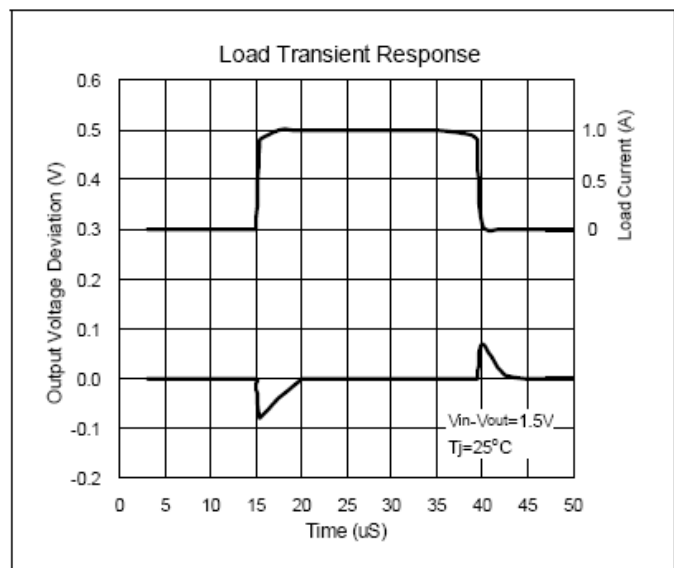
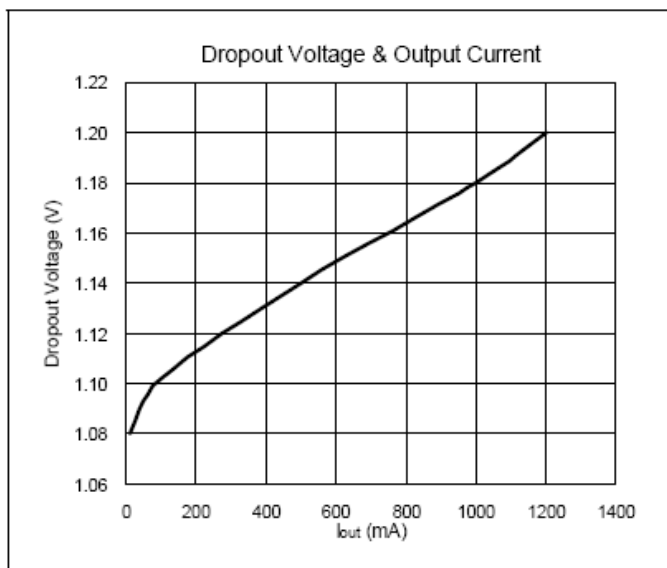
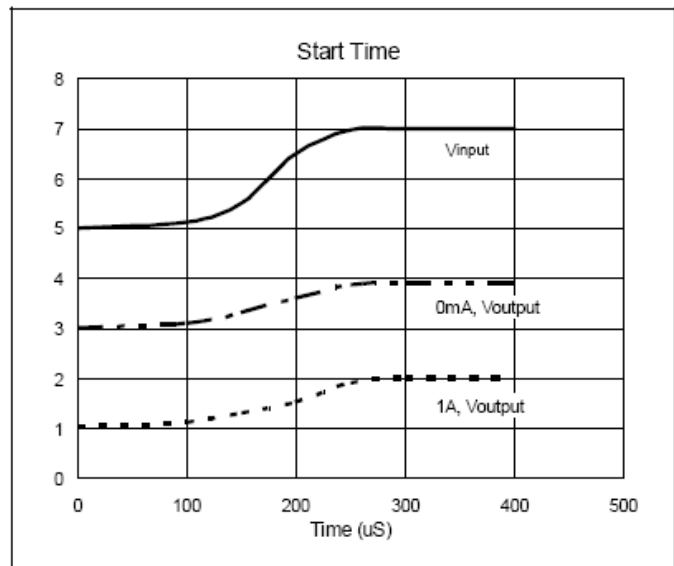
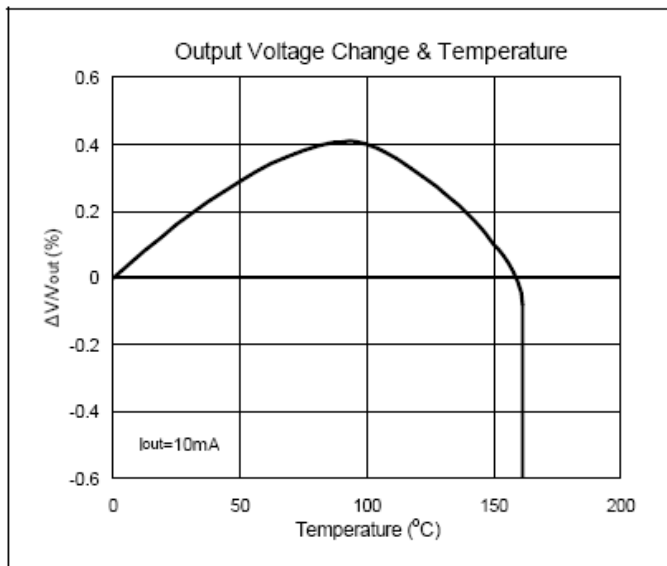
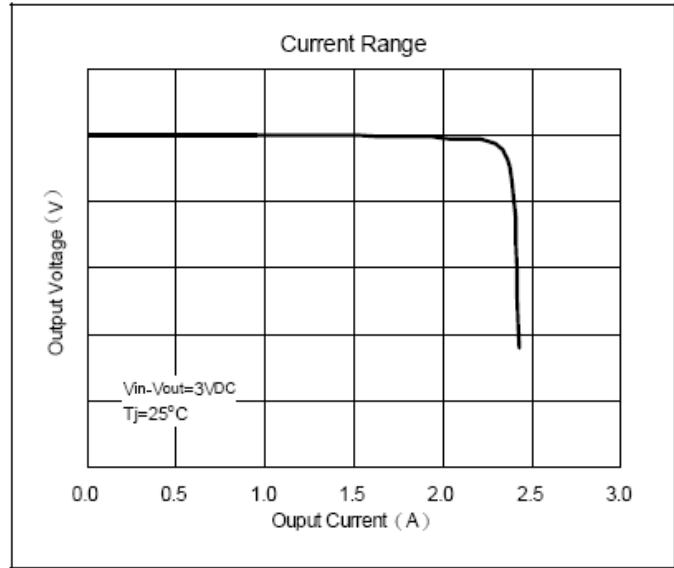
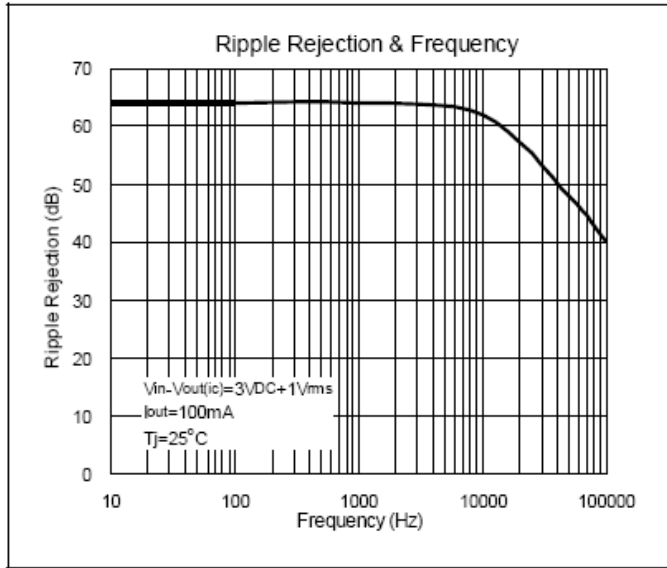

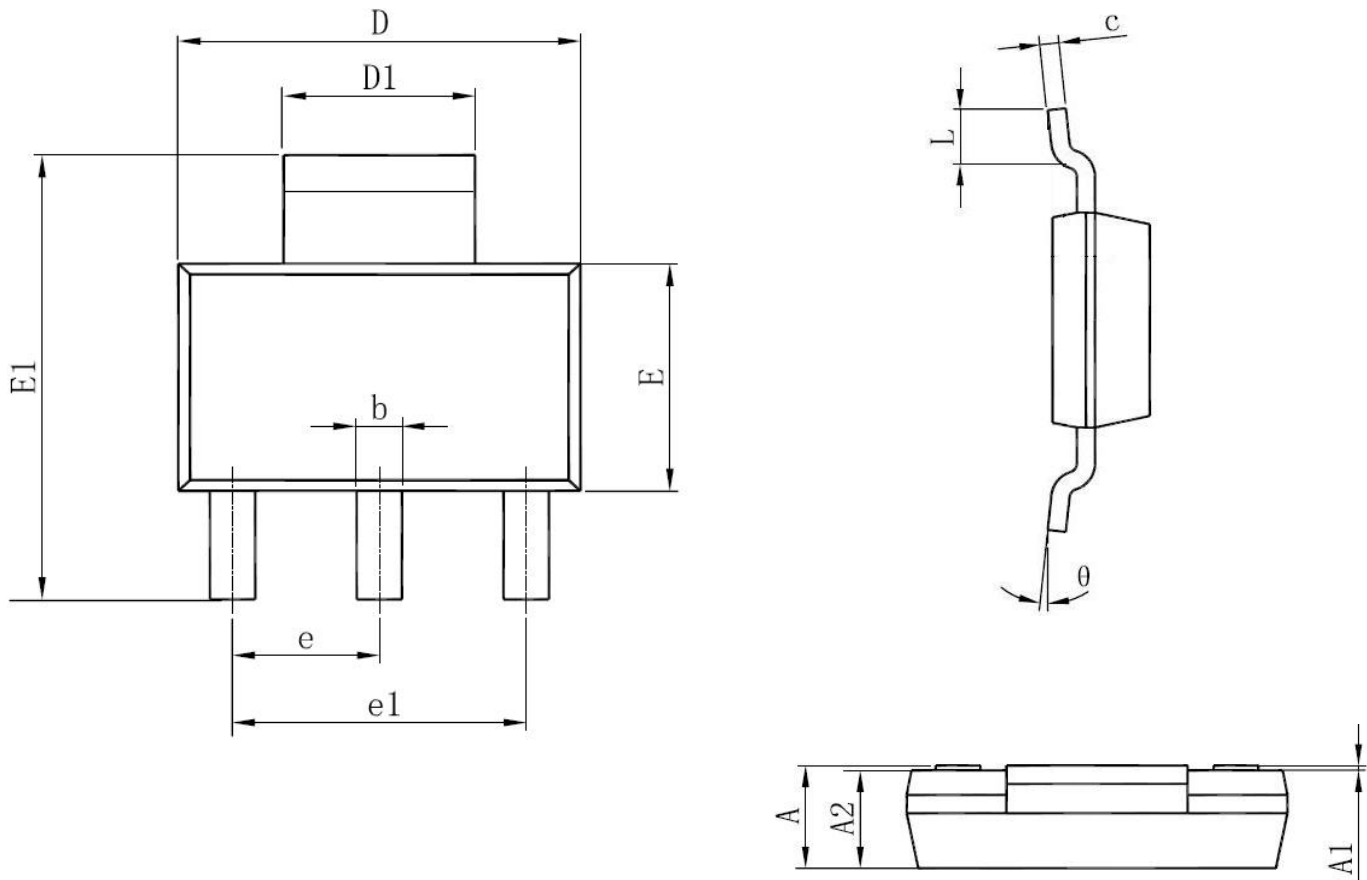
1A Low Dropout Positive Voltage Regulator
Mechanical Dimensions
OUTLINE DRAWING SOT223-3L

Symbol	Dimensions In Millimeters		Dimensions In Inches	
	Min	Max	Min	Max
A	1.450	1.800	0.0571	0.071
A1	0.020	0.100	0.0008	0.004
A2	1.430	1.750	0.056	0.069
b	0.610	0.820	0.024	0.032
c	0.230	0.350	0.009	0.014
D	6.300	6.710	0.248	0.264
D1	2.900	3.150	0.114	0.124
E	3.300	3.710	0.130	0.148
E1	6.710	7.290	0.264	0.287
e	2.150	2.450	0.085	0.097
e1	4.450	4.750	0.175	0.187
L	0.900	1.150	0.035	0.045
θ	0°	10°	0°	10°

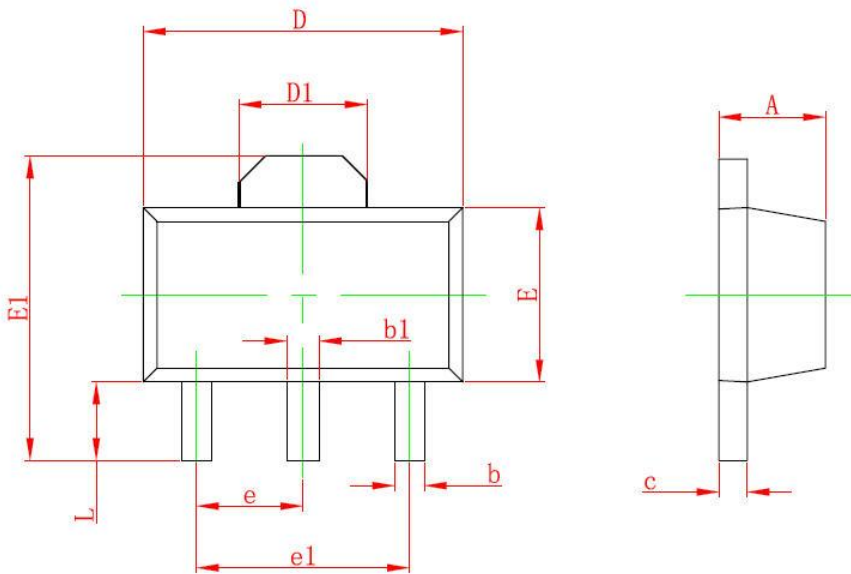
1A Low Dropout Positive Voltage Regulator
Mechanical Dimensions (Continued)
OUTLINE DRAWING SOT89-3L

Symbol	Dimensions In Millimeters		Dimensions In Inches	
	Min	Max	Min	Max
A	1.400	1.600	0.055	0.063
b	0.320	0.520	0.013	0.197
b1	0.400	0.580	0.016	0.023
c	0.350	0.440	0.014	0.017
D	4.400	4.600	0.173	0.181
D1	1.445	1.775	0.057	0.069
E	2.300	2.600	0.091	0.102
E1	3.940	4.250	0.155	0.167
e	1.350	1.650	0.053	0.065
e1	2.850	3.150	0.112	0.124
L	0.900	1.200	0.035	0.047

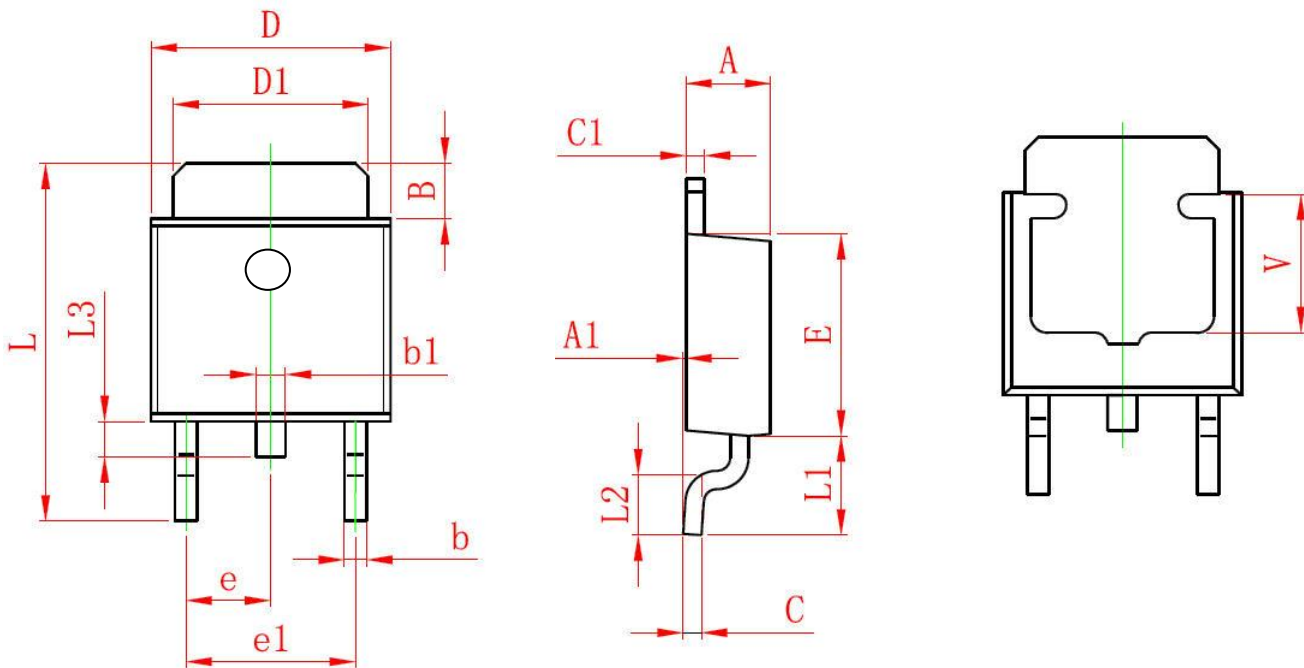
1A Low Dropout Positive Voltage Regulator
Mechanical Dimensions (Continued)
OUTLINE DRAWING TO252-3L

Symbol	Dimensions In Millimeters		Dimensions In Inches	
	Min.	Max.	Min.	Max.
A	2.200	2.400	0.087	0.094
A1	0.000	0.127	0.000	0.005
B	1.350	1.650	0.053	0.065
b	0.450	0.750	0.018	0.030
b1	0.600	1.000	0.024	0.040
c	0.430	0.580	0.017	0.023
c1	0.430	0.580	0.017	0.023
D	6.300	6.700	0.249	0.264
D1	5.100	5.500	0.201	0.217
E	5.400	5.700	0.213	0.224
e	2.150	2.450	0.085	0.097
e1	4.450	4.750	0.175	0.187
L	9.500	9.900	0.374	0.390
L1	2.550	2.900	0.100	0.114
L2	1.400	1.780	0.055	0.070
L3	0.600	1.000	0.024	0.040
V	3.400	3.800	0.134	0.150

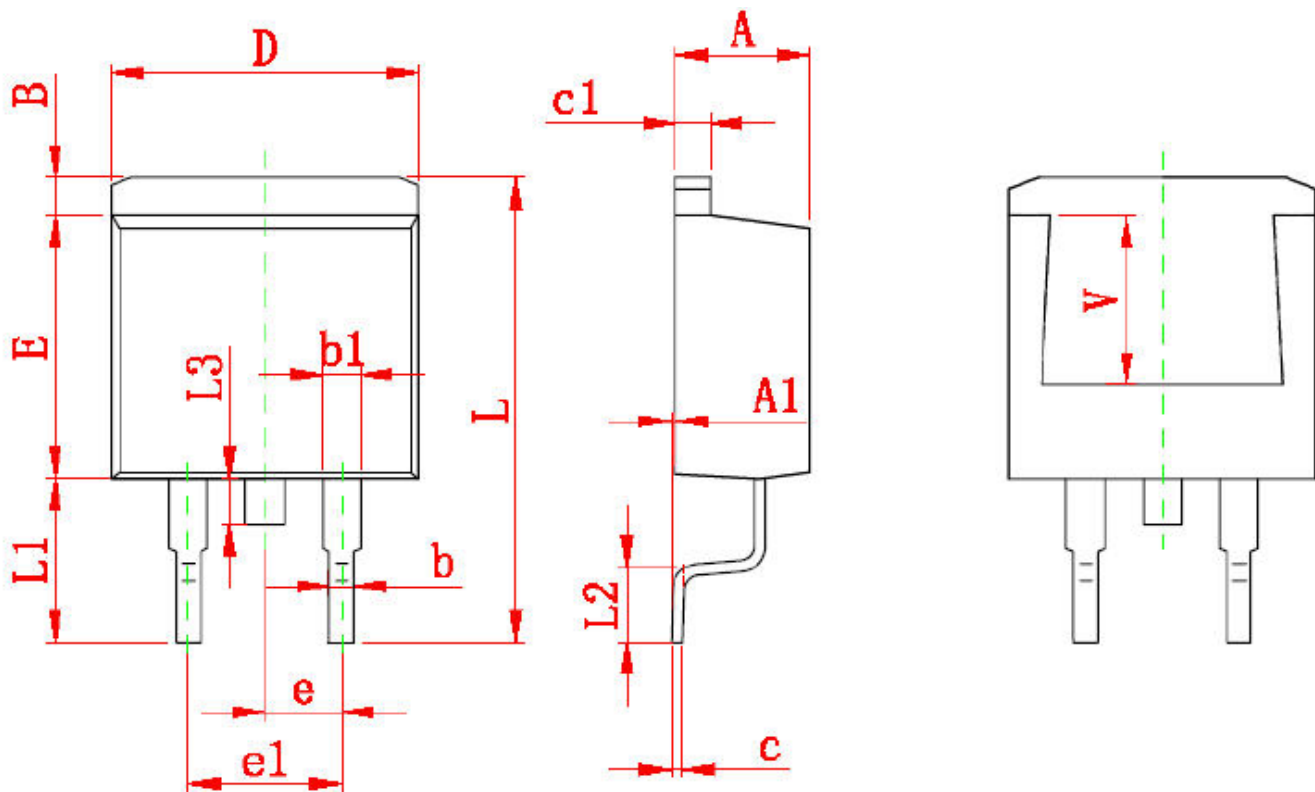
1A Low Dropout Positive Voltage Regulator
Mechanical Dimensions (Continued)
OUTLINE DRAWING TO263-2L

Symbol	Dimensions In Millimeters		Dimensions In Inches	
	Min	Max	Min	Max
A	4.470	4.670	0.176	0.184
A1	0.000	0.150	0.000	0.006
B	1.170	1.370	0.046	0.054
b	0.710	0.910	0.028	0.036
b1	1.170	1.370	0.046	0.054
c	0.310	0.530	0.012	0.021
c1	1.170	1.370	0.046	0.054
D	10.010	10.310	0.394	0.406
E	8.500	8.900	0.335	0.350
e	2.540 TYP		0.100 TYP	
e1	4.980	5.180	0.196	0.204
L	15.050	15.450	0.593	0.608
L1	5.080	5.480	0.200	0.216
L2	2.340	2.740	0.092	0.108
L3	1.300	1.700	0.051	0.067
V	5.600 REF		0.220 REF	