

General Description

The EC9303 is a monolithic synchronous buck regulator. The device integrates internal high side and external low side power MOSFETs, and provides 5A of continuous load current over a wide input voltage of 8V to 38V. Current mode control provides fast transient response and cycle-by-cycle current limit.

An internal soft-start prevents inrush current at turn-on, This device available in SOP8L-EP (Exposed pad) package, provides a very compact solution with minimal external components.

Features

- Wide 8V to 38V Operating Input Range
- Integrated 80mΩ Power MOSFET Switches
- Output Adjustable from VFB(1.0V) to 20V
- Up to 95% Efficiency
- Internal Soft-Start.
- Stable with Low ESR Ceramic Output Capacitors
- Fixed 160KHz Frequency
- Cycle-by-Cycle Over Current Protection
- Input Under/Over Voltage Lockout

Application Circuit

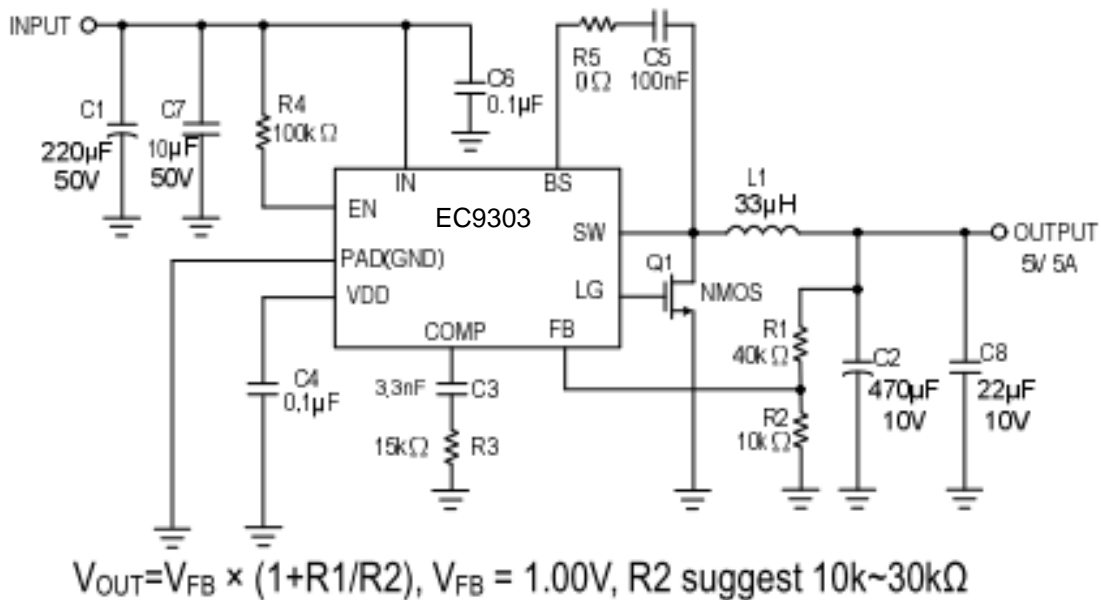

Pin Assignment

The package of EC9303 is SOP8L-EP(Exposed pad); the pin assignment is given by:

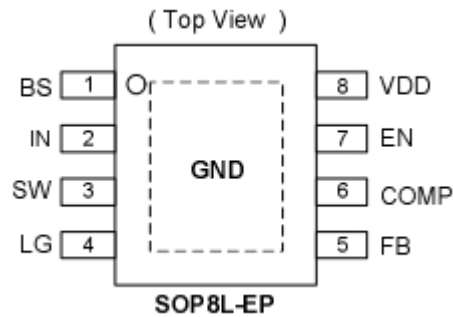

Name	Description
BS	Boot-Strap Pin. Supply high side gate driver. Decouple this pin to LX pin with 0.1uF
IN	Power Input pin. Bypass IN to GND with a suitably large capacitor to eliminate noise on
SW	Power Switching Output. SW is the switching node that supplies power to the output.
LG	Gate drive for external low side N-MOSFET..
PAD	Ground (Connect to GND).
FB	Feedback Input. FB senses the output voltage to regulate that voltage. Drive FB with a
COM	Compensation Node. COMP is used to compensate the regulation control loop. Connect
EN	Enable control. Pull high to turn on. Do not float.
VDD	Internal regulator pin

Ordering/ Marking Information

EC9303NN XX X

└── R : Tape & Reel

MH : SOP 8(Exposed Pad)

Package type	Part Number	Marking	Marking Information
SOP 8L (Exposed Pad)	EC9303NNMHR	MA5604 YYWWT	1. LLLLL : Last five number of lot no. 2. YYWW : Date Code 3. T: Tracking code

Block Diagram

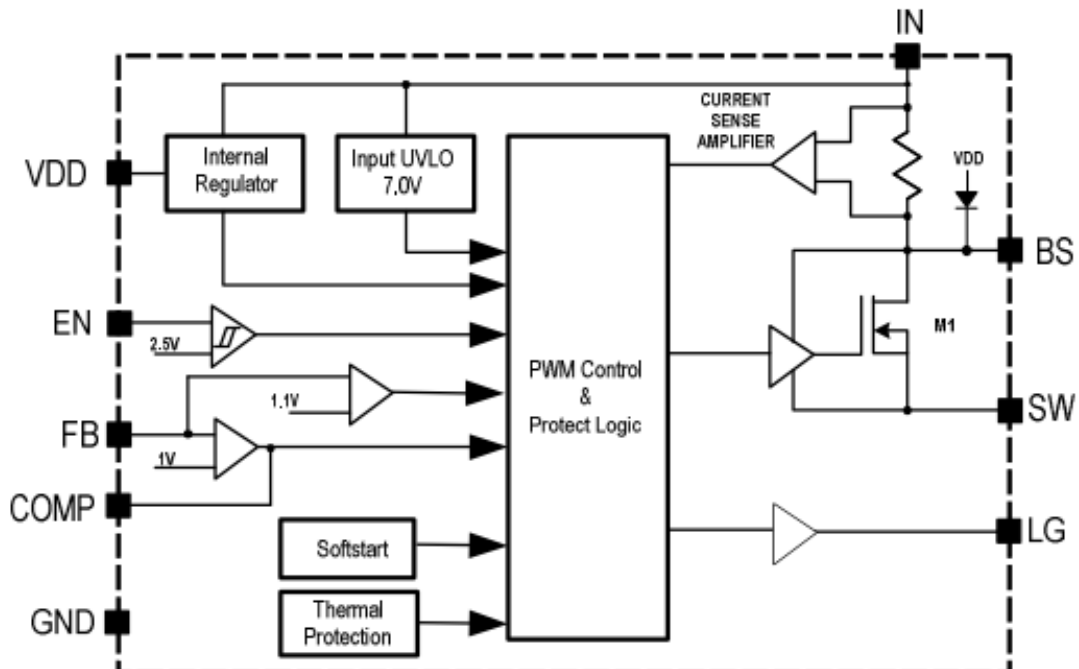

Absolute Maximum Ratings (at T_A=25°C)

Characteristics	Symb	Rating	Unit
Supply Voltage	V _{IN}	-0.3 to +42	V
Switch Node Voltage	V _{SW}	- 0.3 to V _{IN} + 0.3	V
Boost Voltage	V _{BS}	V _{SW} - 0.3 to V _{SW} + 6	V
All Other Pins		-0.3 to +6	V
Lead Temperature		260	°C
Storage Temperature		-65 to +150	°C
Junction Temperature	T _J	150	°C
Output Voltage	V _{OUT}	V _F B to 20	V
Ambient Operating Temperature		-40 to +85	°C
Thermal Resistance from Junction to	θ _{JC}	15	°C/W
Thermal Resistance from Junction to	θ _{JA}	40	°C/W

Note: θ_{JA} is measured with the PCB copper area of approximately 1 in²(Multi-layer). That need connect to exposed pad.

Electrical Characteristics (V_{IN} = 12V, T_A = +25°C, unless otherwise noted.)

Characteristics	Symbol	Conditions	Min	Typ	Max	Units
Input Voltage Range			8	-	38	V
Shutdown Supply Current	ISD	V _{EN} = 0V	-	0.7	1.3	mA
Quiescent Current	ICCQ	V _{EN} = 5.0V; V _F B = 1.05V	-	0.7	1.5	mA
Feedback Voltage	V _F B	8V ≤ V _{IN} ≤ 38V	0.98	1.00	1.02	V
Feedback Overvoltage Threshold	OVP(FB)		-	1.1X	-	V _F B
High-Side Switch On Resistance (Note)	R _{DS(ON)1}		-	80	-	mΩ
High-Side Switch Leakage Current		V _{EN} = 0V, V _{SW} = 0V	-	-	10	μA
High-Side Switch Current Limit		Minimum Duty Cycle	5.1	6.0	-	A
LG Rise Time	TLXR	CLX=1000pF	-	40	-	ns
LG Fall Time	TLXF	CLX=1000pF	-	40	-	ns
LG driver bias supply voltage			-	5	-	V
Oscillation Frequency	FOSC1		-	160	-	KHz
Short Circuit Oscillation Frequency	FOSC2	V _F B = < 0.5V	-	60	-	KHz

Maximum Duty Cycle	D _{MAX}		-	90	-	%
Minimum On Time (Note)	T _{ON(min)}		-	220	-	ns
EN Lockout Threshold Voltage	ENH(LOCK)		-	2.5	-	V
EN Lockout Hysteresis			-	210	-	mV
Input Under Voltage Lockout Threshold	UVLO	V _{IN} Rising	6.5	7.0	7.5	V
Input Under Voltage Lockout Threshold Hysteresis	UVLO-Hys		-	800	-	mV
Input Over Voltage Lockout	OVLO	V _{IN} Rising	-	40	-	V
Input Over Voltage Lockout Threshold	OVLO-Hys		-	5	-	V
Soft-Start Period			-	3	-	ms
Thermal Shutdown	TSD		-	150	-	°C
Thermal Shutdown Hysteresis	TSH		-	30	-	°C

Note: Guaranteed by design.

Function Description

The EC9303 is a synchronous rectified, current-mode, step-down regulator. It regulates input voltages from 8V to 38V down to an output voltage as low as V_{FB}, and supplies up to 5A of load current.

The EC9303 uses current-mode control to regulate the output voltage. The output voltage is measured at FB through a resistive voltage divider and amplified through the internal Transconductance error amplifier. The voltage at the COMP pin is compared to the switch current measured internally to control the output voltage.

The converter uses internal N-Channel MOSFET switches to step-down the input voltage to the regulated output voltage. Since the high side MOSFET requires a gate voltage greater than the input voltage, a boost capacitor connected between SW and BS is needed to drive the high side gate. The boost capacitor is charged from the internal 5V rail when SW is low.

When the EC9303 FB pin exceeds 10% of the nominal regulation voltage of V_{FB}, the over voltage comparator is tripped and the COMP pin is discharged to GND, forcing the high-side switch off.

Application Information

COMPONENT SELECTION

Setting the Output Voltage

The output voltage is set using a resistive voltage divider from the output voltage to FB pin. The voltage divider divides the output voltage down to the feedback voltage by the ratio. Thus the output voltage is:

$$V_{OUT} = V_{FB} \times \frac{R1 + R2}{R2}$$

For example, V_{FB} = 1.00V for a 5.0V output voltage, R₂ is 10kΩ, and R₁ is 40kΩ.

Inductor Selection

The inductor is required to supply constant current to the output load while being driven by the switched input voltage. A larger value inductor will result in less ripple current that will result in lower output ripple voltage. However, the larger value inductor will have a larger physical size, higher series resistance, and/or lower saturation current. A good rule for determining the inductance to use is to allow the peak-to-peak ripple current in the inductor to be approximately 30% of the maximum switch current limit.

VIN	<28V	<35V
Inductor	47uH	33uH

The choice of which style inductor to use mainly depends on the price vs. size requirements and any EMI requirements.

Typical Characteristics

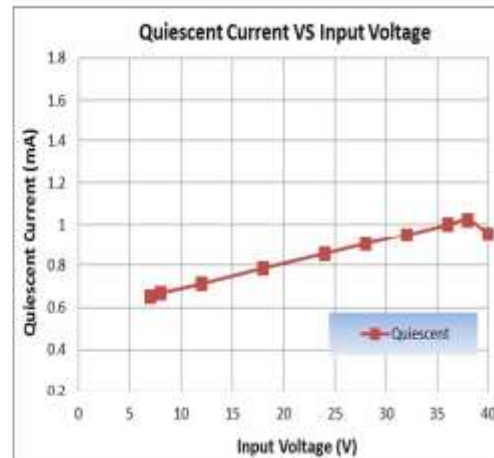
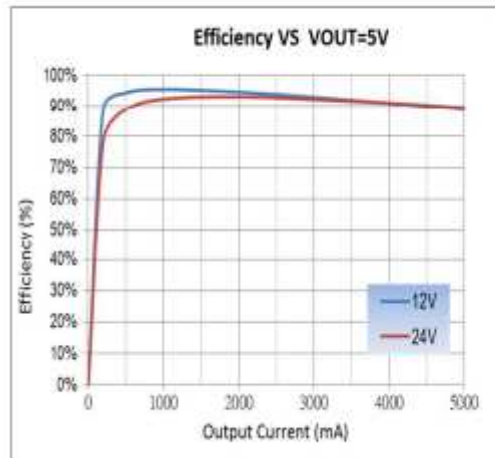

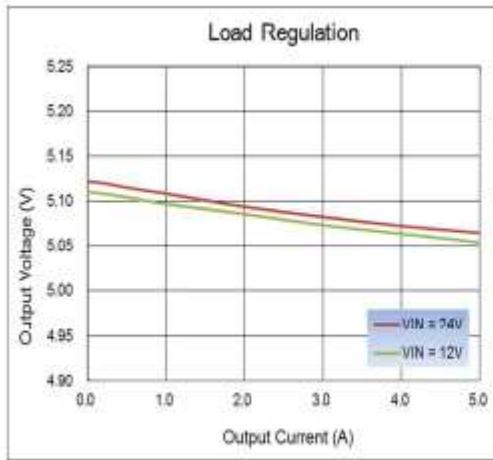

Power On: $V_{IN} = 12V$, $V_{OUT} = 5V$, $I_{LOAD} = 0A$

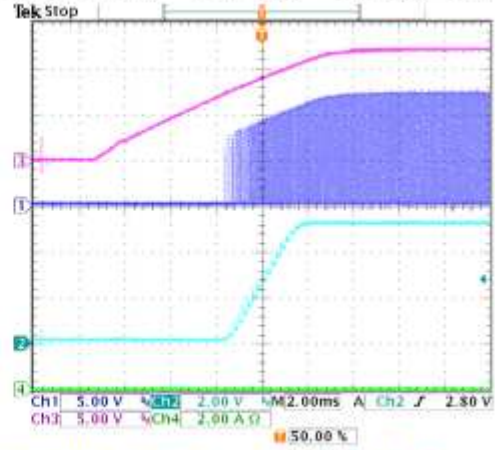

Ch1=SW, Ch2=V_{OUT}, Ch3=V_{IN}, Ch4=I_{OUT}

EN On: $V_{IN} = 12V$, $V_{OUT} = 5V$, $I_{LOAD} = 5A$

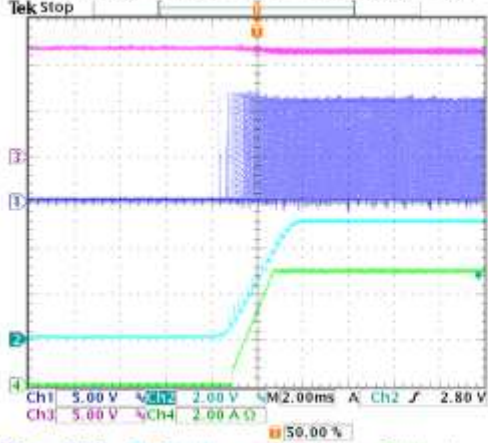

Ch1=SW, Ch2=V_{OUT}, Ch3=V_{IN}, Ch4=I_{OUT}

Cable On: $V_{IN} = 12V$, $V_{OUT} = 5V$, $I_{LOAD} = 5A$

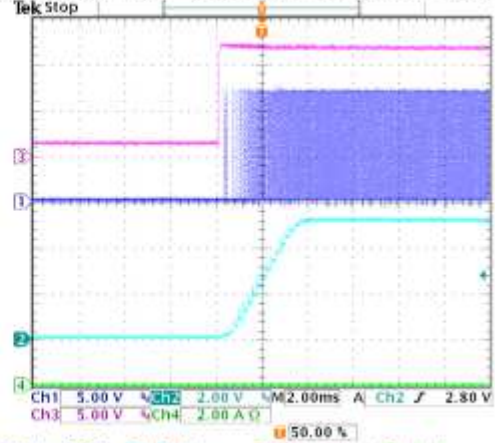

Ch1=SW, Ch2=V_{OUT}, Ch3=V_{IN}, Ch4=I_{OUT}

Package Outlines

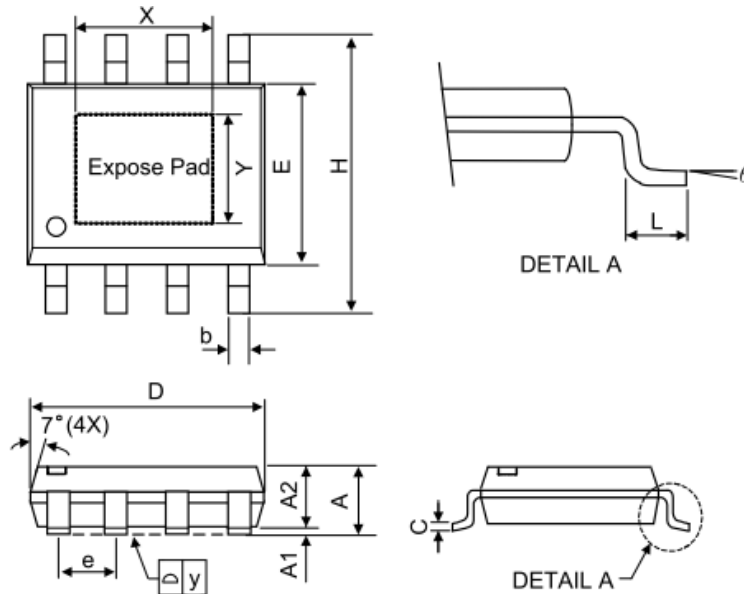

Symbol	Dimensions in Millimeters			Dimensions in Inches		
	Min.	Nom.	Max.	Min.	Nom.	Max.
A	-	-	1.75	-	-	0.069
A1	0	-	0.15	0	-	0.06
A2	1.25	-	-	0.049	-	-
C	0.1	0.2	0.25	0.0075	0.008	0.01
D	4.7	4.9	5.1	0.185	0.193	0.2
E	3.7	3.9	4.1	0.146	0.154	0.161
H	5.8	6	6.2	0.228	0.236	0.244
L	0.4	-	1.27	0.015	-	0.05
b	0.31	0.41	0.51	0.012	0.016	0.02
e	1.27 BSC			0.050 BSC		
y	-	-	0.1	-	-	0.004
X	-	2.34	3.33	-	0.092	0.131
Y	-	2.34	2.54	-	0.092	0.10
θ	0°	-	8°	0°	-	8°

Mold flash shall not exceed 0.25mm per side
JEDEC outline: MS-012 BA