

### General Description

EC3268A is a Synchronous Buck Circuit with two current sense pins suitable for many multi- output applications. It is designed to allow for operating a wide supply voltage range from 4.7V to 30V. This IC can operate in both Constant Current (CC) and Constant Voltage (CV) modes. EC3268A operates as a Buck Circuit providing a wide range of outputs at Constant Voltage (CV) from 4.7V to 30V and the output current as high as 8A or above. It has a Constant Current (CC) mode so that output current can be set externally and at an accuracy of  $\pm 4\%$ . The current mode control and external compensation makes feedback control have good line and load regulation with flexible external design.

### Features

- ◆ Vin: 4.2V to 30V
- ◆ Vout: 3V to 28V; typical at 5V
- ◆ Low Dropout Operation: Maximum Duty Cycle at 99.5%
- ◆ Precision CC/CV Mode Control
- ◆ Burst/PFM Mode for Increased Light Load Efficiency
- ◆ 2 outputs independent Constant Current setting
- ◆ Hiccup mode when output voltage below 50% normal output voltage
- ◆ Protection:
  - NMOS peak current limit: accuracy :  $\sim 20\%$
  - Output short protection: reduce input current to less than 20mA (RMS)
  - Output FB OVP (125% VFB), only turn off High side MOS.
  - Temperature shutdown (OTP)
- ◆ Adjustable Output Cable Resistance Compensation
- ◆ Switching Frequency: 125k+25k
- ◆ Integrated Power MOSFET
- ◆ QFN32L Package

### Applications

- ◆ USB Power Supplies with PD
- ◆ High- Brightness Lighting
- ◆ General- Purpose DC/DC Application

### Pin Configurations

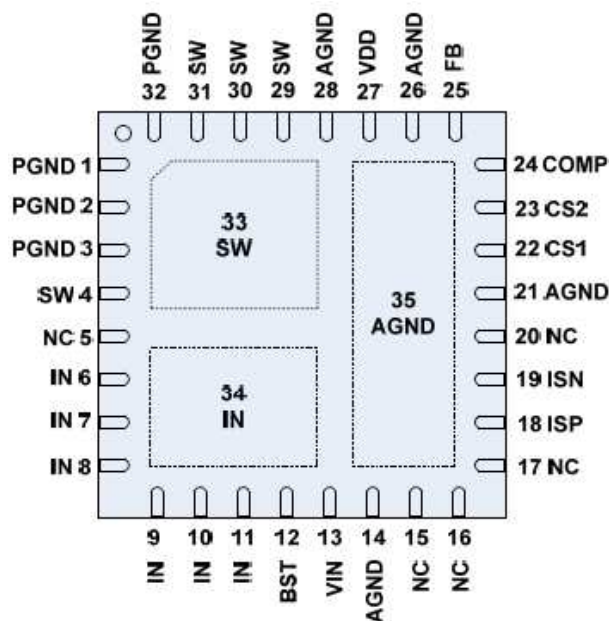

Figure1 Pin Configuration of EC3268A (Top View)



### Pin Description

Pin Number	Pin Name	Description
1,2,3, 32	PGND	Power Ground pin.
4, 29,30,31,33	SW	Inductor terminal.
5,15,16,17,20	NC	Not connected
6,7,8,9,10,11,34	IN	Power input
12	BST	Internal High Side Driver Power Bias which is typically 5V above Vin. A typical 0.1uF capacitor is used connecting between BST and SW pins.
13	VIN	Supply input
14,21,26,28,35	AGND	Signal Ground for The IC.
18	ISP	Input Current Sense.
19	ISN	Input Current Sense.
22	CS1	Current sense of the 1st output.
23	CS2	Current sense of the 2nd output.
24	COMP	Error Amplifier Output. The Converter stability compensation network is placed.
25	FB	Feedback input with reference to 1.20V. It can set output voltage.
27	VDD	Internal 5v power supply, a 1uF (or more) capacitor is connected between this pin and GND.

### Function Block

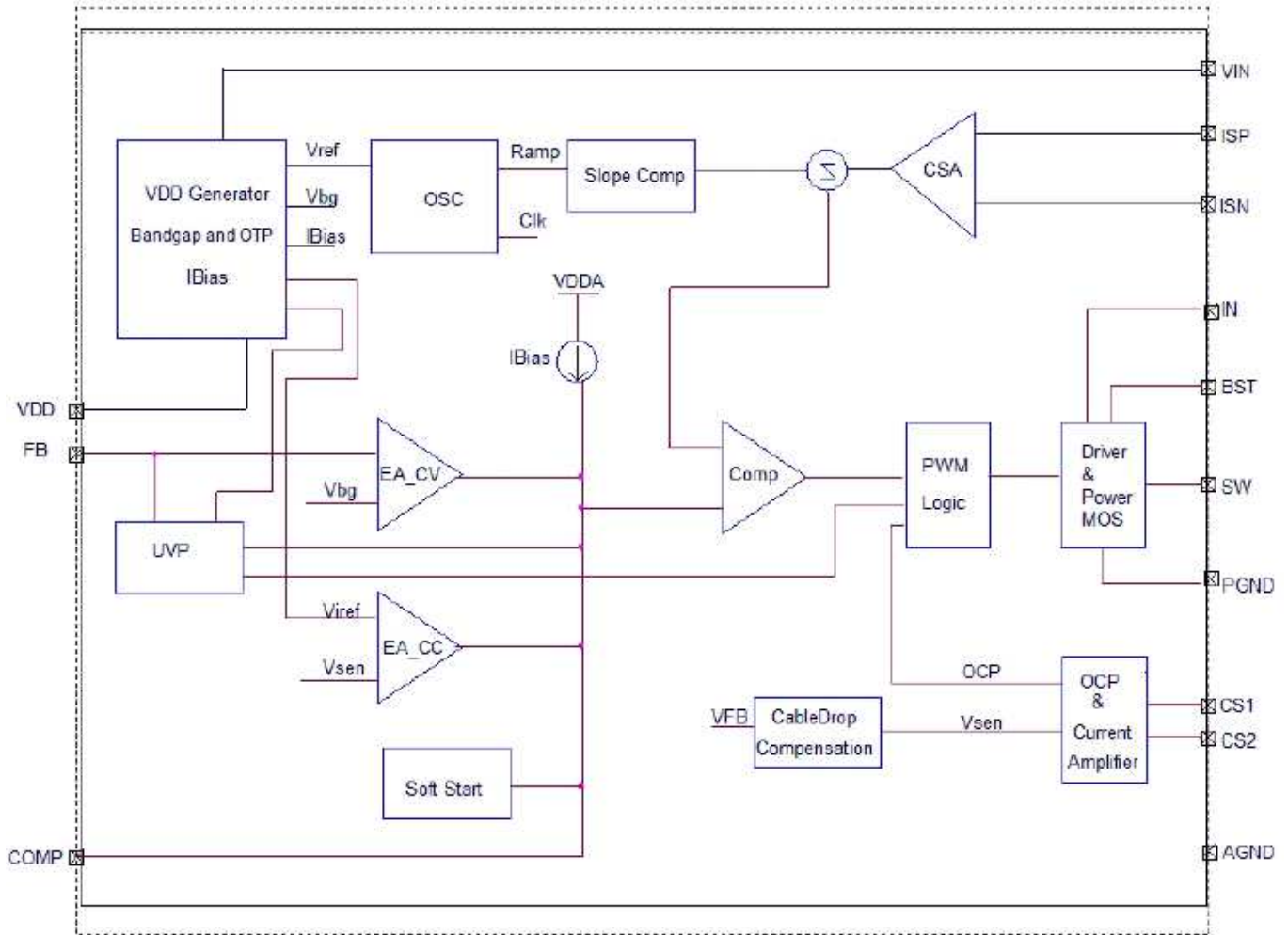

Figure 2 Function Block Diagram of EC3268A

### Absolute Maximum Ratings

Symbol	Parameter	Rating	Unit
VIN	Supply Input Voltage	-0.3 to +30	V
	ISP,ISN to VIN	-0.3 to +0.3	V
	BST to SW	-0.3 to +6	V
	SW to GND	-0.3 to VIN+0.6	V
	BST to GND	VSW-0.3 to VSW+6	V
	VDD,VFB,ISET,COMP,CS1- 2 to GND	-0.3 to +6	V
ESD	HBM (Human Body Mode)	2K	V
$\theta_{JA}$	Thermal Resistance from Junction to ambient	40	°C/W

**Recommended Operating Conditions**

Symbol	Parameter	Rating			Unit
		Min.	Typ.	Max.	
V <sub>IN</sub>	Supply Voltage	4.7*	-	30	V
V <sub>OUT</sub>	Output voltage range	3	-	28	V
I <sub>OUT</sub>	Output current range	-	-	8	A
T <sub>OP</sub>	Operating Temperature	- 40	-	85	°C
T <sub>STG</sub>	Storage Temperature Range	- 65	-	150	°C
T <sub>J</sub>	Junction Temperature	- 40	-	150	°C
T <sub>SDR</sub>	Maximum Lead Soldering Temperature, 10 Seconds	260			°C

Note: \* when supply voltage is around 5V, output load current should be less than 8A.

**Electrical Characteristics**

V<sub>IN</sub>=12V, T<sub>A</sub>=25°C (unless otherwise specified)

Symbol	Characteristic	Test conditions	Min	Typ	Max	Unit
V <sub>IN</sub>	Supply Voltage		4.2	-	30	V
I <sub>IN</sub>	Supply Input Current	V <sub>out</sub> =5V, No load	1	1.7	3.5	mA
<b>VIN UVLO</b>						
V <sub>UP</sub>	V <sub>IN</sub> UVLO Turn ON	V <sub>IN</sub> Rising	3.5	4.0	4.5	V
V <sub>HYS</sub>	V <sub>IN</sub> UVLO Hysteresis	V <sub>IN</sub> Falling	-	0.6	-	V
<b>Feedback voltage</b>						
V <sub>FB</sub>	Feedback voltage		1.176	1.20	1.224	V
	Tolerance		- 2	-	2	%
<b>Soft Start</b>						
	Soft Start time		-	6	-	ms
<b>Oscillator</b>						
F <sub>SW</sub>	Switch frequency		100	125	150	KHz
T <sub>ON</sub>	Minimum On- Time		-	100	-	ns
D	Duty cycle		-	-	99.5	%
<b>Current sense</b>						
V <sub>THCC</sub>	CC threshold		65	68	71	mV
I <sub>FB</sub>	Cable compensation Current	CS1- 2=68mv	-	2	-	uA
<b>POWER MOSFET</b>						
	High Side MOSFET Resistance		-	10	-	mΩ
	Low Side MOSFET Resistance		-	10	-	mΩ
<b>Thermal Shutdown(OTP)</b>						
T <sub>SD</sub>	Temperature Rising		-	150	-	°C
T <sub>HYS</sub>	OTP Hysteresis		-	20	-	°C

### Typical Application Circuit

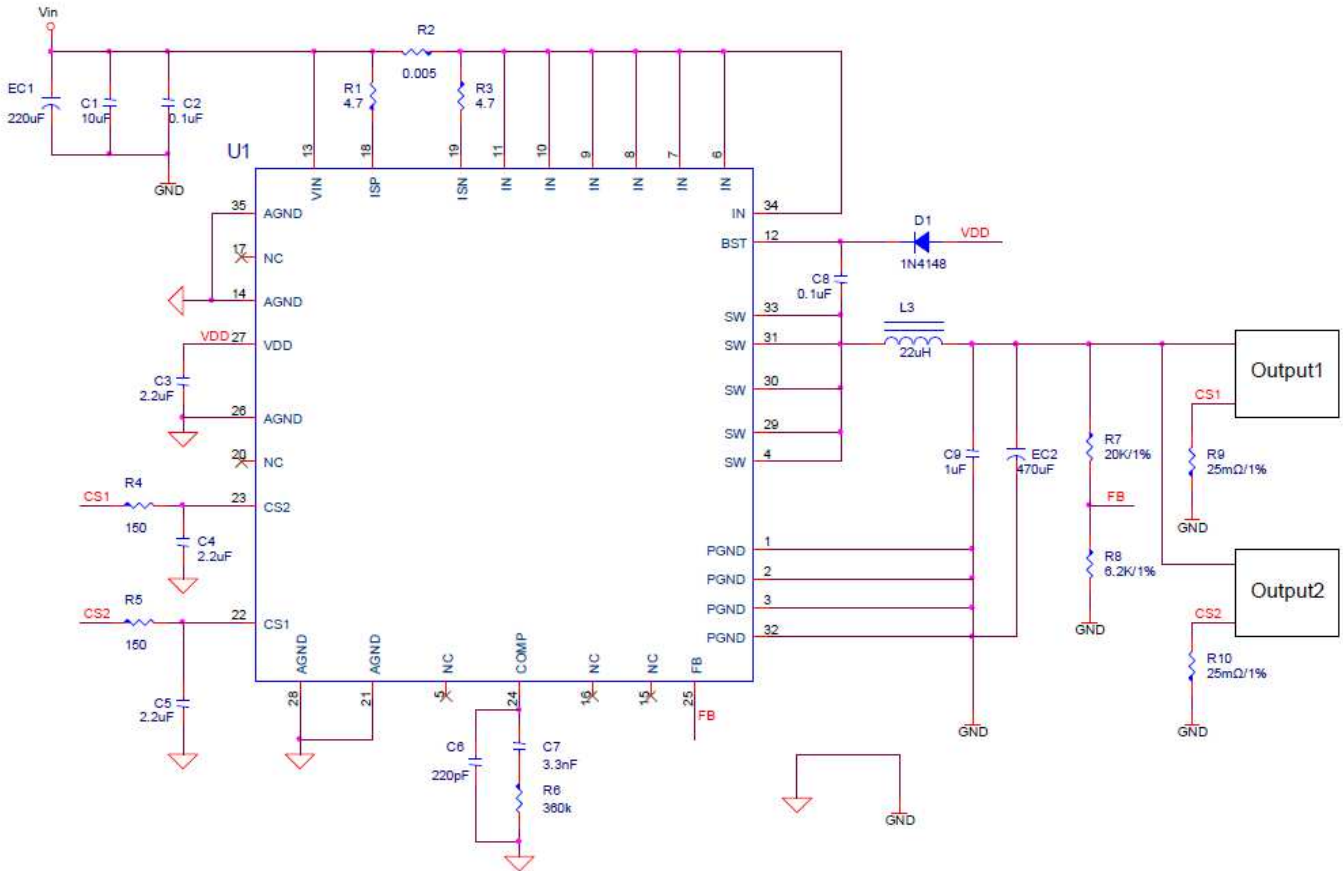
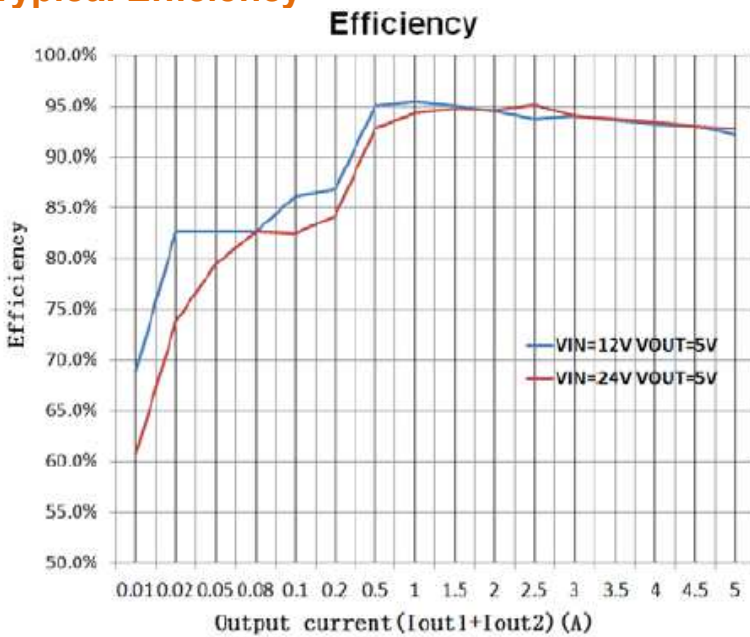

Figure 3 2-outputs with CC(CS1 and CS2)

### Typical Efficiency



### Typical Operating Characteristics

(12vin 5vout, load: 1Ω resistance single output, CS to GND resistance: 10mΩ)

1. Start :

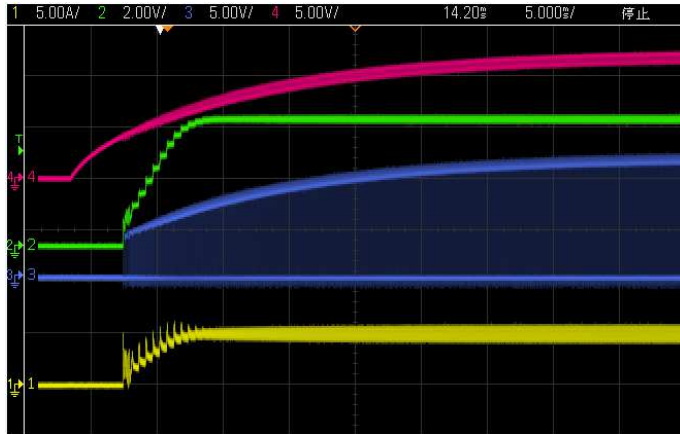

Ch1 IL CH2 VOUT CH3 SW CH4 VIN

2. SCP Entry:

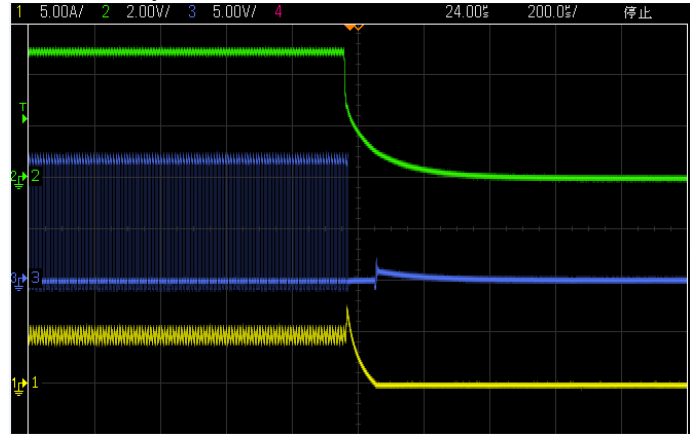

Ch1 IL CH2 VOUT CH3 SW

3.SCP Steady state:



Ch1 IL CH2 VOUT CH3 SW

4. SCP Recovery:

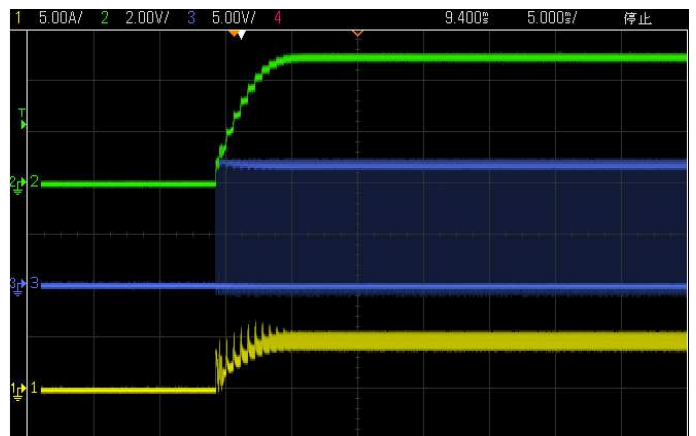

Ch1 IL CH2 VOUT CH3 SW

### Function Description

EC3268A operates in a peak-current-mode control to regulate the output voltage. It integrates a monolithic synchronous, rectified, step-down, switch-mode converter with internal power MOSFETs. It offers a compact solution to achieve 8A of continuous output current over a wide input-supply range with excellent load and line regulation. The internal clock initiates the PWM cycle, which turns on the integrated high side power MOSFET. The high-side MOSFET remains on until its current reaches the value set by the COMP voltage. When the power switch is off, it remains off until the next clock cycle begins.

#### CC/CV Mode Control

EC3268A provides CC/CV function. The Constant output Current control Mode and Constant output Voltage control Mode.

#### Output Voltage Setting

VFB is the feedback pin and connected to the non-inverting of error amplifier input. The output voltage is adjustable from 1.2V to 28V with a resistor-divider connected with VFB GND and converter's output. Using 1% or better resistors for the resistor-divider is recommended. The output voltage is determined by the equation:  
 $V_{OUT} = V_{FB} * (1 + R1/R2) = 1.2V * (1 + R1/R2)$

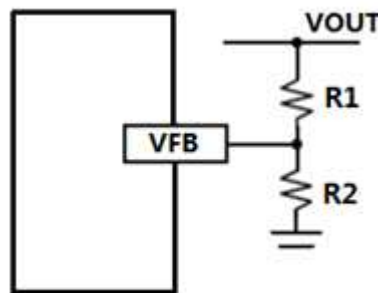

R1 can program the cable compensation.

#### FB OVP

If  $FB > 125% * 1.2V$ , the controller turn off the high side PWR MOS immediately.

#### FB UVP

For EC3268A, Hiccup Mode of Under Voltage Protection (UVP) is provided. If cc mode is triggered or over current protection(OCP)/short current protection(SCP) occur, the output voltage will be pulled down quickly. When  $FB < 50% * V_{FB}$ , the controller will enter hiccup mode by disabling the converter and restarts soft-start after a predefined interval about 4s until the under voltage condition is removed.

#### FB Fast response

If  $FB > 105% * 1.2V$  or  $FB < 95%$ , the controller turn off or turn on the high side PWR MOS immediately. This design reduce the overshoot and undershoot when load change suddenly

#### Soft start

The controller integrates a soft start circuit. The soft time is 6ms roughly.

#### Constant Current setting

The voltage of CS1 or CS2 pins reaches the voltage on  $V_{THCC}(68mV)$ , the system will enter CC mode, the CC current can be calculated by followings:

$$I_{CC} = V_{THCC} / (R_{CS1} \text{ or } R_{CS2})$$

Here  $R_{CS1}$ ,  $R_{CS2}$  are the sense resistors between CS1, CS2 and GND.

#### Output Cable Resistance Compensation

To compensate for resistive voltage drop across the charger's output cable, the controller integrates a simple, user-programmable cable voltage drop compensation using the impedance at the FB pin. By choosing different R1, we can get different cable voltage drop compensation values.

$$V_{cdc} = (V_{cs1} \text{ or } V_{cs2}) * R1 / 34000 \quad (V_{cs1} \text{ or } V_{cs2} > 8mv)$$

#### Over Temperature Protection (OTP)

EC3268A provides over temperature protection (OTP). The OTP will shut down the converter when junction temperature exceeds 150°C. Once the junction temperature cools down by approximately 30°C, the controller will resume.



### Output Inductor Selection

The inductor value (L) determines the inductor ripple current,  $I_{RIPPLE}$  and affects the load transient response. Higher inductor value reduces the inductor's ripple current and induces lower output ripple voltage. The ripple current and ripple voltage can be approximated by:

$$L = V_{OUT} * (V_{IN} - V_{OUT}) / F_{SW} * I_{RIPPLE} * V_{IN}$$

Where

$F_{SW}$  : the switching frequency of the regulator;

$V_{IN}/V_{OUT}$  : input voltage/output voltage;

$I_{RIPPLE}$  is the inductor ripple current and  $I_{RIPPLE} = (0.3-0.5)I_{OUT}$

### Input Capacitor

A low ESR capacitor is highly recommended. Since large current flows in and out of this capacitor during switching, its ESR also affects efficiency. The input capacitance should be higher than  $100\mu F$ . The best choice is the ceramic type, however, low ESR tantalum or electrolytic types may also be used. The input capacitor should be placed close to the  $V_{IN}$  and GND pins of the IC, with the shortest traces possible. In the case of tantalum or electrolytic types, they can be further away if a small parallel  $1\mu F$  ceramic capacitor is placed right next to the IC.

### Output Capacitor

The system requires the output capacitor to maintain the dc output voltage. The characteristics of the output capacitor affect the stability of the regulatory system. A low ESR electrolytic capacitor is recommended for a low output ripple and good control loop stability. For general applications, a  $1\mu F$  ceramic capacitor and a  $330\mu F$  (or more) polymer/electrolytic capacitor are recommended.

## Package Information

QFN5x5- 32L Package Outline Dimensions

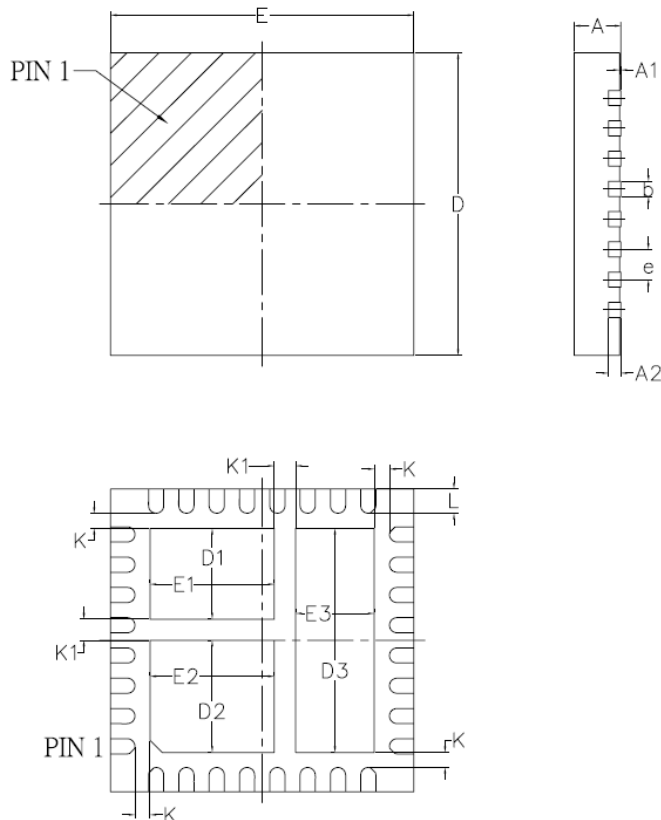

SYMBOL		A	A1	A2	b	D	D1	D2	D3	E	E1	E2	E3	e	L	K	K1
Milli meter	MIN	0.70	0.05	0.203	0.20	4.95	1.40	1.75	3.60	4.95	1.95	1.95	1.20	0.50	0.30	0.25	0.35
	MAX	0.80	MAX	REF	0.30	5.05	1.60	1.95	3.80	5.05	2.15	2.15	1.40	BSC	0.50	BSC	BSC
Inch	MIN	0.0276	0.0020	0.0080	0.0079	0.1949	0.0551	0.0689	0.1417	0.1949	0.0768	0.0768	0.0472	0.0197	0.0118	0.0098	0.0138
	MAX	0.0315	MAX	REF	0.0118	0.1988	0.0630	0.0768	0.1496	0.1988	0.0846	0.0846	0.0551	BSC	0.0197	BSC	BSC